

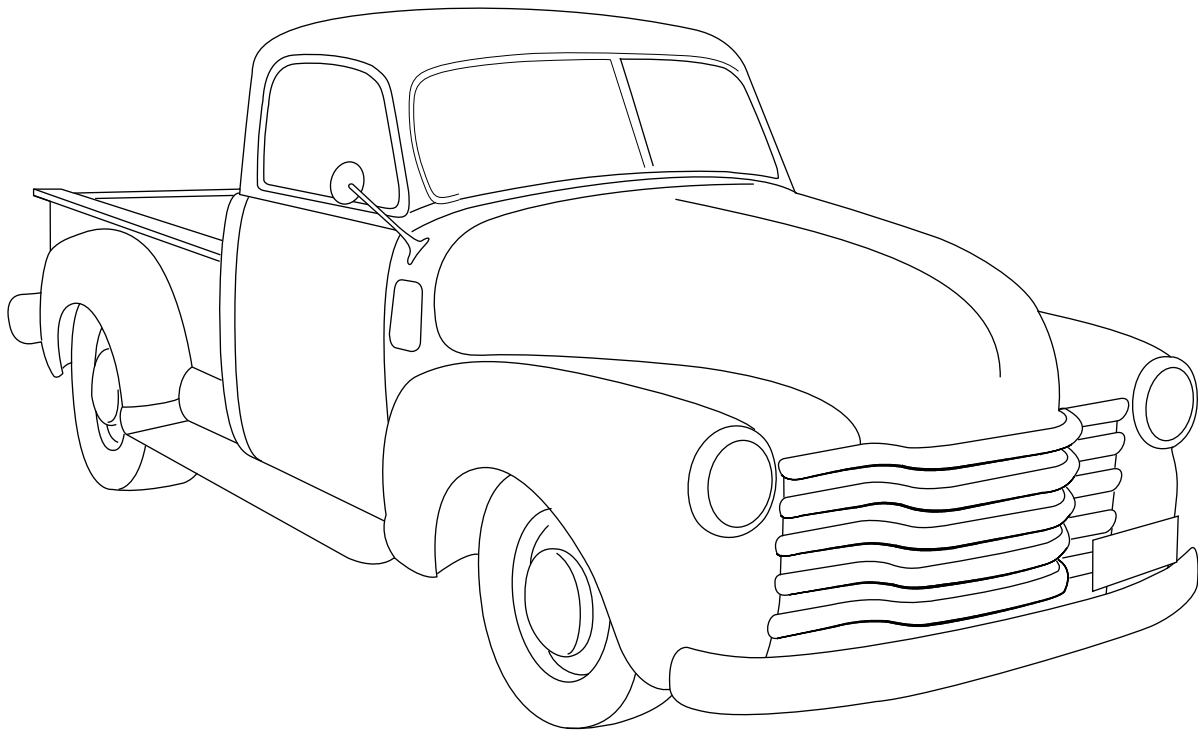

an ISO 9001:2015 Registered Company

1950-53 Chevrolet Pickup

**Evaporator Kit
(754562)**



18865 Goll St. San Antonio, TX 78266
Phone: 800-862-6658
Sales: sales@vintageair.com
Tech Support: tech@vintageair.com
www.vintageair.com



www.vintageair.com

Table of Contents

Cover.....	1
Table of Contents.....	2
Packing List/Parts Disclaimer.....	3
Information Page.....	4
Wiring Notice.....	5
Engine & Passenger Compartment Disassembly.....	6
Condenser Assembly and Installation, Compressor and Brackets, Pulleys, Defrost Duct Installation.....	7
Evaporator Assembly Preparation.....	8
Firewall Bracket and Heater Hose Fitting Installation, Lubricating O-rings.....	9
A/C & Heater Hose Installation.....	10
A/C & Heater Hose Installation (Cont.), Firewall Cover Installation.....	11
Evaporator Installation.....	12
Evaporator Installation (Cont.).....	13
Rotary Pot Installation.....	14
Control Panel/Louver Bezel Assembly Installation.....	15
Evaporator Installation (Final).....	16
Driver Side Under Dash Louver Installation, Heater Control Valve Installation.....	17
A/C & Heater Hose Installation, V-8 Engines (Final).....	18
A/C & Heater Hose Installation, 6-Cylinder Engines (Final).....	19
Control Panel & Duct Hose Routing.....	20
Wiring.....	21
Glove Box Installation (1950-52 Vehicles) Glove Box Installation (1953 Vehicles).....	22
Drain Hose Installation, Final Steps.....	23
Wiring Diagram.....	24
Gen IV Wiring Connection Instruction.....	25
Operation of Controls.....	26
Troubleshooting Guide.....	27
Troubleshooting Guide (Cont.).....	28
Packing List.....	29



www.vintageair.com

Packing List: Evaporator Kit (754562)

No.	Qty.	Part No.	Description
1.	1	744004-VUE	Gen IV Evaporator Sub Case, 4-Vent
2.	1	799003	Accessory Kit

**** Before beginning installation, open all packages and check contents of shipment. Please report any shortages directly to Vintage Air within 15 days. After 15 days, Vintage Air will not be responsible for missing or damaged items.**

1

**Gen IV Evaporator
Sub Case 4-Vent
744004-VUE**

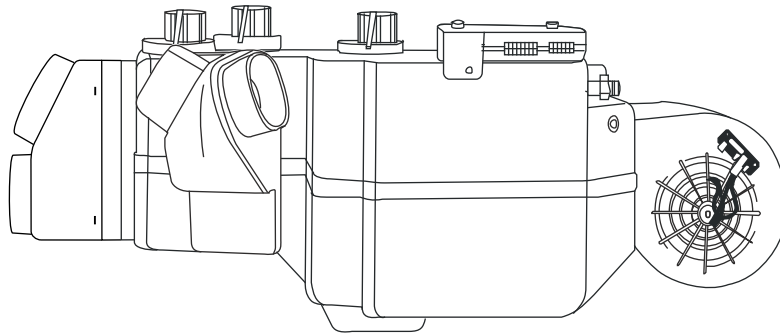

2

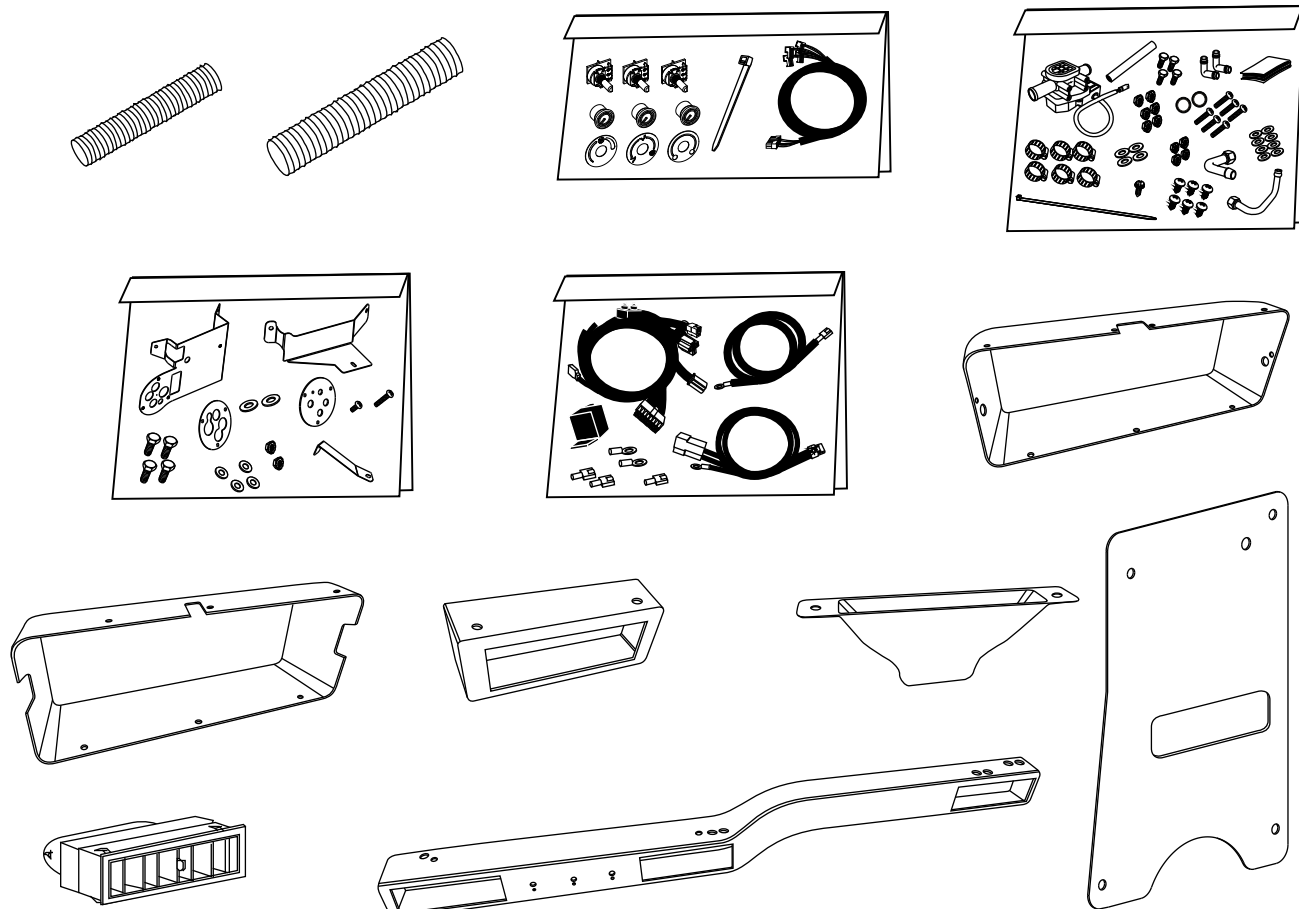

**Accessory Kit
799003**

NOTE: Images may not depict actual parts and quantities. Refer to packing list for actual parts and quantities.



www.vintageair.com

Important Notice—Please Read

For Maximum System Performance, Vintage Air Recommends the Following:

NOTE: Vintage Air systems are designed to operate with R134a refrigerant only. Use of any other refrigerant could damage your A/C system and/or vehicle, and possibly cause a fire, in addition to potentially voiding the warranties of the A/C system and its components.

Refrigerant Capacities:

Vintage Air System: 1.8 lbs. (1 lb., 12 oz.) of R134a, charged by weight with a quality charging station or scale. **NOTE:** Use of the proper type and amount of refrigerant is critical to system operation and performance.

Other Systems: Consult manufacturer's guidelines.

Lubricant Capacities:

New Vintage Air-supplied Sanden Compressor: No additional oil needed (Compressor is shipped with proper oil charge).

All Other Compressors: Consult manufacturer (Some compressors are shipped dry and will need oil added).

Safety Switches

Your Vintage Air system is equipped with a binary pressure safety switch. A binary switch disengages the compressor clutch in cases of extreme low pressure conditions (Refrigerant Loss) or excessively high head pressure (406 PSI) to prevent compressor damage or hose rupture. A trinary switch combines Hi/Lo pressure protection with an electric fan operation signal at 254 PSI, and should be substituted for use with electric fans. Compressor safety switches are extremely important since an A/C system relies on refrigerant to circulate lubricant.

Service Info:

Protect Your Investment: Prior to assembly, it is critical that the compressor, evaporator, A/C hoses and fittings, hardlines, condenser and receiver/drier remained capped. Removing caps prior to assembly will allow moisture, insects and debris into the components, possibly leading to reduced performance and/or premature failure of your A/C system. This is especially important with the receiver/drier.

Additionally, when caps are removed for assembly, **BE CAREFUL!** Some components are shipped under pressure with dry nitrogen.

Evacuate the System for 35-45 Minutes: Ensure that system components (Drier, compressor, evaporator and condenser) are at a temperature of at least 85° F. On a cool day, the components can be heated with a heat gun **or** by running the engine with the heater on before evacuating. Leak check and charge to specifications.

Bolts Passing Through Cowl and/or Firewall:

To ensure a watertight seal between the passenger compartment and the vehicle exterior, for all bolts passing through the cowl and/or firewall, Vintage Air recommends coating the threads with silicone prior to installation.

Heater Hose (Not Included With This Kit):

Heater hose may be purchased from Vintage Air (Part# 31800-VUD) or your local parts retailer. Routing and required length will vary based on installer preference.



www.vintageair.com

Important Wiring Notice—Please Read

Some Vehicles May Have Had Some or All of Their Radio Interference Capacitors Removed. There Should Be a Capacitor Found At Each of the Following Locations:

- 1. On the positive terminal of the ignition coil.**
- 2. If there is a generator, on the armature terminal of the generator.**
- 3. If there is a generator, on the battery terminal of the voltage regulator.**

Most alternators have a capacitor installed internally to eliminate what is called “whining” as the engine is revved. If whining is heard in the radio, or just to be extra cautious, a radio interference capacitor can be added to the battery terminal of the alternator.

It is also important that the battery lead is in good shape and that the ground leads are not compromised. There should be a heavy ground from the battery to the engine block, and additional grounds to the body and chassis.

If these precautions are not observed, it is possible for voltage spikes to be present on the battery leads. These spikes come from ignition systems, charging systems, and from switching some of the vehicle’s other systems on and off. Modern computer-operated equipment can be sensitive to voltage spikes on the power leads, which can cause unexpected resets, strange behavior, and/or permanent damage.

Vintage Air strives to harden our products against these types of electrical noise, but there is a point where a vehicle’s electrical system can be degraded so much that nothing can help.

Radio interference capacitors should be available at most auto and truck parts suppliers. They typically are cylindrical in shape, a little over an inch long, a little over a half inch in diameter, and they have a single lead coming from one end of the cylinder with a terminal on the end of the wire, as well as a mounting clip which is screwed into a good ground on the vehicle. The specific value of the capacitance is not too significant in comparison to ignition capacitors that are matched with the coil to reduce pitting of the points.

- Care must be taken, when installing the compressor lead, not to short it to ground. The compressor lead must not be connected to a condenser fan or to any other auxiliary device. Shorting to ground or connecting to a condenser fan or any other auxiliary device may damage wiring, the compressor relay, and/or cause a malfunction.
- When installing ground leads on Gen IV systems, the blower control ground and ECU ground must be connected directly to the negative battery post.
- For proper system operation, the heater control valve must be connected to the ECU.



www.vintageair.com

Engine & Passenger Compartment Disassembly

NOTE: Before starting the installation, check the function of the vehicle (horn, lights, etc.) for proper operation, and study the instructions, illustrations, & diagrams.

Perform the Following:

1. Disconnect battery. Ensure that the cable remains disconnected throughout the entire installation process.
NOTE: Battery is located under passenger floorboard.
2. Drain radiator.
3. Remove OEM heater hoses (discard).
4. Remove OEM heater/blower assembly if installed (discard) (See Photo 1, below).
5. Remove OEM heater wiring (discard).
6. Remove glove box door (retain).
7. Remove glove box (discard, but retain OEM screws).
8. Disconnect all wires and cables from OEM control panel (discard).
9. Disconnect all wires and cables from OEM heater control knobs (discard).
10. Remove OEM defrost ducts (discard).
11. Remove the defrost vent garnish/cover (retain) (See Photo 2, below).
12. Remove the round cover from the firewall (See Photo 3, below).

OEM Heater Assembly



Photo 1

Defrost Vent Garnish/Cover



Photo 2

Firewall Cover

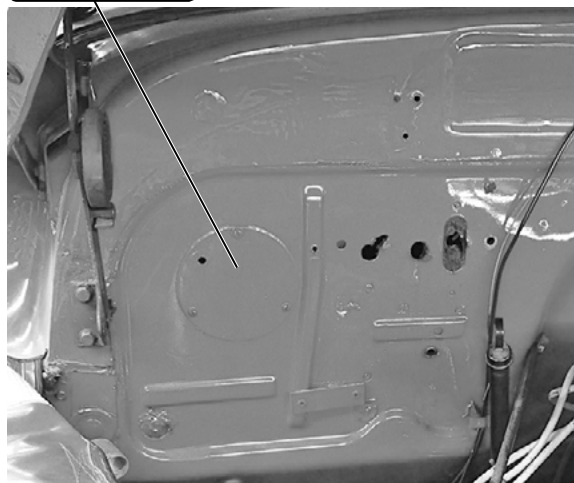

Photo 3



www.vintageair.com

Condenser Assembly and Installation

1. Refer to separate instructions included with the condenser kit to install the condenser.
2. Binary switch installation (Refer to condenser instructions).

Compressor and Brackets

1. Refer to separate instructions included with the bracket kit to install the compressor bracket.

Pulleys

1. In most instances, the belt lengths will remain the same.

Defrost Duct Installation

1. Using a #6 x 3/8" pan head screw, attach 18 inches of 2" duct hose to the passenger side defrost duct (See Photo 1, below). Attach the remainder of the duct hose to the driver side defrost duct.
2. Install the passenger and driver side defrost ducts into the dash using (4) #6 x 3/8" sheet metal screws, (2) screws for each duct (See Photo 2, below). Direct the passenger side defrost duct away from firewall, and toward the wiper arm. Direct the driver side duct toward the firewall, and away from wiper arm (See Photos 3 & 4, below).

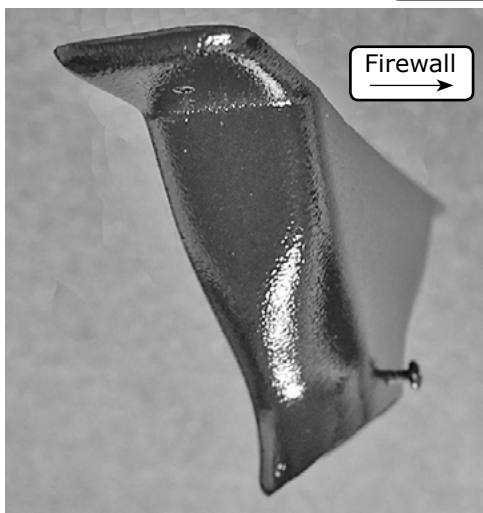
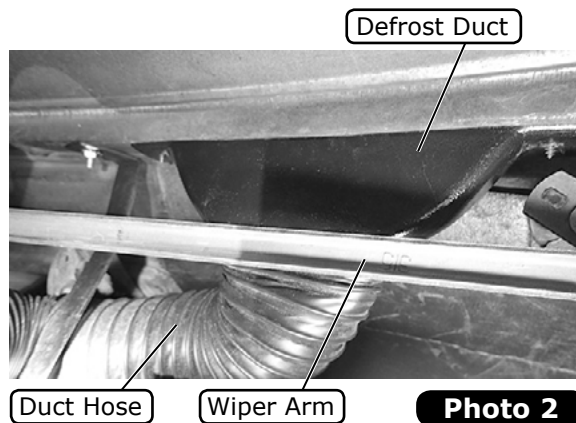
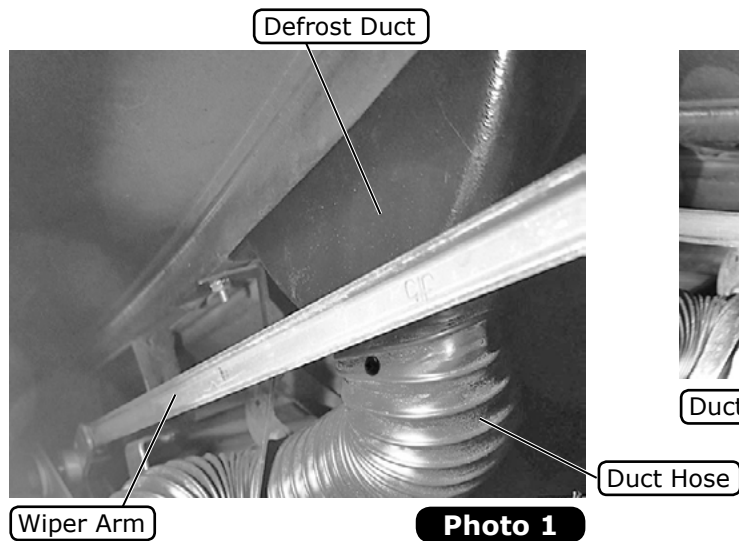

Driver Side

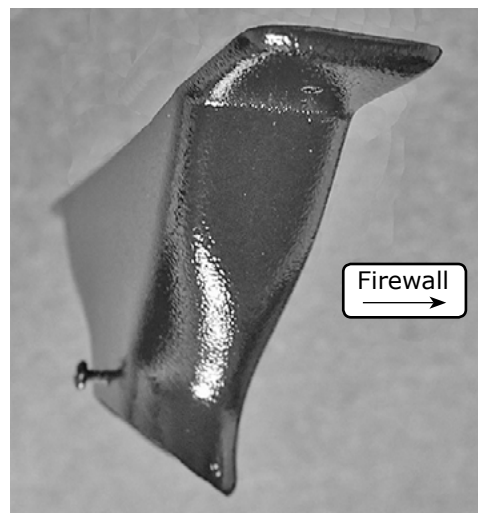

Passenger Side



www.vintageair.com

Evaporator Assembly Preparation

NOTE: Preparation of the evaporator assembly will be done on a workbench. Locate the evaporator firewall bracket, hoses, heater hose fittings, O-rings, bolts, washers, lubricant, tie wrap, and press tape. As much as possible, always keep caps on hoses, hardlines and evaporator coils. The top of the evaporator unit is the side with the control module.

1. Place the evaporator unit on a workbench. **NOTE:** To avoid scratching the unit, place it on a small piece of carpet or similar surface, as you will be turning over the unit over many times while preparing for the installation (See Photo 1, below).
2. Locate the #6 A/C hose with 45° and straight female fittings. Temporarily (without an O-ring) connect the 45° fitting on the hose to the condenser core hardline (previously installed with the condenser kit) directing the 45° fitting down to the depression on the inner fender inside the engine compartment as shown in Photo 2, below. Next, direct the straight end of the hose to the hole on the firewall. Using a permanent marker, make a mark on the side of the fitting that faces the front of the truck (See Photos 3 & 4, below). **NOTE:** This hose will be permanently connected to the evaporator while on the bench. Therefore, to prevent twisting of the hose, it is necessary to orient the 45° fitting by using the condenser core hardline as a reference.

Evaporator Unit

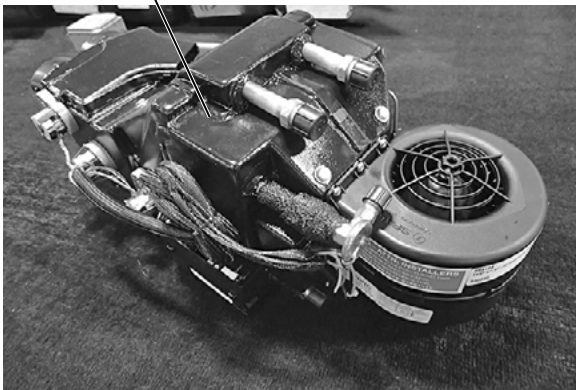
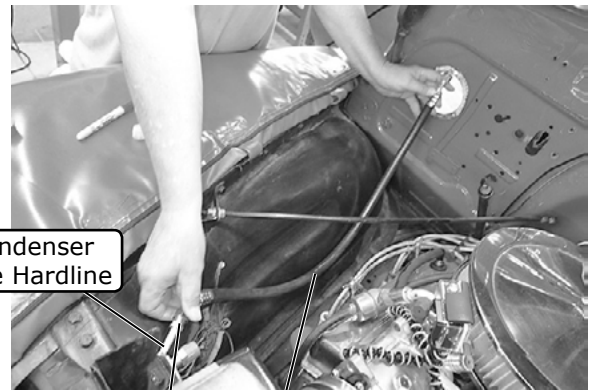

Photo 1



Condenser Core Hardline

45° Fitting

#6 A/C Hose

Photo 2

Mark Fitting



Photo 3

Mark Fitting



Photo 4



www.vintageair.com

Firewall Bracket and Heater Hose Fitting Installation

1. Using a properly lubricated O-ring, install the lower heater hose fitting (from intake) onto the evaporator (See Photo 1 & Figure 1, below).
2. Install the firewall bracket onto the evaporator using (3) 1/4-20 x 1/2" bolts (supplied on evaporator unit) (See Photos 2, 3, & 4, below). **NOTE: When heater hoses are installed, they will pass through the firewall bracket. Therefore, ensure that the heater hose fittings are centered in the 1.100" holes on the bracket (See Photo 2, below).**
3. Install the upper heater hose fitting (to water pump) onto the evaporator with a properly lubricated O-ring (See Photo 3 & Figure 1, below).

Lower Heater Hose Fitting

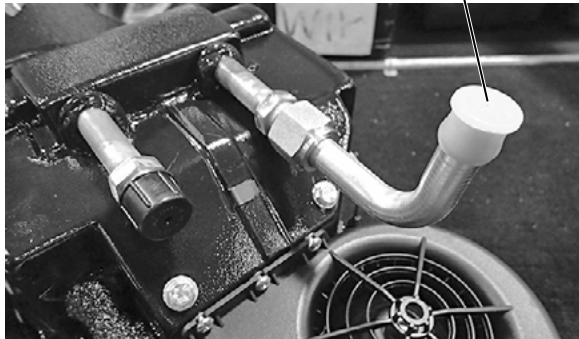
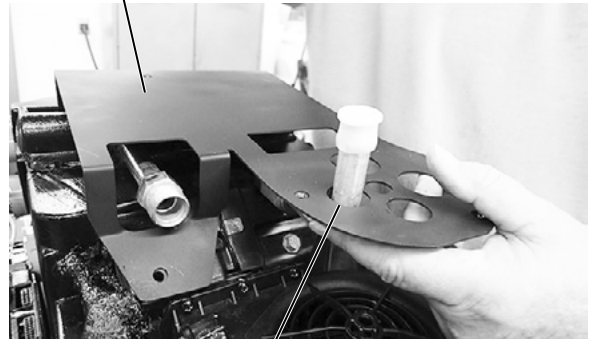

Photo 1

Firewall Bracket



Center Hose Fitting in Hole

Photo 2

Upper Heater Hose Fitting

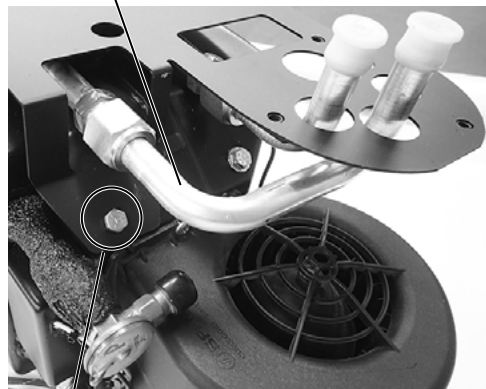

1/4-20 x 1/2" Bolt

Photo 3

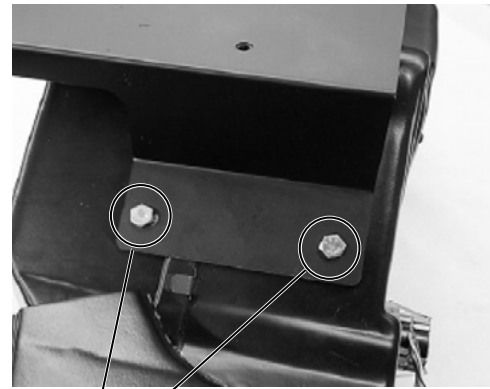

(2) 1/4-20 x 1/2" Bolts

Photo 4

Lubricating O-rings

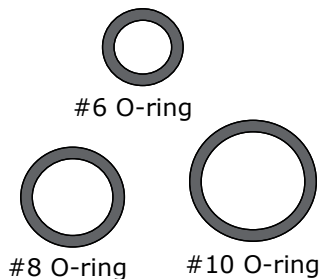

NOTE: Standard torque specifications:
#6: 11 to 13 ft-lb.
#8: 15 to 20 ft-lb.
#10: 21 to 27 ft-lb.

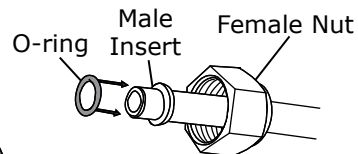

Supplied Oil for O-rings

O-ring Installs Over Male Insert to Swaged Lip

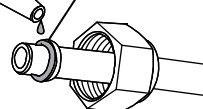

For a proper seal of fittings: Install supplied O-rings as shown, and lubricate with supplied oil.

Figure 1

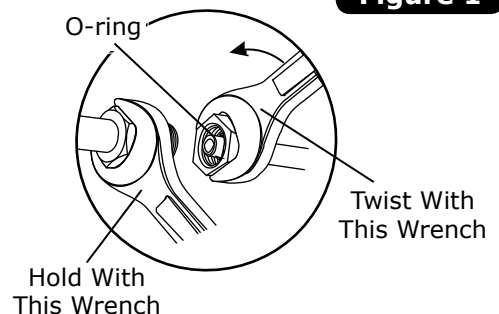



www.vintageair.com

A/C & Heater Hose Installation

1. Using a properly lubricated O-ring, route the straight, previously marked, #6 A/C hose through the bottom 1" hole on the evaporator firewall bracket, and connect it to the expansion valve, ensuring that the mark on the fitting points toward the firewall bracket/front of the truck (See Photos 1 & 2, below, and Figure 1, Page 9).
2. Using a properly lubricated O-ring, connect the 90° fitting on the #10 A/C hose to the #10 suction port on the evaporator. Direct the hose down and under the blower, and out of the remaining 1.30" hole in the evaporator bracket at the 3 o'clock position. Use the supplied tie wrap to secure the hose to the Adel clamp located under the blower (See Photos 3 & 4, below, and Figure 1, Page 9).

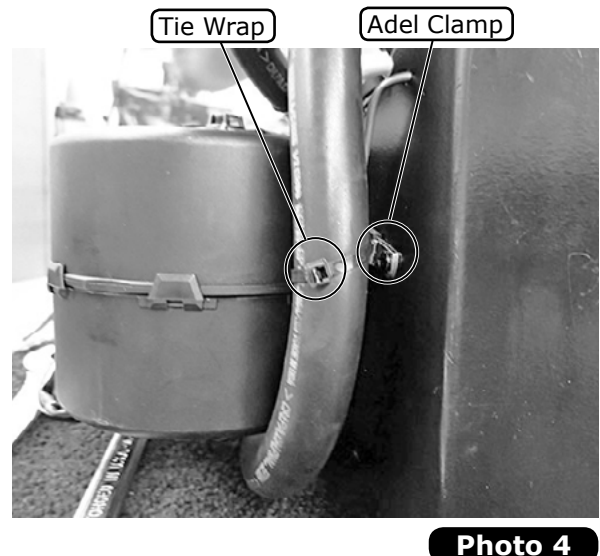
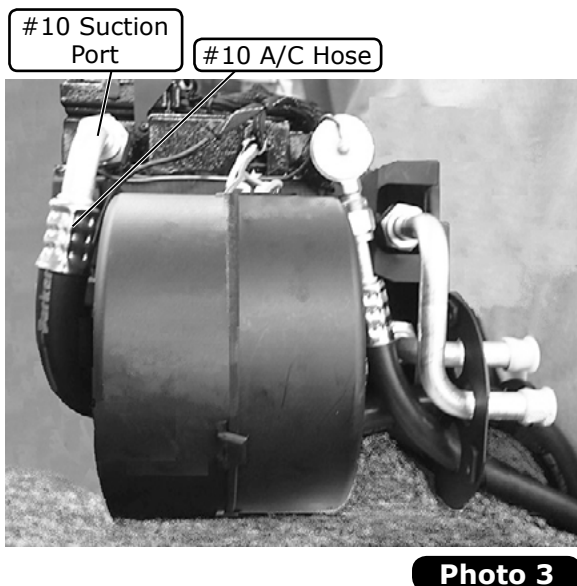
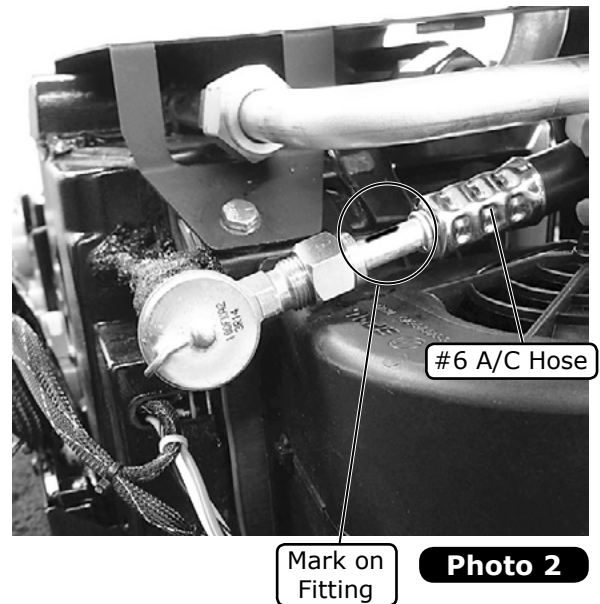
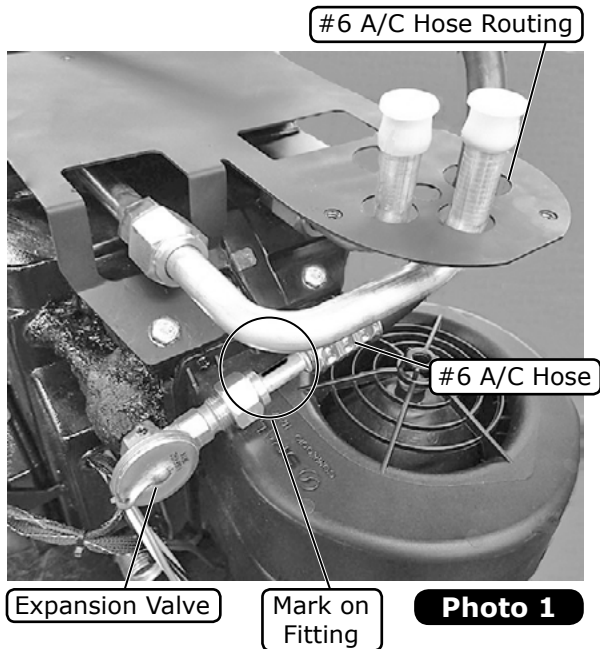



www.vintageair.com

A/C & Heater Hose Installation (Cont.)

1. Connect two pieces of heater hose approximately 45 inches long to the heater hose fittings. Using a small amount of white grease on the heater hose fittings to make slipping the hoses on easier, push the hoses past the plane of the bracket (See Photo 5, below). **NOTE: Be sure not to loosen the fitting connection nut when pushing the hoses onto the barbed heater hose fittings.** Hose clamps will be installed after the evaporator is secured to the firewall, and the rubber boot and firewall ring have been installed.
2. Insulate the #10 A/C hose fitting at the evaporator with press tape, covering all metal as shown in Photo 6, below.

Push Hose Past Plane of Bracket



Photo 5

Press Tape



#10 A/C Hose

Photo 6

Firewall Cover Installation

1. From the engine compartment, temporarily secure the firewall cover to the firewall using (2) 1/4-20 x 3/4" bolts, (2) flat washers and (2) nuts with star washers (See Photo 1, below).
2. Mark and drill (2) 5/16" holes through the upper and lower passenger side mounting holes in the firewall cover (See Photo 1, below).
3. Remove the firewall cover, and apply a bead of silicone to the back side of the firewall cover at the edge of all seams and bolt holes (See Figure 1, below). Secure the firewall cover to the firewall using (4) 1/4-20 x 3/4" bolts, (4) 1/4" flat washers and (4) 1/4-20 nuts with star washers. **NOTE: The remaining hole on the firewall cover will be used to mount the evaporator unit (See Photo 1, below). Also note, paint will not adhere to silicone.**

Drill 5/16" Hole

1/4-20 x 3/4" Bolt, Washer and Nut with Star Washer

Drill 5/16" Hole

1/4-20 x 3/4" Bolt, Washer and Nut with Star Washer



Photo 1

1/4-20 x 3/4" Bolt, Washer and Nut with Star Washer

Evaporator Mounting Hole

1/4-20 x 3/4" Bolt, Washer and Nut with Star Washer

Apply Silicone

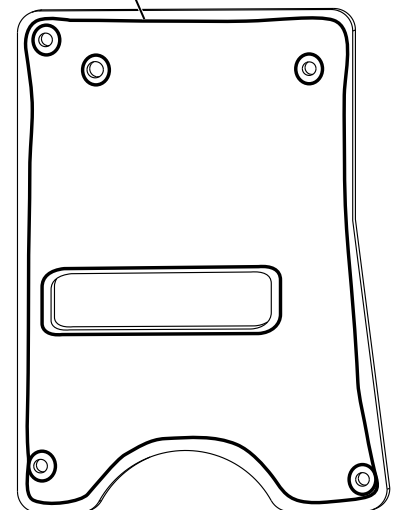

Figure 1



www.vintageair.com

Evaporator Installation

NOTE: To ensure a watertight seal between the passenger compartment and the vehicle exterior, for all bolts passing through the firewall, Vintage Air recommends coating the threads with silicone prior to installation.

1. Place the evaporator on the passenger side floorboard. Insert all hoses through the firewall hole (See Photo 1, below).
2. **OPTIONAL STEP:** Remove the heads from (2) 1/4-20 x 1 1/4" bolts (not supplied) and insert them into the evaporator firewall bracket. These studs will help align the evaporator bracket with the holes in the firewall during installation (See Photo 2, below).
3. Lift the evaporator unit up under the dashboard. Using a 1/4-20 x 1" bolt and 1/4" washer, install the bolt through the firewall cover and into the weld nut on the evaporator bracket. **NOTE: Clear away the insulation from the bolt holes on the firewall (See Photo 3, below).** Temporarily install a bolt into the top hole above the hoses on the firewall, and into the evaporator bracket. This will help hold the bracket to the firewall while the rubber boot is being installed over the hoses.
4. Insert all four hoses through the provided rubber boot, pushing the boot 4" to 6" from the firewall (See Photos 4 & 5, below). **NOTE: Soapy water may be used to ease installation of the hoses through the boot, but ensure the A/C hoses are capped to prevent water from getting inside.**

Insert All Hoses Through Firewall

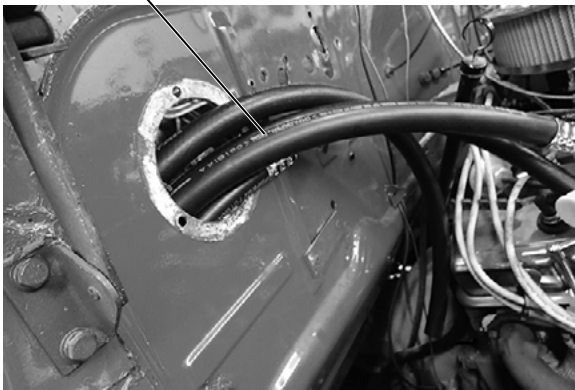

Photo 1

Firewall Bracket

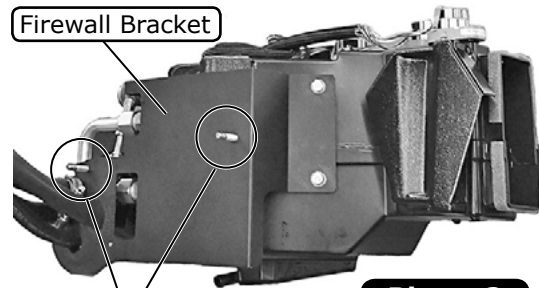

Photo 2

Studs

Rubber Boot

Wiring Harness Hole

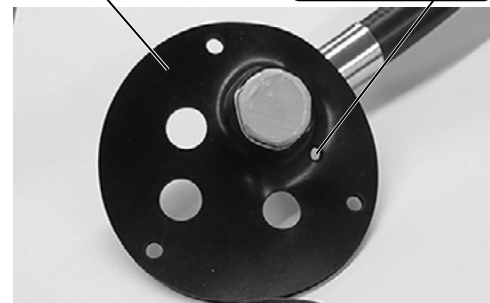

Photo 4

1/4-20 x 1" Bolt and Washer

Clear Away Insulation from Bolt Holes

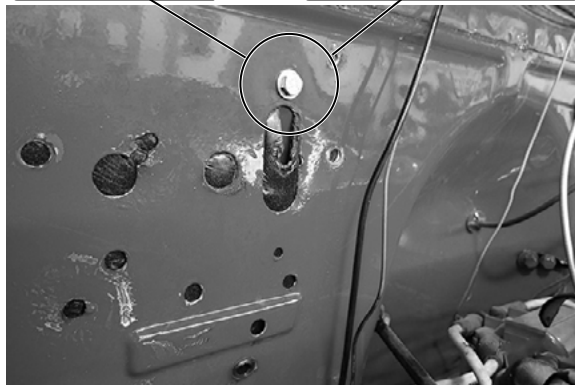

Photo 3

Insert All Four Hoses Through Push Boot

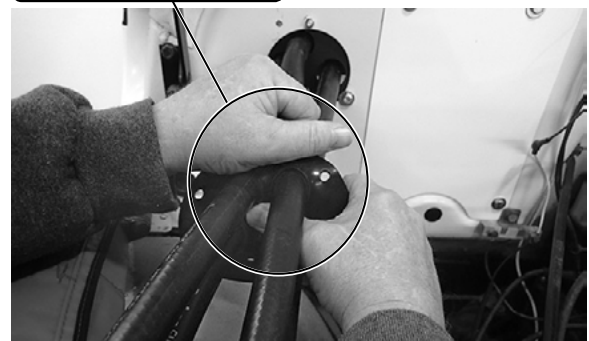

Photo 5



www.vintageair.com

Evaporator Installation (Cont.)

5. With the hoses installed through the rubber boot and the boot 4" to 6" from the firewall, feed the wiring harness from inside the passenger compartment, through the firewall and through the rubber boot (See Photos 4 & 5, Page 12, and Photo 6, below). **NOTE: Feed the heater control valve connector through the boot first. White grease may be used to ease installation.**
6. Press the rubber boot against the evaporator firewall bracket. Install the firewall ring over the hoses. **NOTE: The service port cap on the #10 A/C hose fitting must be temporarily removed to install the firewall ring.** Using (3) 1/4-20 x 1" bolts and (3) 1/4" washers, install the bolts through the firewall ring, rubber boot and firewall, and into the weld nuts on the evaporator bracket. Tighten all bolts (See Photo 7, below).
7. Install (2) hose clamps on the heater hoses in the engine compartment at the firewall ring, ensuring that they are seated past the barb on the fitting (See Photo 7, below).
8. With the evaporator attached to the firewall, hold the evaporator cowl brace bracket up to the cowl and evaporator to locate the approximate location of the 7/32" hole to be drilled from the top of the dash under the defrost vent garnish/cover (See Photo 8, below). Measure 13/16" toward the driver side from the OEM hole used to secure the defrost vent garnish/cover, and 1/2" down from the rubber windshield seal.
9. Attach the dash bracket and cowl brace bracket to the evaporator using (2) 1/4-20 x 1/2" bolts. The cowl brace bracket mounts to the evaporator sharing the driver side dash bracket bolt (See Photo 9, below). Before fully tightening the brackets to the evaporator, attach the cowl brace bracket to the cowl under the defrost garnish/cover using the previously drilled hole with a 10-32 x 1/2" pan head screw, 3/16" flat washer and 10-32 nut with star washer (See Photo 10, below). Tighten the bracket bolts.
10. Reinstall the defrost vent garnish/cover to the dash.



Feed Wiring Harness Through Firewall and Rubber Boot

Photo 6

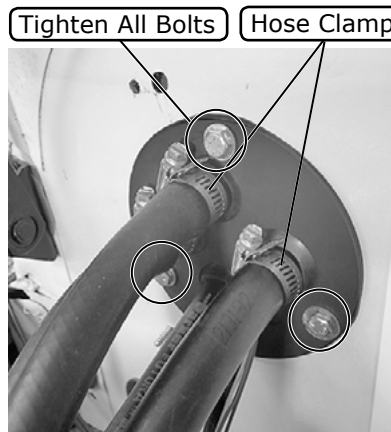

Photo 7

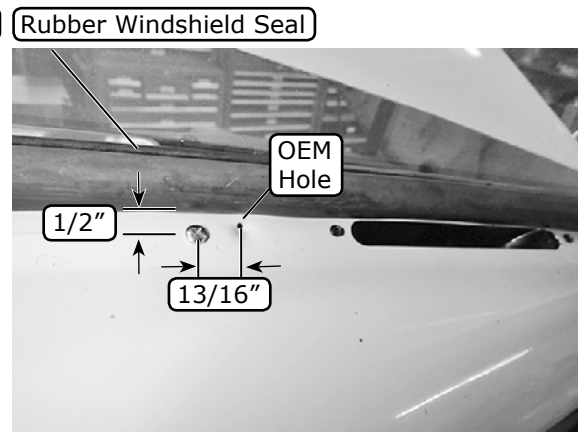

Photo 8

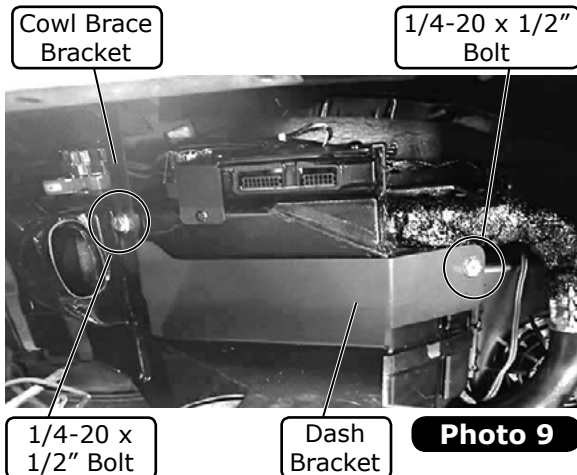

Photo 9

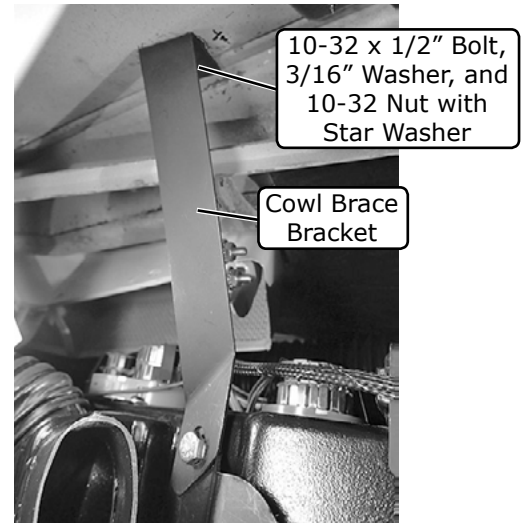

Photo 10



www.vintageair.com

Rotary Pot Installation

1. Locate the (3) rotary pot assemblies, and install them into the louver bezel as shown below.
2. Tie wrap the wires to the rotary pots as shown below.

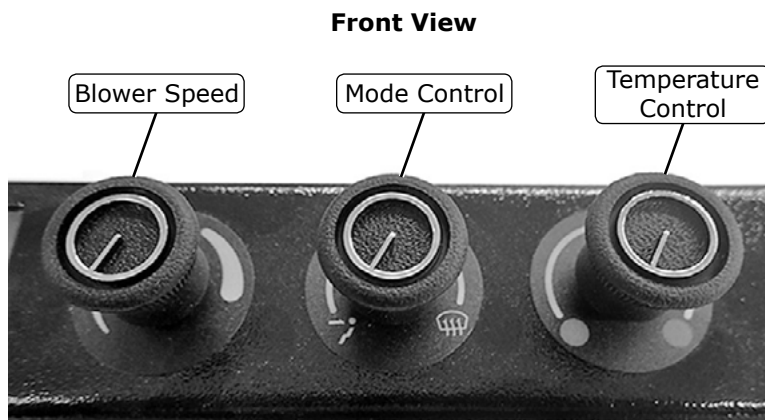
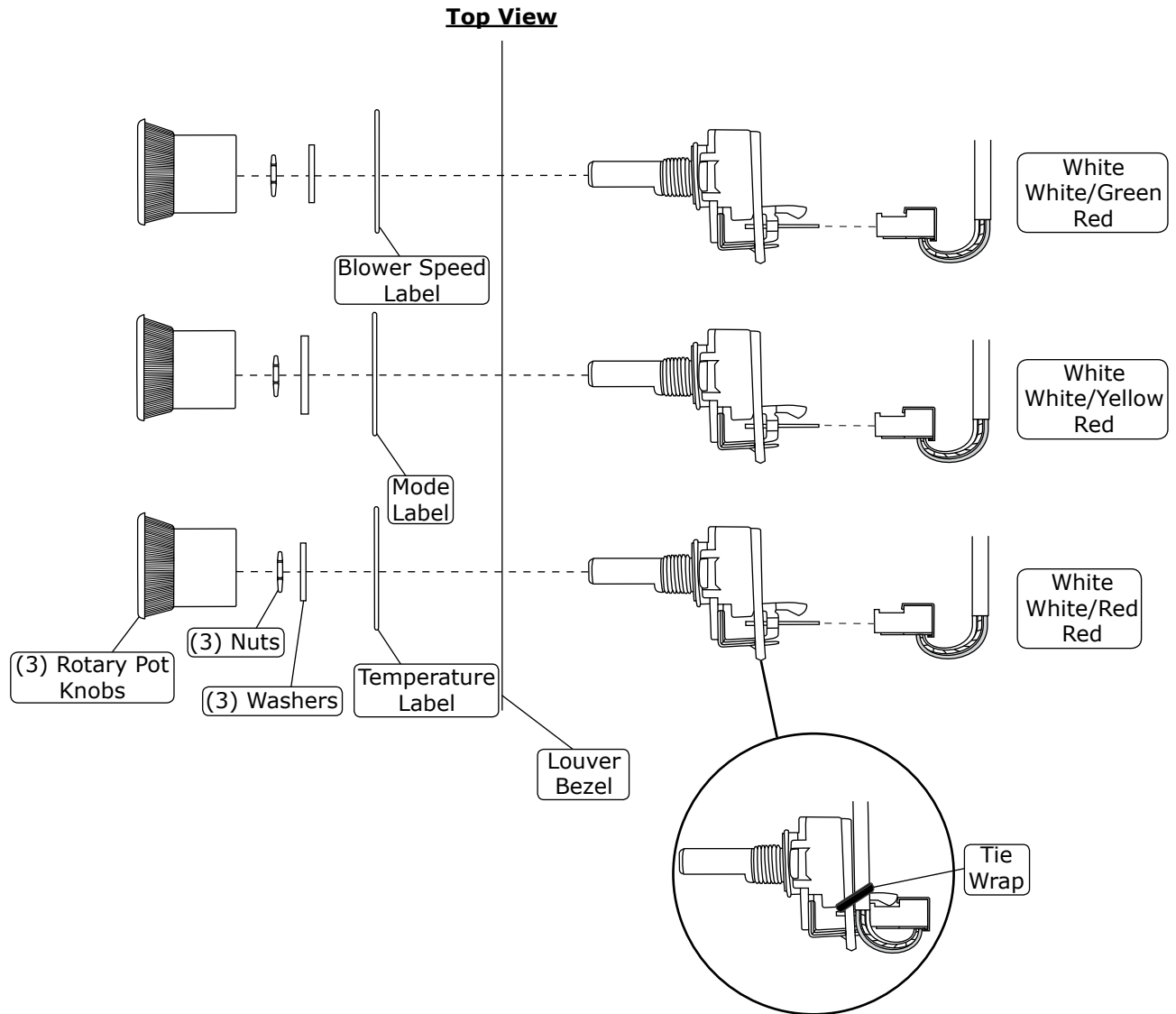



www.vintageair.com

Control Panel/ Louver Bezel Assembly Installation

1. Before attaching the dash bracket to the dash, install the control panel/louver bezel assembly.
 - A. Locate the (2) OEM 5/16" bolts under the far passenger side of the dash. Remove the inner 5/16" bolt (retain). **NOTE: This bolt will be reinstalled through the louver bezel in Step D, below. The bezel has a clearance hole for the outer bolt.**
 - B. Align the predrilled holes on the louver bezel with the (2) OEM mounting holes under the dash.
 - C. Secure the control panel/louver bezel assembly under the dash using (2) 10-32 x 3/4" pan head screws, (4) 3/16" flat washers and (2) 10-32 nuts with star washers (See Photos 1 & 2, below).
 - D. Reinstall the 5/16" bolt that was removed in Step A, above (See Photo 3, below).
 - E. Insert the louvers into the louver bezel.

10-32 x 3/4" Pan Head Screw, (2) 3/16" Flat Washers, and 10-32 Nut with Star Washer



Photo 1

10-32 x 3/4" Pan Head Screw, (2) 3/16" Flat Washers, and 10-32 Nut with Star Washer



Photo 2

Remove Inner 5/16" Bolt and Reuse to Mount Control Panel/Louver Bezel Assembly



Photo 3



www.vintageair.com

Evaporator Installation (Final)

1. With the louver bezel mounted and the dash bracket secured to the evaporator, drill a 7/32" hole aligned with the center of the slot on the dash bracket. Drill through the OEM dash brace, the bottom of the dash and the top of the louver bezel. Attach the dash bracket to the dash through all drilled holes using a 10-32 x 1" pan head screw, (2) 3/16" flat washers, and a 10-32 nut with star washer (See Photo 1 and Figure 1, below).

NOTE: Install this screw upward from the louver bezel.

2. Check that the evaporator unit is level at the passenger side of the drain pan (See Photo 2, below). If the unit is not level, check to ensure installation steps were properly performed.

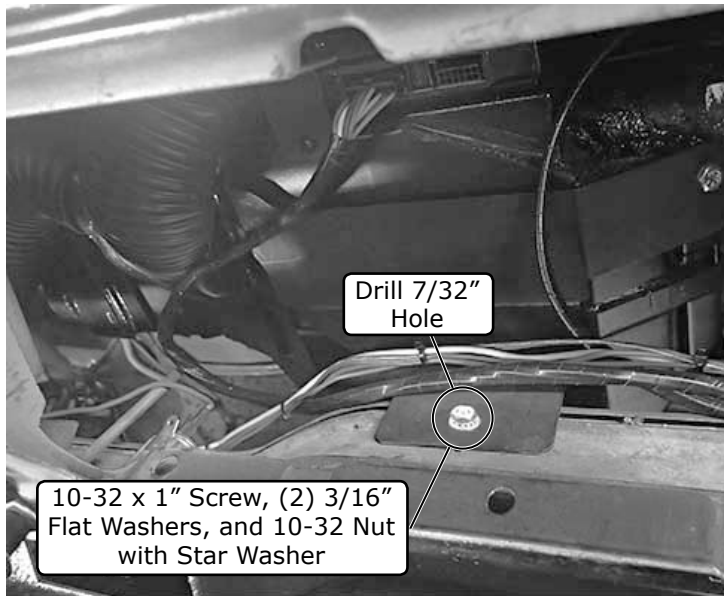

Photo 1

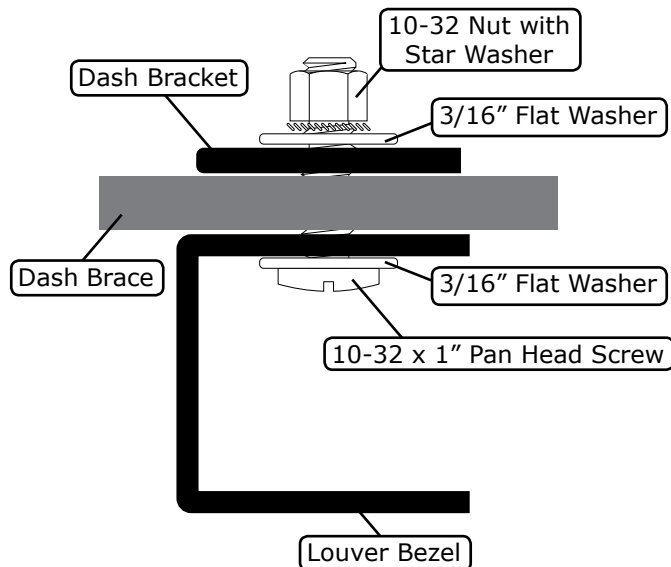

Figure 1

Check that Evaporator Unit is Level
at Passenger Side of Drain Pan

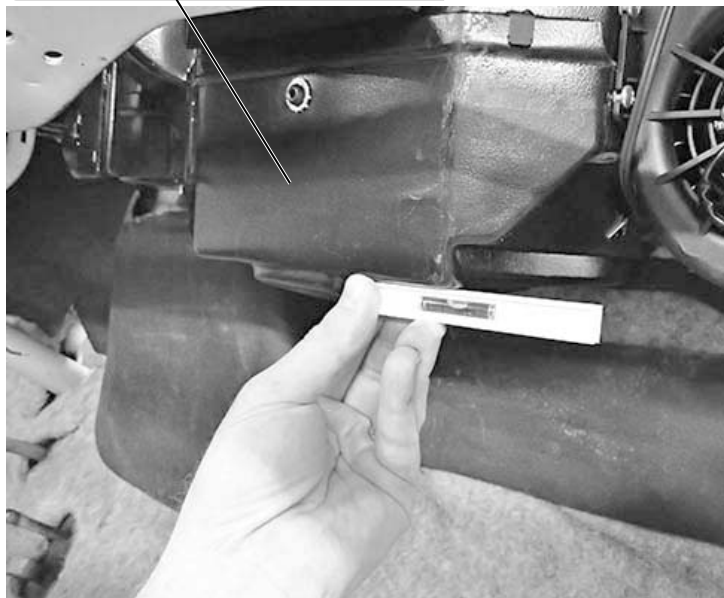

Photo 2



www.vintageair.com

Driver Side Under Dash Louver Installation

1. Align the inner hole on the driver side louver bezel with the OEM hole under the dash as shown in Photo 1, below. Using the bezel's outer hole as a template, mark and drill a hole into the bottom of the dash. Install the driver side louver bezel using (2) 10-32 x 3/4" pan head screws, (4) 3/16" flat washers and (2) 10-32 nuts with star washers (See Photo 1, below).
2. Insert the louvers into the louver housing (See Photo 2, below).

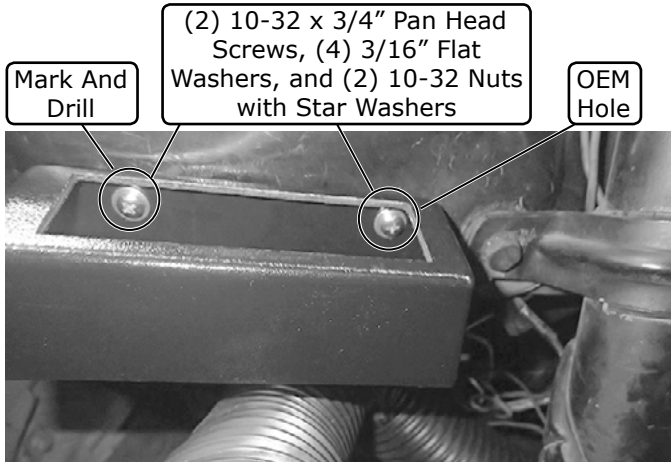

Photo 1

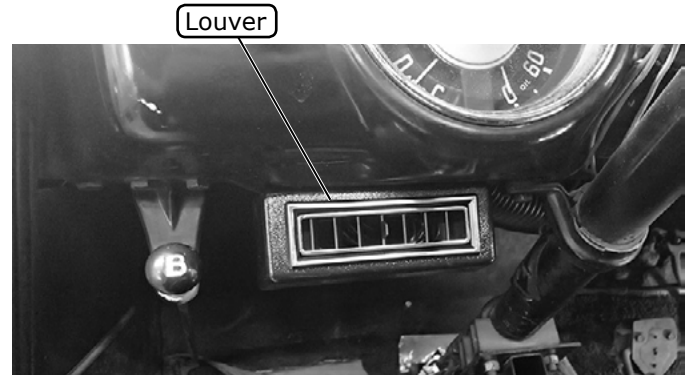

Photo 2

Heater Control Valve Installation

1. With the evaporator installed and (4) hoses exiting the firewall, cut the heater hose located at the 12 o'clock position, 6 1/2" from the firewall. Slide a hose clamp over the hose coming out of the firewall, push the valve onto the hose and tighten the clamp. Connect the remaining hose to the other end of the valve, and clamp the hose. **NOTE: The arrow molded on the heater control valve body needs to point toward the firewall (See Photo 1, below). Ideally, the valve should be mounted as shown in Photo 1, below. However, the valve can be rolled 90° as shown in Photo 2, below. White grease may be used on the valve barbs to ease installation.**

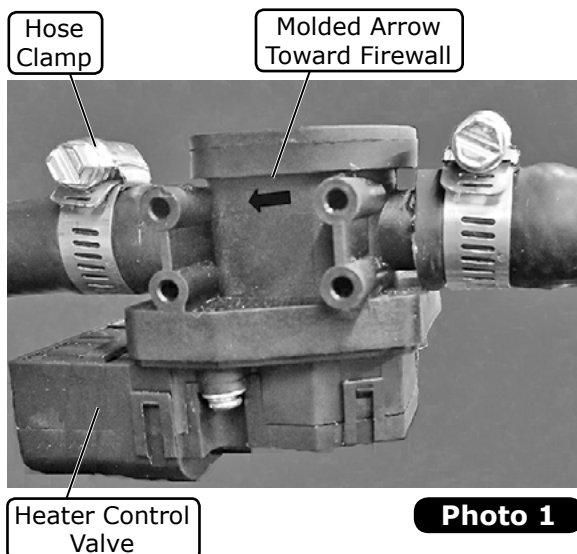

Photo 1

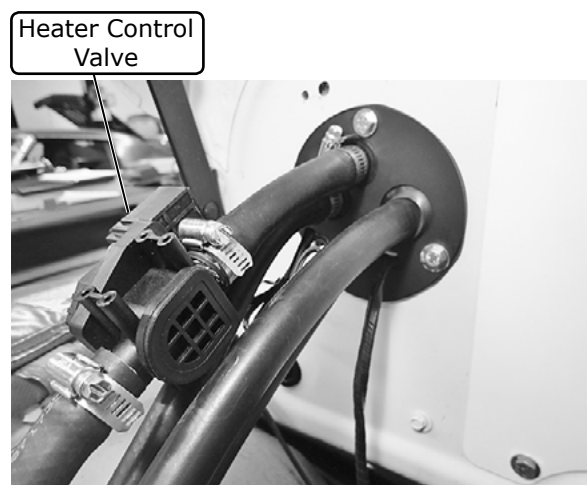

Photo 2



www.vintageair.com

A/C & Heater Hose Installation, V-8 Engines (Final)

1. Using a properly lubricated O-ring, connect the #6 A/C hose to the #6 condenser hardline (See Photo 1, below, and Figure 1, Page 9).
2. Using a properly lubricated O-ring, connect the #10 A/C hose to the compressor (See Photo 2, below, and Figure 1, Page 9).
3. Using a properly lubricated O-ring, connect the straight fitting on the #8 A/C hose to the #8 hardline from the condenser. Connect the 135° fitting to the compressor (See Photo 2, below, and Figure 1, Page 9).
4. Connect the heater hose from the heater control valve to the intake manifold. Secure with a hose clamp (See Photo 2, below).
5. Connect the remaining heater hose to the water pump. Secure with a hose clamp (See Photo 2, below).

NOTE: Vintage Air systems require (2) 5/8" hose nipples (Not Supplied).

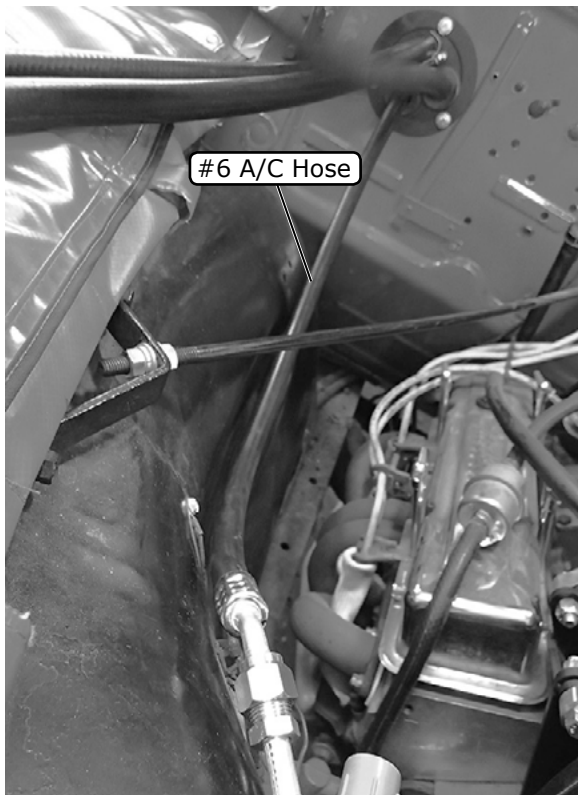

Photo 1

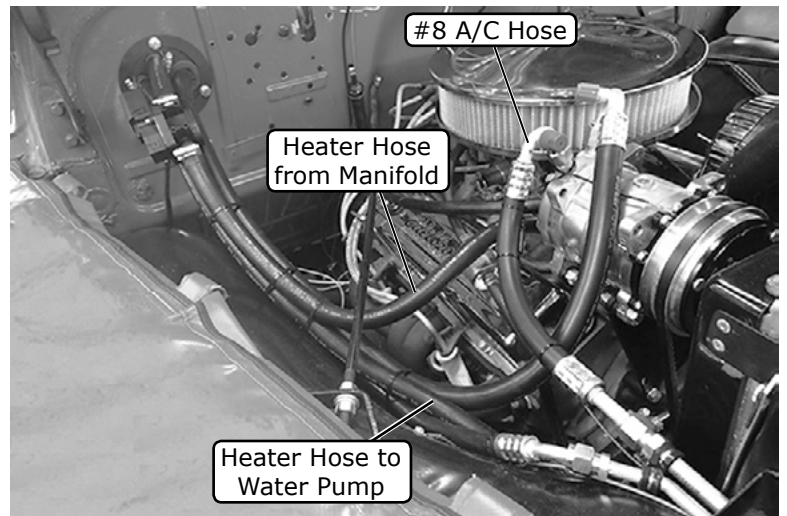

Photo 2



www.vintageair.com

A/C & Heater Hose Installation, 6-Cylinder Engines (Final)

NOTE: On 6-cylinder engine compartments, there are multiple possibilities for routing the #8 and #10 A/C hoses, depending on the installer's preference. For this reason, the #8 and #10 hoses are shipped with fittings installed on one end only. The other end will need to be cut and crimped after routing has been determined. For our installation, Vintage Air's technicians routed the hoses beneath the engine, securing them to the front frame crossmember with (2) #10 Adel clamps as shown below.

1. Using a properly lubricated O-ring, connect the #6 A/C hose to the #6 condenser hardline (See Photo 1, Page 18, and Figure 1, Page 9).
2. From where it exits the firewall, route the #10 A/C hose to the compressor. Temporarily attach the 135° fitting to the compressor. Cut the hose to the proper length, and connect the hose to the compressor fitting. Mark the fitting and hose to ensure proper positioning, and remove the fitting from the compressor. Crimp the fitting onto the hose, and permanently connect to the compressor using a properly lubricated O-ring (See Photos 1 & 2, below, and Figure 1, Page 9).
3. Using a properly lubricated O-ring, connect the 90° fitting on the #8 A/C hose to the #8 condenser hardline. From there, route the #8 hose to the compressor. Temporarily attach the 135° fitting to the compressor. Cut the hose to the proper length, and connect the hose to the compressor fitting. Mark the fitting and hose to ensure proper positioning, and remove the fitting from the compressor. Crimp the fitting onto the hose, and permanently connect to the compressor using a properly lubricated O-ring (See Photos 1 & 2, below, and Figure 1, Page 9).
4. Connect the heater hose from the heater control valve to the water neck. Secure with a hose clamp (See Photo 3, below).
5. Connect the remaining heater hose to the water pump. Secure with a hose clamp (See Photo 3, below).

NOTE: Vintage Air systems require (2) 5/8" hose nipples (Not Supplied).

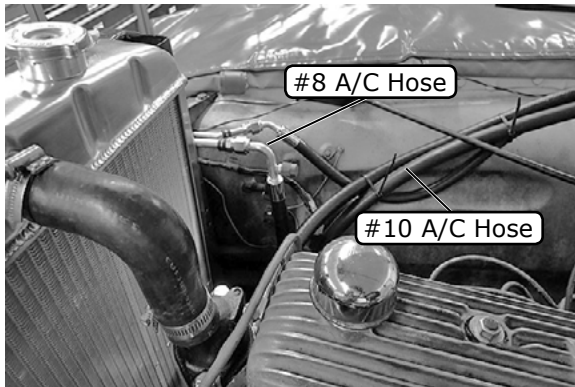

Photo 1

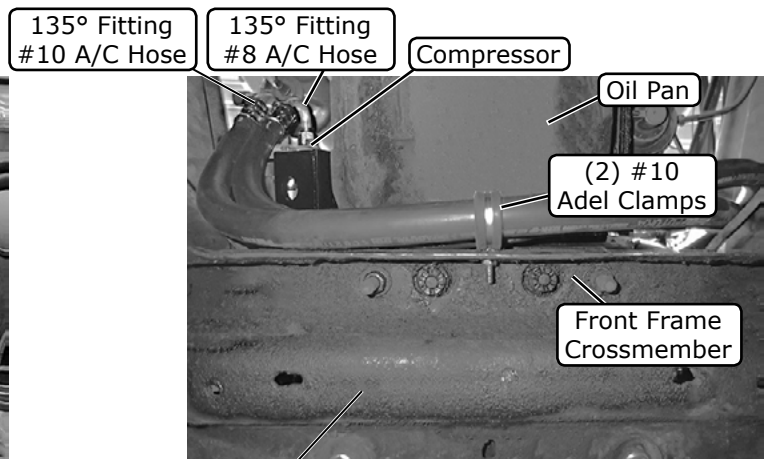

Photo 2

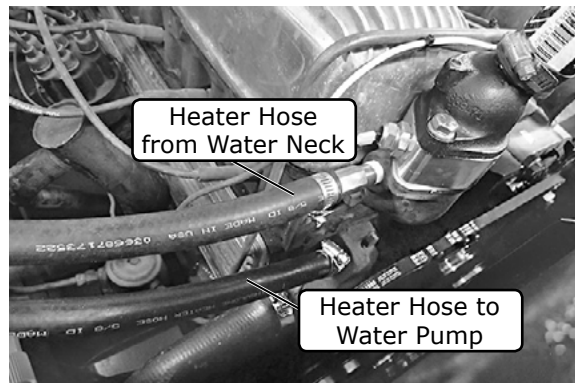

Photo 3



www.vintageair.com

Control Panel & Duct Hose Routing

1. Install the duct hoses as shown in Figure 1, below. **NOTE: Do not route duct hoses over the ECU. Duct hoses may sweat and drip onto/into the ECU, causing a malfunction.**

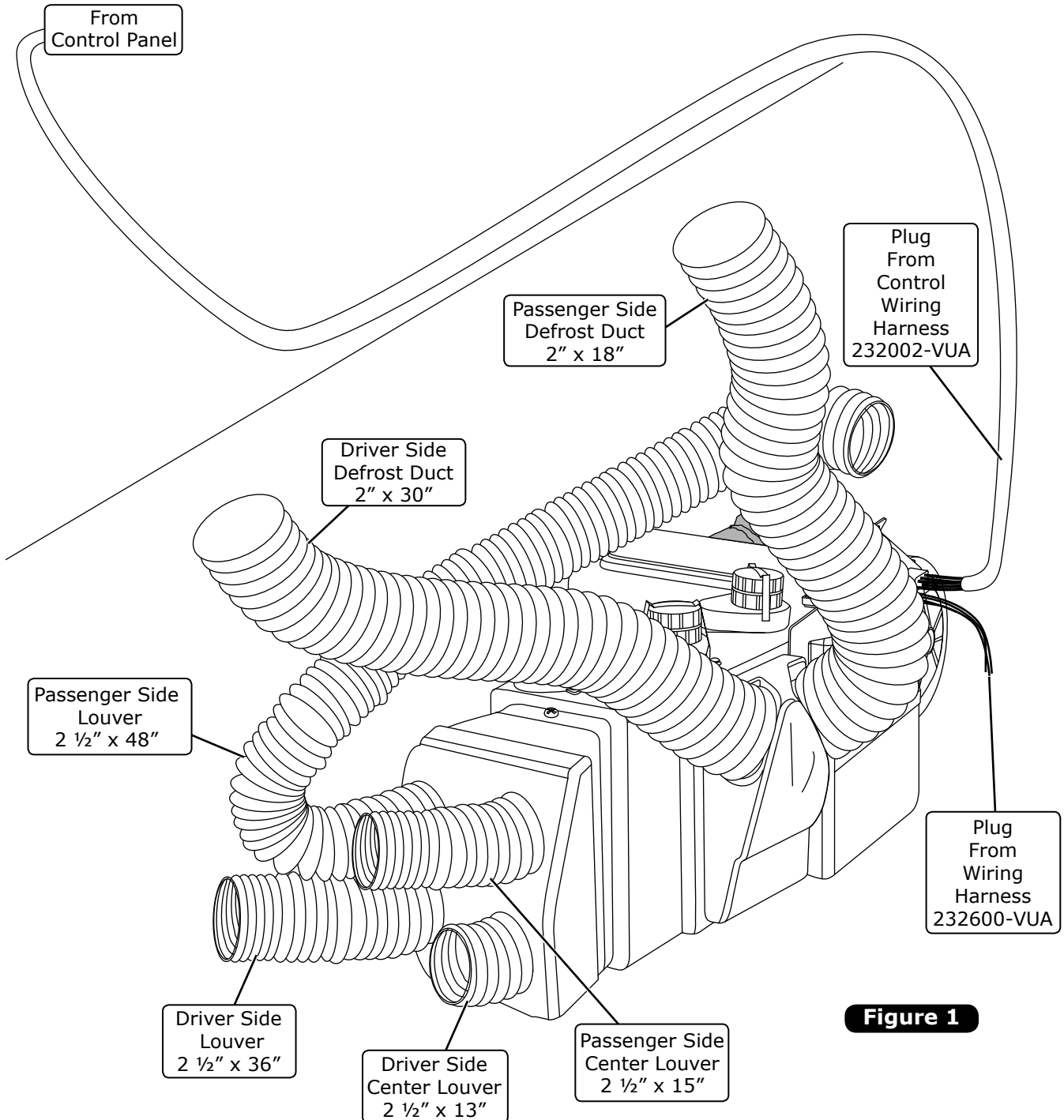

Figure 1



www.vintageair.com

Wiring

1. Plug the wiring harnesses into the ECU module on the sub case. Wire according to the wiring diagrams on Pages 24 & 25.
2. Run the red and (2) white wires to the battery box in the passenger compartment. Using (2) 10-32 x 3/4" pan head screws and (2) 10-32 nuts, mount the circuit breaker near the battery (See Photos 1, 2 & 3, below).

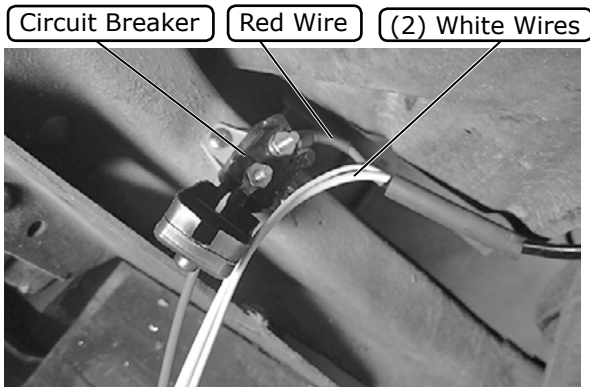

Photo 1

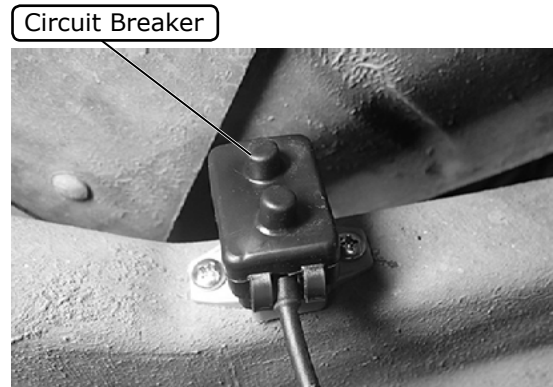

Photo 2

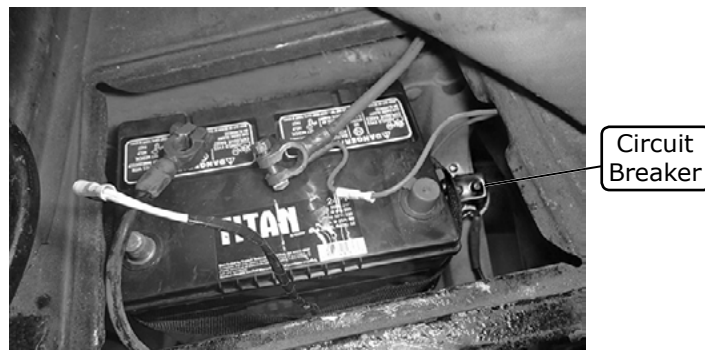

Photo 3



www.vintageair.com

Glove Box Installation (1950-52 Vehicles)

1. Using the OEM glove box screws, install the glove box provided with the kit (See Photo 1, below). **NOTE: Loosely install all screws before tightening.**
2. Reinstall the glove box door (See Photo 2, below).

Glove Box



Photo 1

Glove Box Door



Photo 2

Glove Box Installation (1953 Vehicles)

1. Install (6) #8 U-Nuts onto the glove box, and install the glove box (See Photo 1, below). **NOTE: Loosely install all screws before tightening.**
2. Reinstall the glove box door (See Photo 2, below).

Glove Box



Photo 1

Glove Box Door

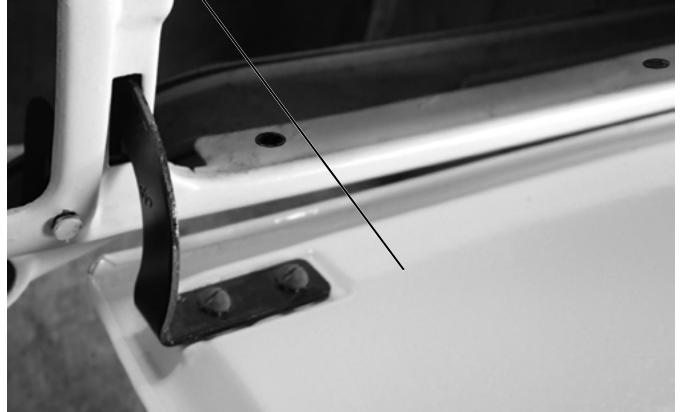

Photo 2



www.vintageair.com

Drain Hose Installation

1. Locate the evaporator drain on the bottom of the evaporator case. In line with the drain, drill a 5/8" hole through the floor where it meets the firewall (See Photos 1 & 2, below). Cut a 3" to 4" piece of drain hose, and connect it to the 1/2" 90° elbow. Connect the long piece of drain hose to the 90° elbow. From inside the truck, push the tail end of the drain hose through the hole in the floorboard. With the elbow against the firewall, measure and cut the hose, and then push it onto the evaporator drain pan fitting. Ensure that the hose from the drain pan has adequate drop to allow drainage (See Photo 3, below). On the engine side of the firewall, cut the hose and install the second 90° elbow. Attach the remaining hose to the elbow, and route to drain below the cab (See Photo 4, below). Seal with silicone around the hose at the floorboard to prevent water from coming in.

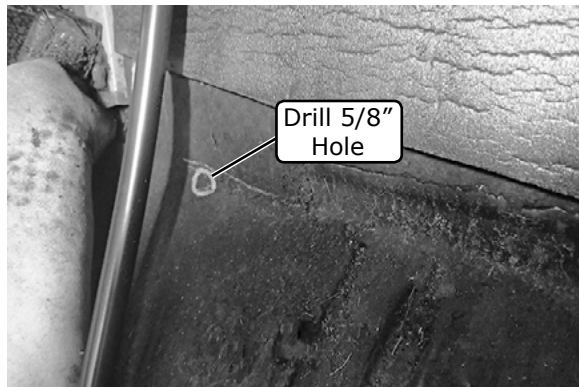

Photo 1

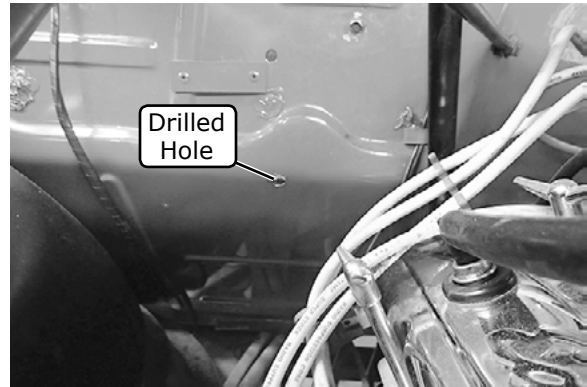

Photo 2

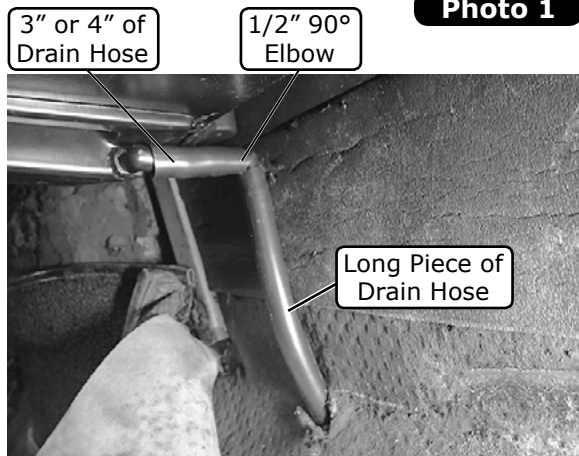

Photo 3

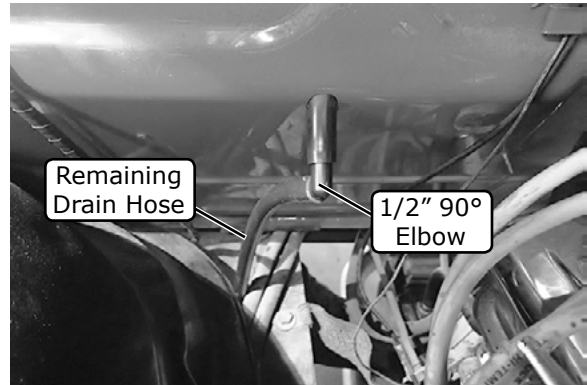

Photo 4

Final Steps

1. Reinstall all previously removed items.
2. Fill radiator with at least a 50/50 mixture of approved antifreeze and distilled water. It is the owner's responsibility to keep the freeze protection at the proper level for the climate in which the vehicle is operated. Failure to follow antifreeze recommendations will cause heater core to corrode prematurely and possibly burst in A/C mode and/or freezing weather, voiding your warranty.
3. Double check all fittings, brackets and belts for tightness.
4. Vintage Air recommends that all A/C systems be serviced by a licensed automotive A/C technician.
5. Evacuate the system for a minimum of 45 minutes prior to charging, and perform a leak check prior to servicing.
6. Charge the system to the capacities stated on Page 4 of this instruction manual.
7. See Operation of Controls procedures on Page 26.



www.vintageair.com

Wiring Diagram

232007-VUR

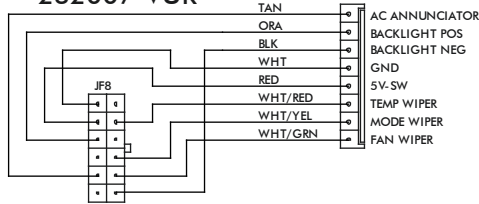

VIEWED FROM WIRE SIDE

232002-VUA

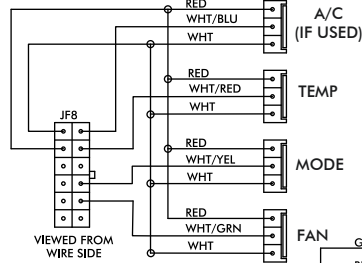

VIEWED FROM WIRE SIDE

GEN IV ECU

GEN IV WIRING DIAGRAM
REV E, 10/6/2017

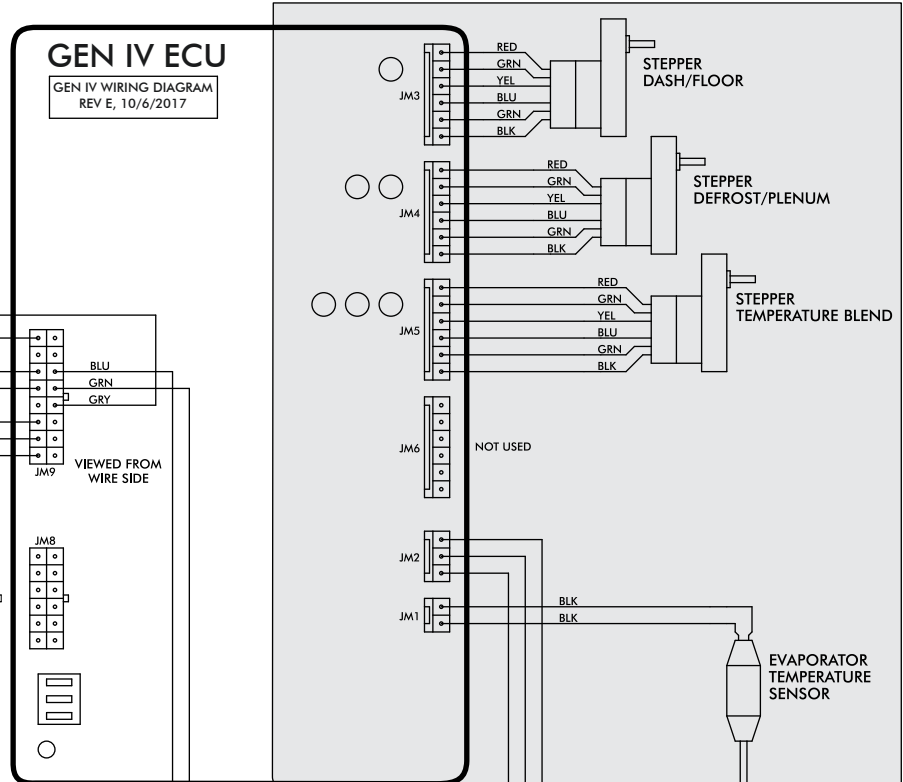

PRE-WIRED

PROGRAM

N/A

* DASH LAMP (IF USED)

*** WIDE OPEN THROTTLE SWITCH (OPTIONAL)

WHT

IGNITION SWITCH +12v

** CIRCUIT BREAKER 30 AMP

COMPR

COMPR RELAY

COMPR

COMPR

COMPR

COMPR

COMPR

COMPR

COMPR

COMPR

COMPR

COMPR

COMPR

COMPR

COMPR

COMPR

COMPR

COMPR

COMPR

COMPR

COMPR

COMPR

COMPR

COMPR

COMPR

NOTE: = CHASSIS GROUND

* Dash Lamp Is Used Only With Type 232007-VUR Harness.

** Warning: Always Mount Circuit Breaker As Close to the Battery As Possible. (NOTE: Wire Between Battery and Circuit Breaker Is Unprotected and Should Be Carefully Routed to Avoid a Short Circuit).

*** Wide Open Throttle Switch Contacts Close Only at Full Throttle, Which Disables A/C Compressor.



www.vintageair.com

Gen IV Wiring Connection Instruction

WIRING HARNESS

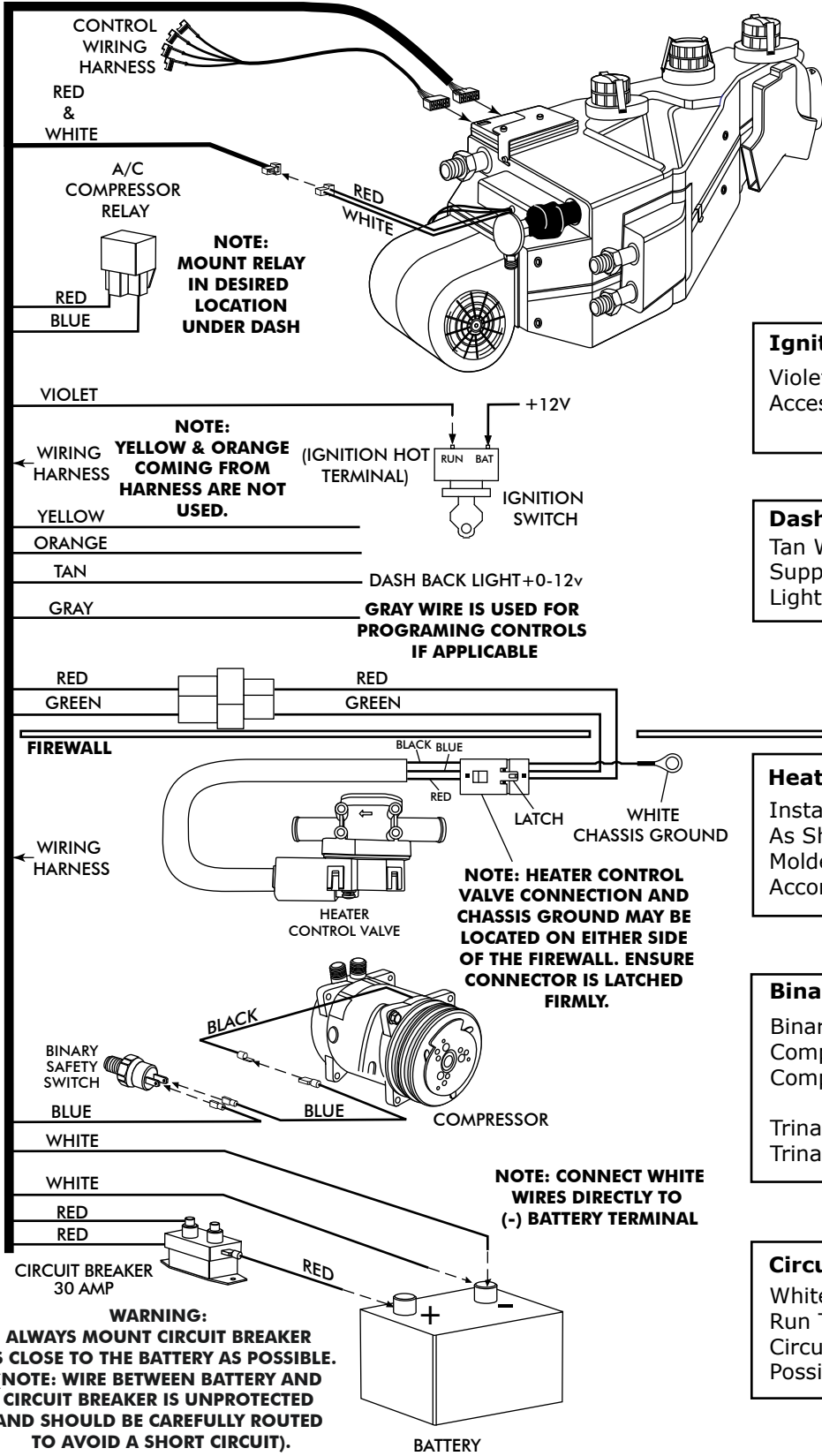

NOTE:
MOUNT RELAY
IN DESIRED
LOCATION
UNDER DASH

NOTE:
YELLOW & ORANGE
COMING FROM
HARNESS ARE NOT
USED.

**GRAY WIRE IS USED FOR
PROGRAMMING CONTROLS
IF APPLICABLE**

**NOTE: HEATER CONTROL
VALVE CONNECTION AND
CHASSIS GROUND MAY BE
LOCATED ON EITHER SIDE
OF THE FIREWALL. ENSURE
CONNECTOR IS LATCHED
FIRMLY.**

**NOTE: CONNECT WHITE
WIRES DIRECTLY TO
(-) BATTERY TERMINAL**

WARNING:
ALWAYS MOUNT CIRCUIT BREAKER
AS CLOSE TO THE BATTERY AS POSSIBLE.
(NOTE: WIRE BETWEEN BATTERY AND
CIRCUIT BREAKER IS UNPROTECTED
AND SHOULD BE CAREFULLY ROUTED
TO AVOID A SHORT CIRCUIT).

Ignition Switch:
Violet 12V Ign Switch Source (Key On Accessory) Position Must Be Switched.

Dash Light:
Tan Wire Used Only With Vintage Air Supplied Control Panel With LED Back Light.

Heater Control Valve:
Install With Servo Motor Facing Down, As Shown. Note Flow Direction Arrow Molded Into Valve Body, And Install Accordingly.

Binary/Trinary & Compressor:
Binary: Connect As Shown (Typical Compressor Wiring). Be Sure Compressor Body Is Grounded.
Trinary Switch: Connect According To Trinary Switch Wiring Diagram.

Circuit Breaker/Battery:
White **Must** Run To (-) Battery. Red May Run To (+) Battery Or Starter. Mount Circuit Breaker As Close to Battery As Possible.



www.vintageair.com

Operation of Controls

On Gen IV systems with three lever/knob controls, the temperature control toggles between heat and A/C operations. To activate A/C, move the temperature lever/knob all the way to cold and then back it off to the desired vent temperature. For heat operation, move the temperature lever/knob all the way to hot and then adjust to the desired vent temperature. The blower will momentarily change speed, each time you toggle between operations, to indicate the change. **NOTE: For proper control panel function, refer to control panel instructions for calibration procedure.**

Blower Speed

This lever/knob controls blower speed, from OFF to HI.

Mode Control

This lever/knob controls the mode positions, from DASH to FLOOR to DEFROST, with a blend in between.

Temperature Control

This lever/knob controls the temperature, from HOT to COLD.

Blower Speed

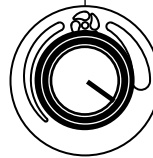

Mode Control



Temperature Control

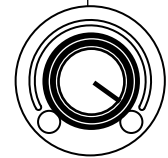

A/C Operation

Blower Speed

Adjust to desired speed.

Mode Control

Adjust to desired mode position (DASH position recommended).

Temperature Control

For A/C operation, adjust to coldest position to engage compressor (Adjust between HOT and COLD to reach desired temperature).

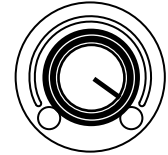
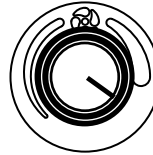

Heat Operation

Blower Speed

Adjust to desired speed.

Mode Control

Adjust to desired mode position (FLOOR position recommended).

Temperature Control

For maximum heating, adjust to hottest position (Adjust between HOT and COLD to reach desired temperature).

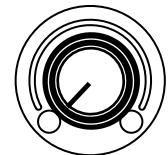
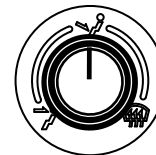

Defrost/De-fog Operation

Blower Speed

Adjust to desired speed.

Temperature Control

Adjust to desired temperature.

Mode Control

Adjust to DEFROST position for maximum defrost, or between FLOOR and DEFROST positions for a bi-level blend (Compressor is automatically engaged).

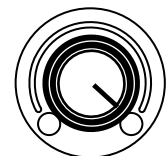



www.vintageair.com

Troubleshooting Guide

Symptom	Condition	Checks	Actions	Notes
1a. Blower stays on high speed when ignition is on.	No other functions work.	Check for damaged pins or wires in control head plug.	Verify that all pins are inserted into plug. Ensure that no pins are bent or damaged in ECU.	Loss of ground on this wire renders control head inoperable.
	All other functions work.	Check for damaged ground wire (white) in control head harness. Check for damaged blower switch or potentiometer and associated wiring.	Verify continuity to chassis ground with white control head wire at various points.	See blower switch check procedure.
1b. Blower stays on high speed when ignition is on or off.		Unplug 3-wire BSC control connector from ECU. If blower shuts off, ECU is either improperly wired or damaged.	Be sure the small, 20 GA white ground wire is connected to the battery ground post. If it is, replace the ECU.	
		Unplug 3-wire BSC control connector from ECU. If blower stays running, BSC is either improperly wired or damaged.	Check to ensure that no BSC wiring is damaged or shorted to vehicle ground. The BSC operates the blower by ground side pulse width modulation switching. The positive wire to the blower will always be hot. If the "ground" side of the blower is shorted to chassis ground, the blower will run on HI. Replace BSC (This will require removal of evaporator from vehicle).	No other part replacements should be necessary.
2. Compressor will not turn on (All other functions work).	System is not charged.	System must be charged for compressor to engage.	Charge system or bypass pressure switch.	Danger: Never bypass safety switch with engine running. Serious injury can result.
	System is charged.	Check for faulty A/C potentiometer or associated wiring (Not applicable to 3-pot controls). Check for disconnected or faulty thermistor.	Check continuity to ground on white control head wire. Check for 5V on red control head wire. Check 2-pin connector at ECU housing.	To check for proper pot function, check voltage at white/blue wire. Voltage should be between 0V and 5V, and will vary with pot lever position. Disconnected or faulty thermistor will cause compressor to be disabled.
3. Compressor will not turn off (All other functions work).		Check for faulty A/C potentiometer or associated wiring.	Repair or replace pot/control wiring.	Red wire at A/C pot should have approximately 5V with ignition on. White wire will have continuity to chassis ground. White/Blue wire should vary between 0V and 5V when lever is moved up or down.
		Check for faulty A/C relay.	Replace relay.	

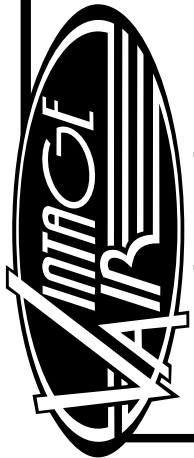

www.vintageair.com

Troubleshooting Guide (Cont.)

Symptom	Condition	Checks	Actions	Notes
4. System will not turn on, or runs intermittently.	Works when engine is not running; shuts off when engine is started (Typically early Gen IV, but possible on all versions).	Noise interference from either ignition or alternator.	Install capacitors on ignition coil and alternator. Ensure good ground at all points. Relocate coil and associated wiring away from ECU and ECU wiring. Check for burned or loose plug wires.	Ignition noise (radiated or conducted) will cause the system to shut down due to high voltage spikes. If this is suspected, check with a quality oscilloscope. Spikes greater than 16V will shut down the ECU. Install a radio capacitor at the positive post of the ignition coil (See radio capacitor installation bulletin). A faulty alternator or worn out battery can also result in this condition.
	Will not turn on under any conditions.	Verify connections on power lead, ignition lead, and both white ground wires.	Check for positive power at heater valve green wire and blower red wire. Check for ground on control head white wire.	
		Verify battery voltage is greater than 10 volts and less than 16.	Verify proper meter function by checking the condition of a known good battery.	
5. Loss of mode door function.	No mode change at all.	Check for damaged mode switch or potentiometer and associated wiring.		Typically caused by evaporator housing installed in a bind in the vehicle. Be sure all mounting locations line up and don't have to be forced into position.
	Partial function of mode doors.	Check for obstructed or binding mode doors.		
		Check for damaged stepper motor or wiring.		
6. Blower turns on and off rapidly.	Battery voltage is at least 12V.	Check for at least 12V at circuit breaker.	Ensure all system grounds and power connections are clean and tight.	System shuts off blower at 10V. Poor connections or weak battery can cause shutdown at up to 11V.
	Battery voltage is less than 12V.	Check for faulty battery or alternator.	Charge battery.	
7. Erratic functions of blower, mode, temp, etc.		Check for damaged switch or pot and associated wiring.	Repair or replace.	
		This is an indicator that the system has been reset. Be sure the red power wire is on the battery post, and not on a switched source. Also, if the system is pulled below 7V for even a split second, the system will reset.	Run red power wire directly to battery.	



Packing List: Evaporator Kit (754562)

No.	Qty.	Part No.	Description
1.	1	744004-VUE	Gen IV Evaporator Sub Case, 4-Vent
2.	1	799003	Accessory Kit

Checked By: _____
 Packed By: _____
 Date: _____

1

**Gen IV Evaporator
Sub Case 4-Vent
744004-VUE**

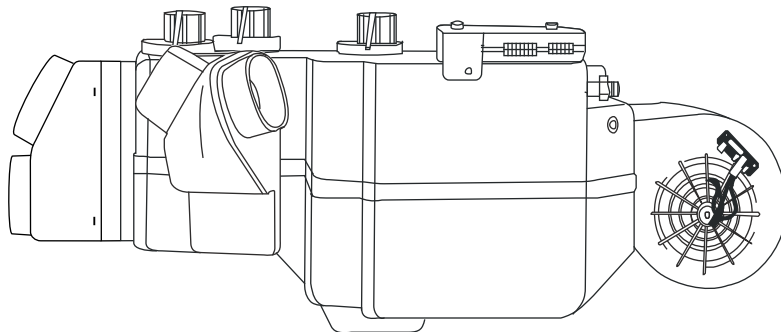

2

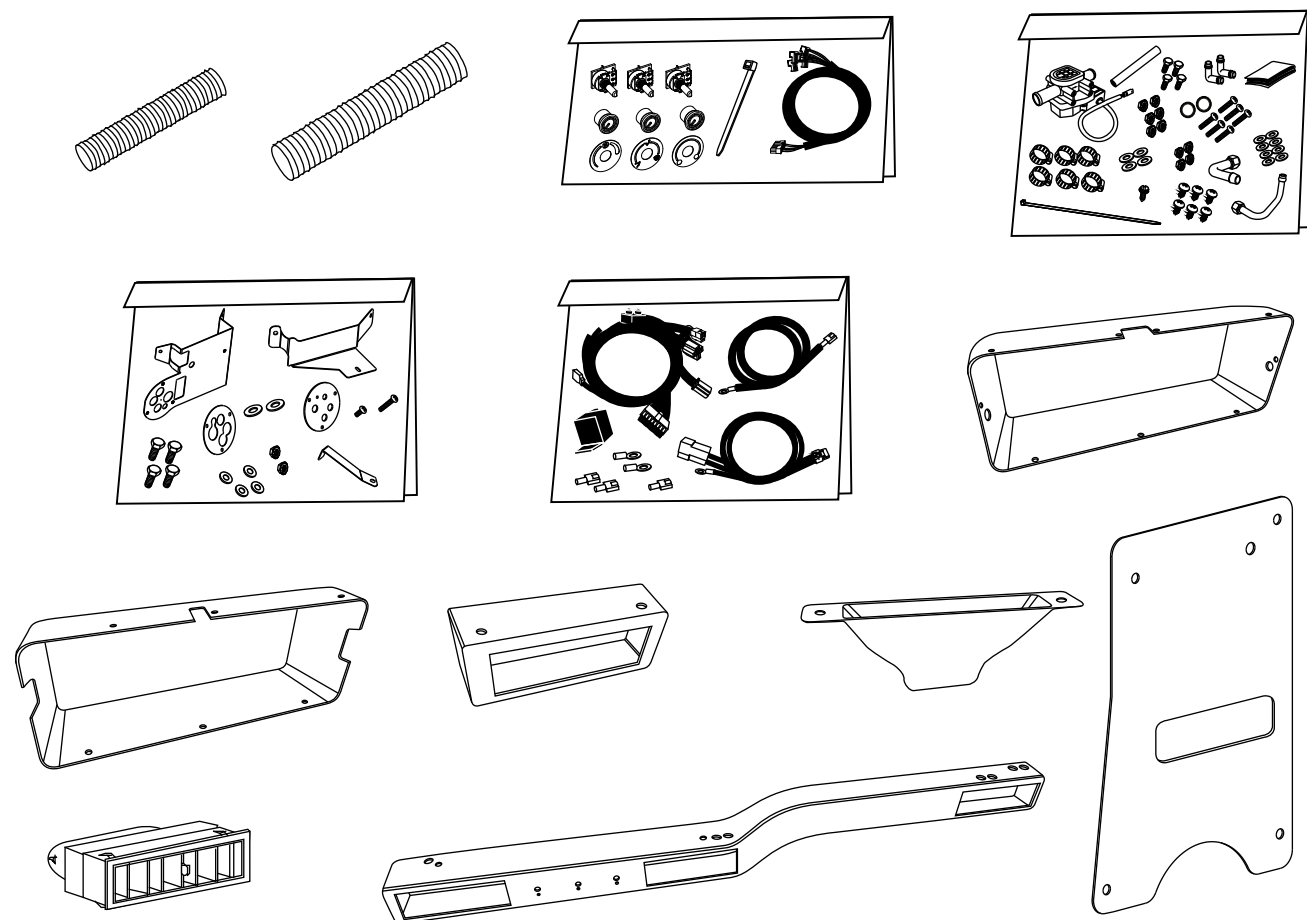

**Accessory Kit
799003**

**NOTE: Images may not depict actual parts and quantities.
Refer to packing list for actual parts and quantities.**