

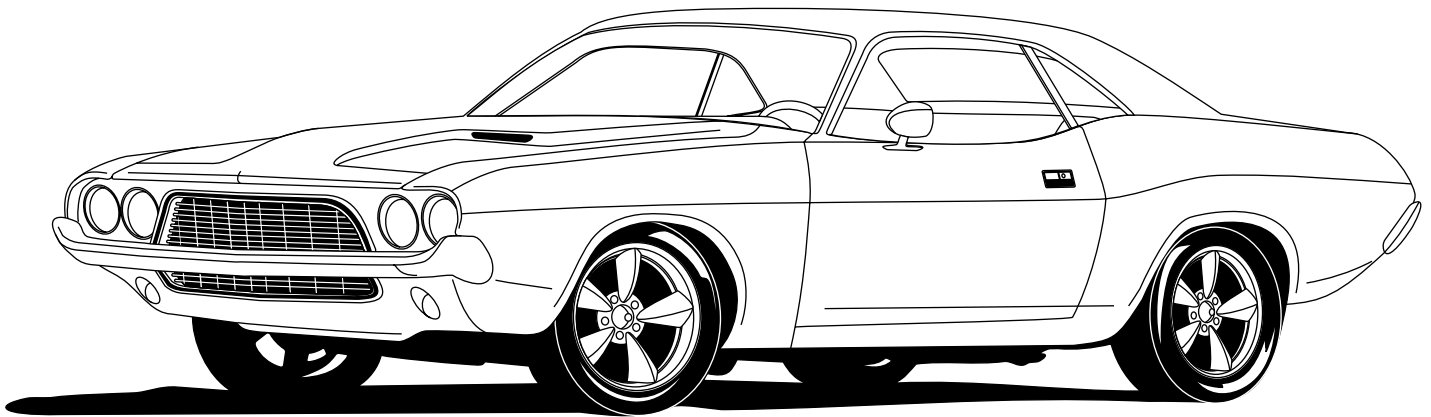

an ISO 9001:2015 Registered Company

# 1970-74 Challenger/Cuda

*with Factory Air*  
**Evaporator Kit**  
**574074-EDZ**



18865 Goll St. San Antonio, TX 78266  
Phone: 800-862-6658  
Sales: [sales@vintageair.com](mailto:sales@vintageair.com)  
Tech Support: [tech@vintageair.com](mailto:tech@vintageair.com)  
[www.vintageair.com](http://www.vintageair.com)



# Table of Contents

1. Cover
2. Table of Contents
3. Packing List/Parts Disclaimer
4. Information Page
5. Wiring Notice
6. Engine Compartment  
*Figure 1*
7. Condenser, Compressor Bracket, & Passenger Compartment  
*Figures 2 & 3*
8. Passenger Compartment (Cont.)  
*Figures 4 & 5*
9. Fresh Air Cap & A/C Duct Hose Adapter Installation  
*Figures 6, 7, & 8*
10. Evaporator Installation  
*Figure 9*
11. Evaporator Installation (Cont.)  
*Figures 10, 10a, & 10b*
12. Firewall Cover Installation  
*Figure 11*
13. Drain Hose Installation  
*Figures 12 & 12a*
14. A/C & Heater Hose Installation
15. A/C Hose Routing  
*Figures 13 & 13a*
16. Heater Control Valve Installation  
*Figure 14*
17. Control Panel Wiring & Duct Hose Routing  
*Figure 15*
18. Evaporator Hardline & Bracket Installation  
*Figure 16*
19. Wiring Diagram
20. Gen IV Wiring Connection Instructions
21. Operation Of Controls
22. Troubleshooting Information
23. Troubleshooting Information (Cont.)
24. Evaporator Kit Packing List



## Packing List Evaporator Kit (574074-EDZ)

No.	Qty.	Part No.	Description
1.	1	744004-VUE	Gen IV 4-Vent Evap. Sub Case
2.	1	784074-PMF	1970-74 Challenger/Cuda with A/C Accessory Kit

**\*\* Before beginning installation, open all packages and check contents of shipment. Please report any shortages directly to Vintage Air within 15 days. After 15 days, Vintage Air will not be responsible for missing or damaged items.**

1

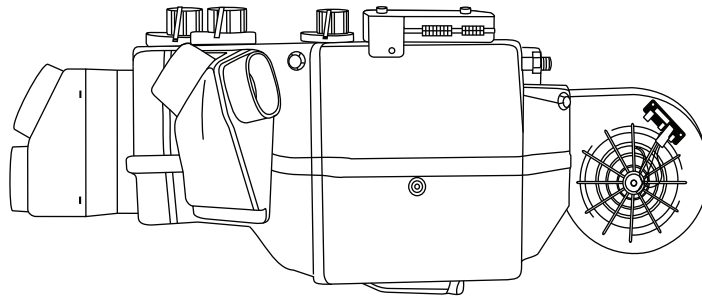

**Gen IV 4-Vent  
Evap. Sub Case  
744004-VUE**

2

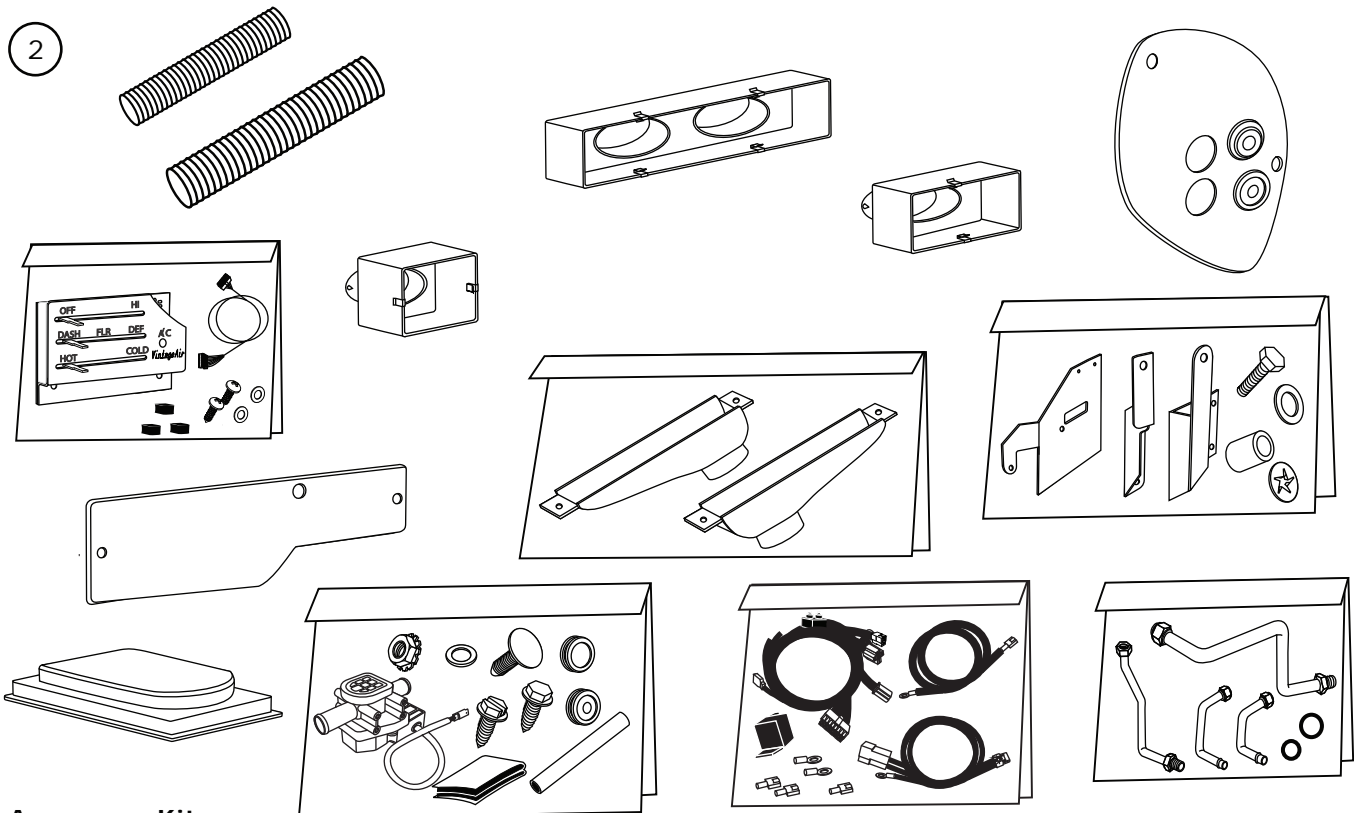

**Accessory Kit  
784074-PMF**

**Note: Images may not depict actual parts and quantities.  
Refer to packing list for actual parts and quantities.**

3



## Important Notice—Please Read

*For Maximum System Performance, Vintage Air Recommends the Following:*

**NOTE:** Vintage Air systems are designed to operate with R134a refrigerant only. Use of any other refrigerant could damage your A/C system and/or vehicle, and possibly cause a fire, in addition to potentially voiding the warranties of the A/C system and its components.

### Refrigerant Capacities:

**Vintage Air System:** 1.8 lbs. (1 lb., 12 oz.) of **R134a**, charged by weight with a quality charging station or scale. **NOTE:** Use of the proper type and amount of refrigerant is critical to system operation and performance.

**Other Systems:** Consult manufacturer's guidelines.

### Lubricant Capacities:

**New Vintage Air-supplied Sanden Compressor:** No additional oil needed (Compressor is shipped with proper oil charge).

**All Other Compressors:** Consult manufacturer (Some compressors are shipped dry and will need oil added).

### Safety Switches

Your Vintage Air system is equipped with a binary pressure safety switch. A binary switch disengages the compressor clutch in cases of extreme low pressure conditions (Refrigerant Loss) or excessively high head pressure (406 PSI) to prevent compressor damage or hose rupture. A trinary switch combines Hi/Lo pressure protection with an electric fan operation signal at 254 PSI, and should be substituted for use with electric fans. Compressor safety switches are extremely important since an A/C system relies on refrigerant to circulate lubricant.

### Service Info:

**Protect Your Investment:** Prior to assembly, it is critical that the compressor, evaporator, A/C hoses and fittings, hardlines, condenser and receiver/drier remained capped. Removing caps prior to assembly will allow moisture, insects and debris into the components, possibly leading to reduced performance and/or premature failure of your A/C system. This is especially important with the receiver/drier.

Additionally, when caps are removed for assembly, **BE CAREFUL!** Some components are shipped under pressure with dry nitrogen.

**Evacuate the System for 35-45 Minutes:** Ensure that system components (Drier, compressor, evaporator and condenser) are at a temperature of at least 85° F. On a cool day, the components can be heated with a heat gun **or** by running the engine with the heater on before evacuating. Leak check and charge to specifications.

### Bolts Passing Through Cowl and/or Firewall:

To ensure a watertight seal between the passenger compartment and the vehicle exterior, for all bolts passing through the cowl and/or firewall, Vintage Air recommends coating the threads with silicone prior to installation.

### Heater Hose (Not Included With This Kit):

Heater hose may be purchased from Vintage Air (Part# 31800-VUD) or your local parts retailer. Routing and required length will vary based on installer preference.



## Important Wiring Notice—Please Read

*Some Vehicles May Have Had Some or All of Their Radio Interference Capacitors Removed. There Should Be a Capacitor Found At Each of the Following Locations:*

- 1. On the positive terminal of the ignition coil.**
- 2. If there is a generator, on the armature terminal of the generator.**
- 3. If there is a generator, on the battery terminal of the voltage regulator.**

Most alternators have a capacitor installed internally to eliminate what is called “whining” as the engine is revved. If whining is heard in the radio, or just to be extra cautious, a radio interference capacitor can be added to the battery terminal of the alternator.

It is also important that the battery lead is in good shape and that the ground leads are not compromised. There should be a heavy ground from the battery to the engine block, and additional grounds to the body and chassis.

If these precautions are not observed, it is possible for voltage spikes to be present on the battery leads. These spikes come from ignition systems, charging systems, and from switching some of the vehicle’s other systems on and off. Modern computer-operated equipment can be sensitive to voltage spikes on the power leads, which can cause unexpected resets, strange behavior, and/or permanent damage.

Vintage Air strives to harden our products against these types of electrical noise, but there is a point where a vehicle’s electrical system can be degraded so much that nothing can help.

Radio interference capacitors should be available at most auto and truck parts suppliers. They typically are cylindrical in shape, a little over an inch long, a little over a half inch in diameter, and they have a single lead coming from one end of the cylinder with a terminal on the end of the wire, as well as a mounting clip which is screwed into a good ground on the vehicle. The specific value of the capacitance is not too significant in comparison to ignition capacitors that are matched with the coil to reduce pitting of the points.

- Care must be taken, when installing the compressor lead, not to short it to ground. The compressor lead must not be connected to a condenser fan or to any other auxiliary device. Shorting to ground or connecting to a condenser fan or any other auxiliary device may damage wiring, the compressor relay, and/or cause a malfunction.
- When installing ground leads on Gen IV systems, the blower control ground and ECU ground must be connected directly to the negative battery post.
- For proper system operation, the heater control valve must be connected to the ECU.



## Engine Compartment

**NOTE:** Before starting the air conditioner installation, check all components (radio, lights, wipers, etc.) for proper operation, and study the instructions, illustrations and diagrams.

1. Disconnect battery.
2. Drain radiator.
3. Evacuate the A/C system if necessary.
4. Remove hood latch assembly.
5. Remove OEM condenser and drier.
6. Remove OEM A/C lines from compressor to evaporator.
7. Remove OEM A/C compressor and compressor bracket.
8. Remove OEM blower assembly.
9. Remove OEM evaporator.

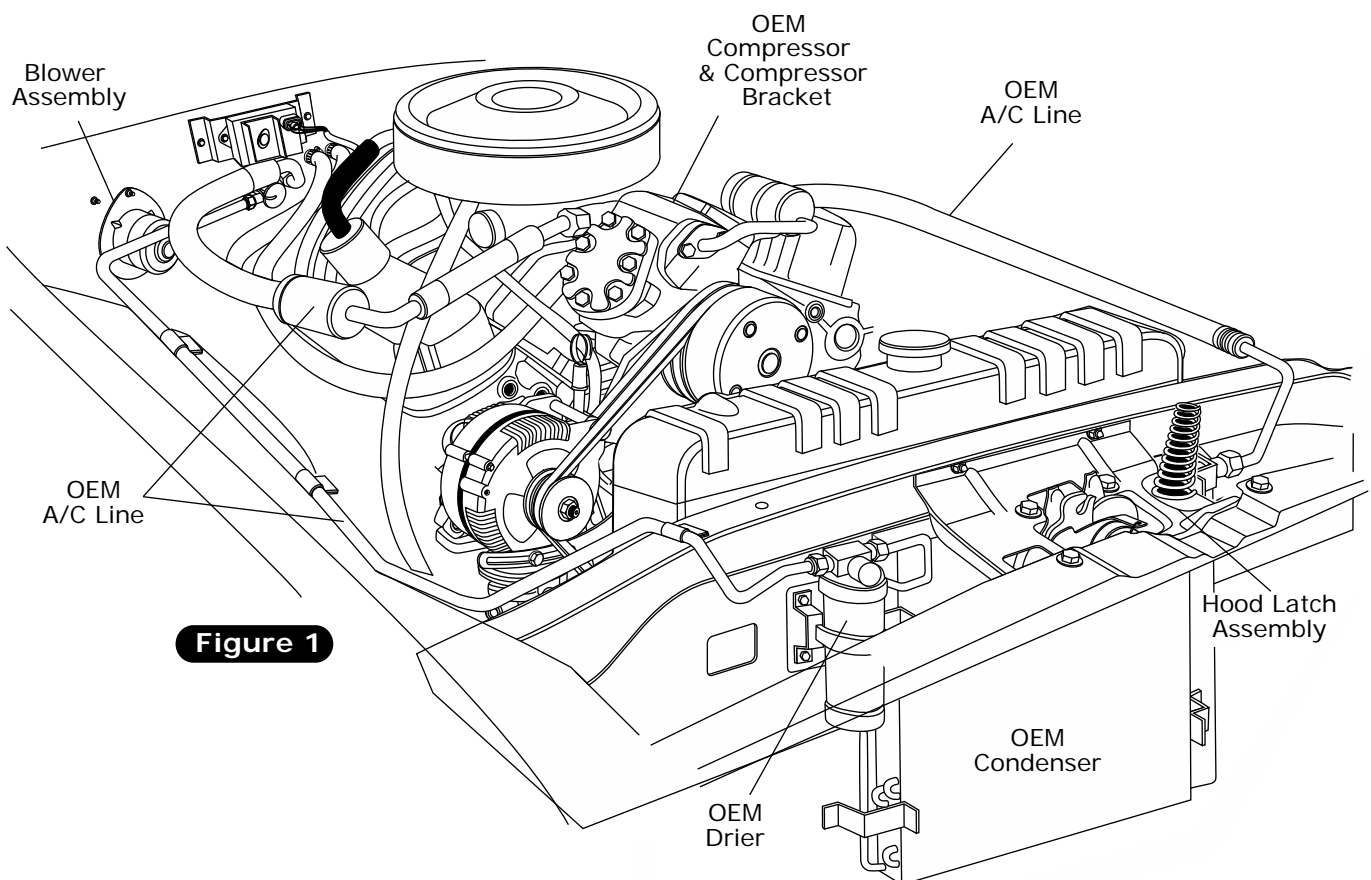
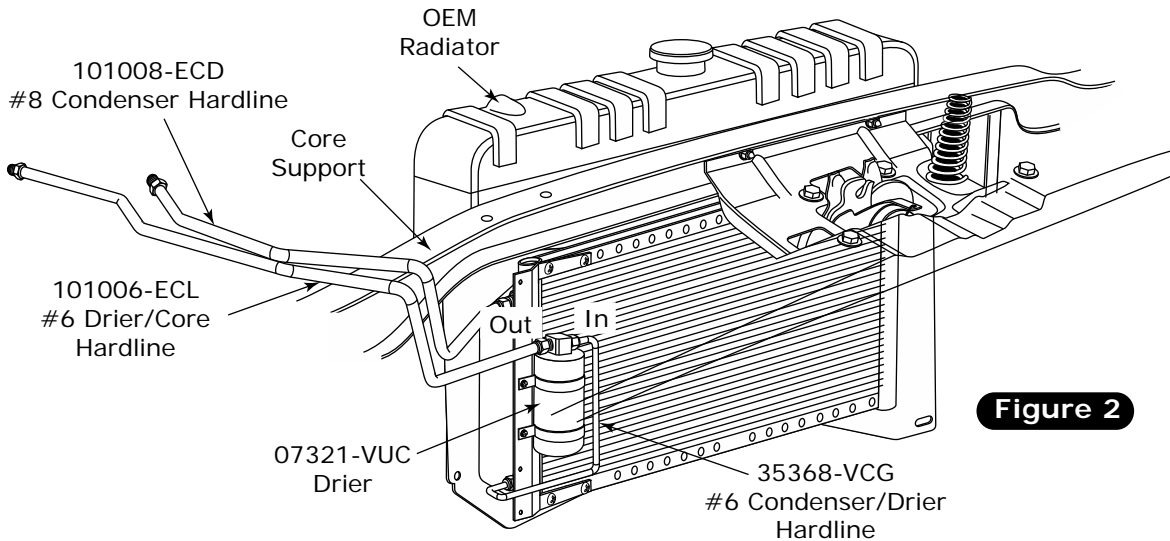

**Figure 1**



## Condenser Assembly & Installation

1. Refer to separate instructions included with the condenser kit to install the condenser. Refer to Figure 2, below, for condenser location.



**Figure 2**

## Compressor & Brackets

1. Refer to separate instructions included with the bracket kit to install the compressor bracket.

## Passenger Compartment

1. To ease installation, loosen the top (4) dash mounting bolts located in defrost ducts along the bottom side of the windshield, and the (2) side dash mounting bolts.
2. Pull dash away from windshield to remove (4) OEM defrost duct mounting screws (See Figure 3, below).
3. Remove passenger side OEM A/C duct assembly (See Figure 3, below).
4. Remove driver side OEM A/C duct assembly (See Figure 3, below).
5. Remove OEM defrost duct assembly (See Figure 3, below).

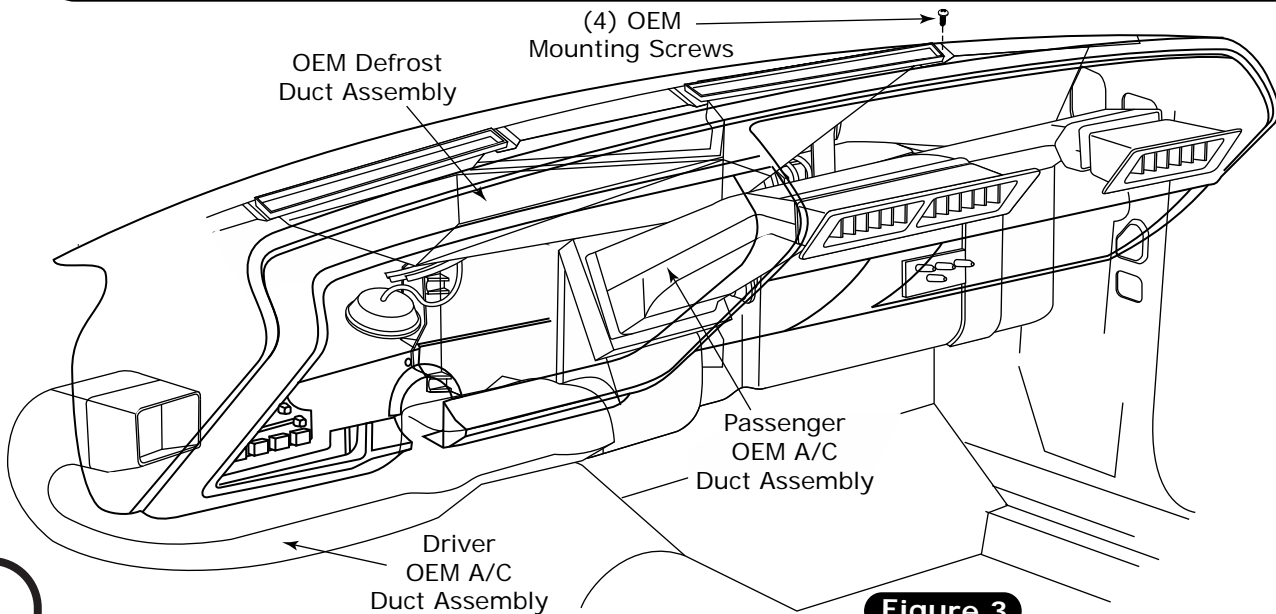
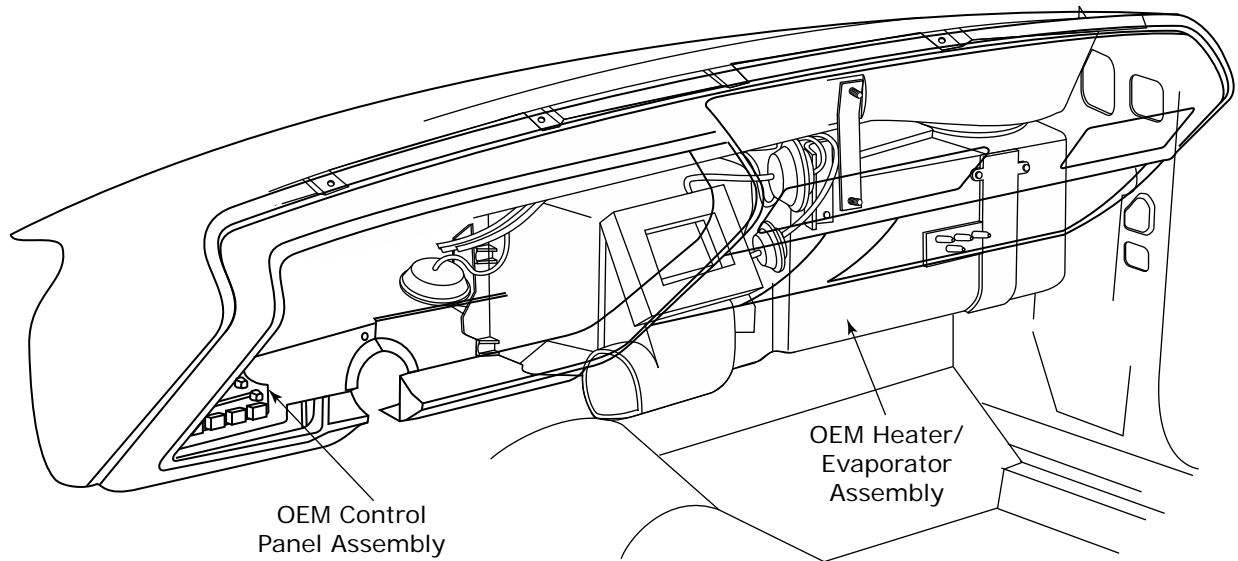

**Figure 3**



## Passenger Compartment (Cont.)

1. Remove the OEM heater/evaporator assembly from under dash as shown in Figure 4, below.
2. Remove the OEM control panel assembly from dash as shown in Figure 4, below.
3. Refer to control panel conversion kit instructions for installation of controls.



**Figure 4**

## Defrost Duct Installation

1. Using the OEM mounting screw, install the new defrost ducts as shown in Figure 5, below.

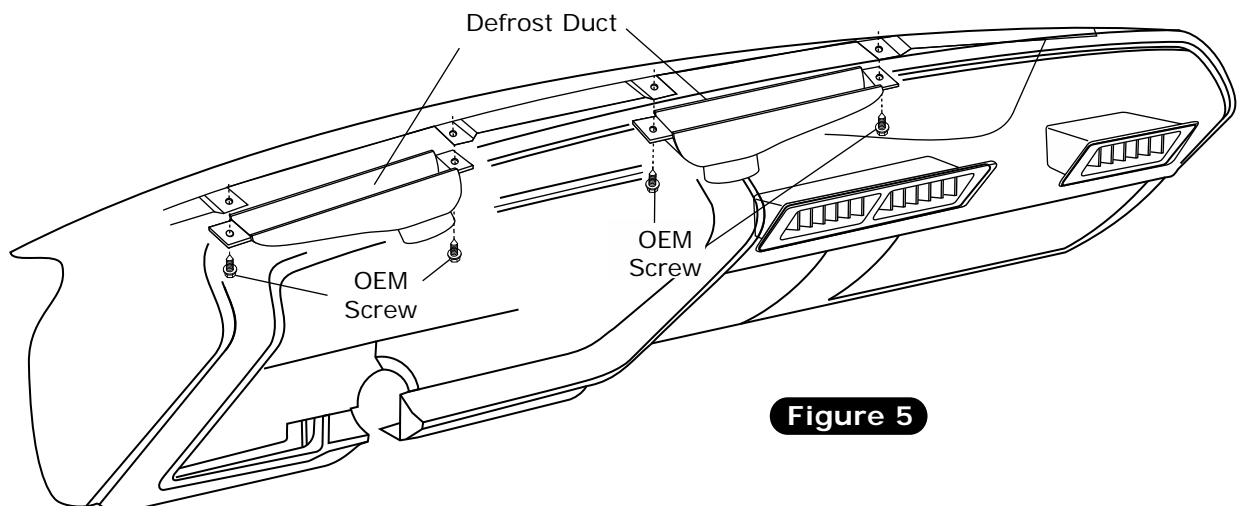

**Figure 5**





## Fresh Air Cap Installation

1. Using (2) #10 x 1/2" sheet metal screws, install the fresh air cap as shown in Figure 6, below.

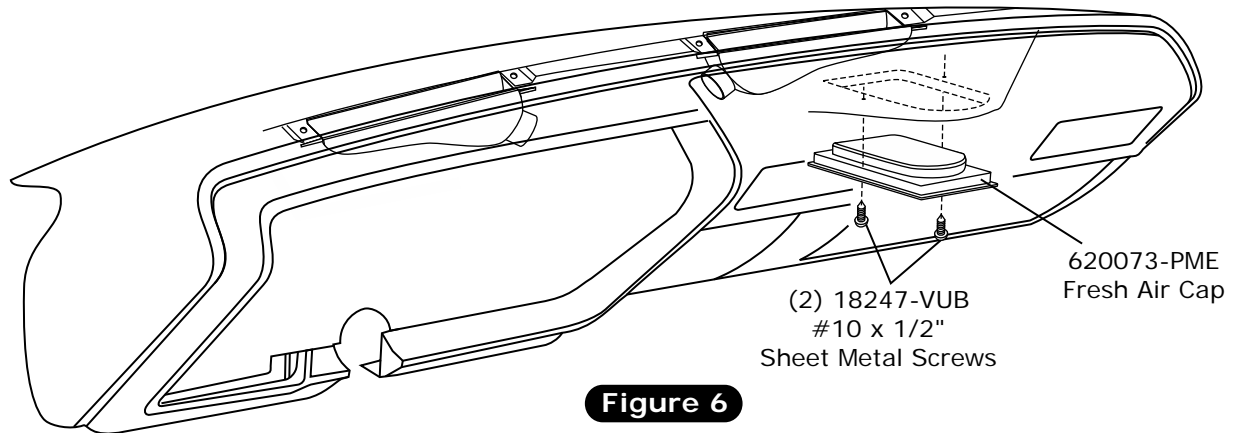

## Passenger and Driver Side A/C Duct Hose Adapter Installation

1. Install the A/C duct hose adapters as shown in Figure 7, below.
2. Install the driver side louver hose adapter on control panel assembly as shown in Figure 8, below.

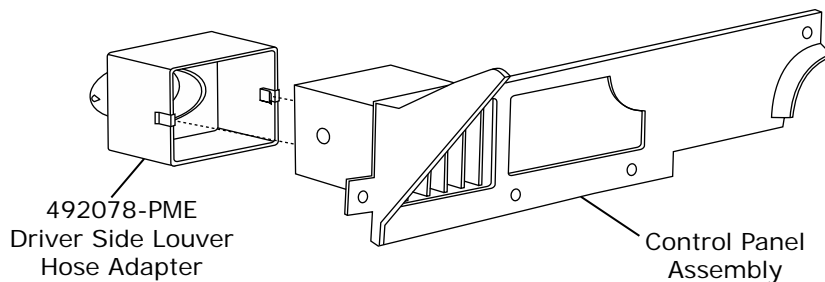
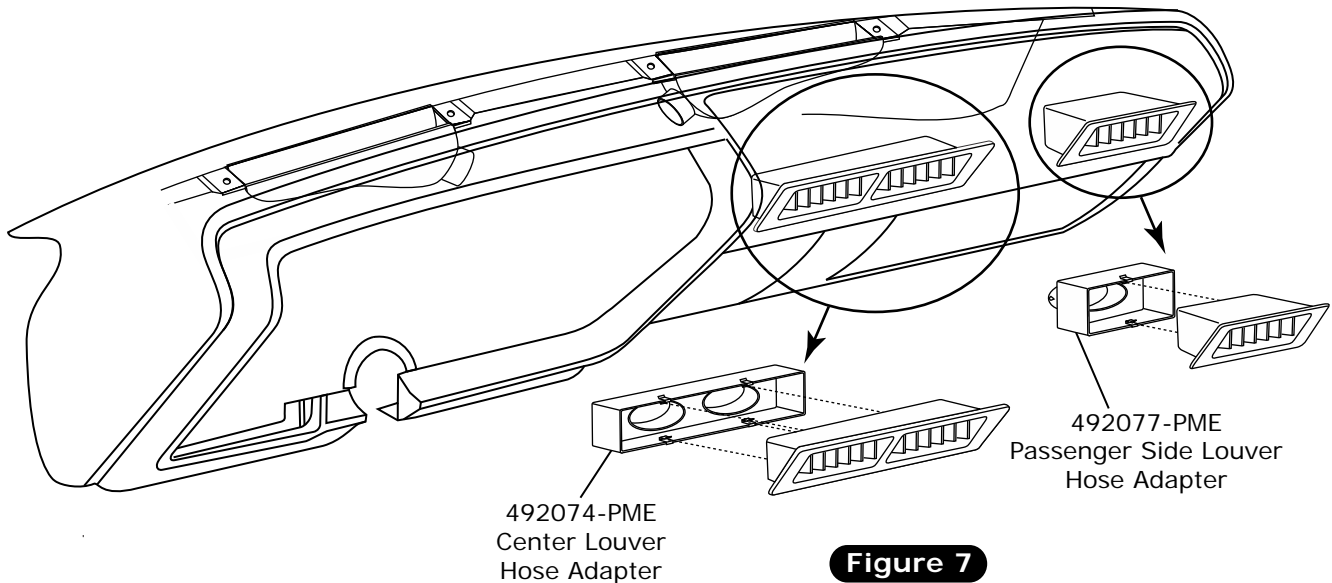



## Evaporator Installation

1. Mark front evaporator mounting bracket hole locations on inner cowl (See Figure 10a, Page 11). Once holes are marked in the correct location, drill 1/8" holes in inner cowl for front evaporator bracket mounting location.
2. Mark and drill (2) 9/32" holes for driver/passenger side evaporator rear mounting bracket in firewall (See Figure 10b, Page 11).
3. On a workbench, install evaporator rear bracket and hardlines with properly lubricated O-rings (See Figure 13a, Page 15, and Figure 16, Page 18).
4. Install front mounting bracket on evaporator using (2) 1/4-20 x 1/2" hex bolts, and tighten as shown in Figure 9, below.
5. Lift evaporator unit up under the dashboard (See Figure 10, Page 11). Secure loosely to the firewall from the engine compartment side using (2) 1/4-20 nuts and washers (See Figure 10, Page 11).
6. Using (2) #14 x 3/4" sheet metal screws, secure the front evaporator mounting bracket to the inner cowl (See Figure 10, Page 11).
7. Verify that evaporator unit is level and square to the dash. Then tighten all mounting bolts. **NOTE: Tighten the bolt on the firewall first. Then tighten the front mounting bracket screws.**

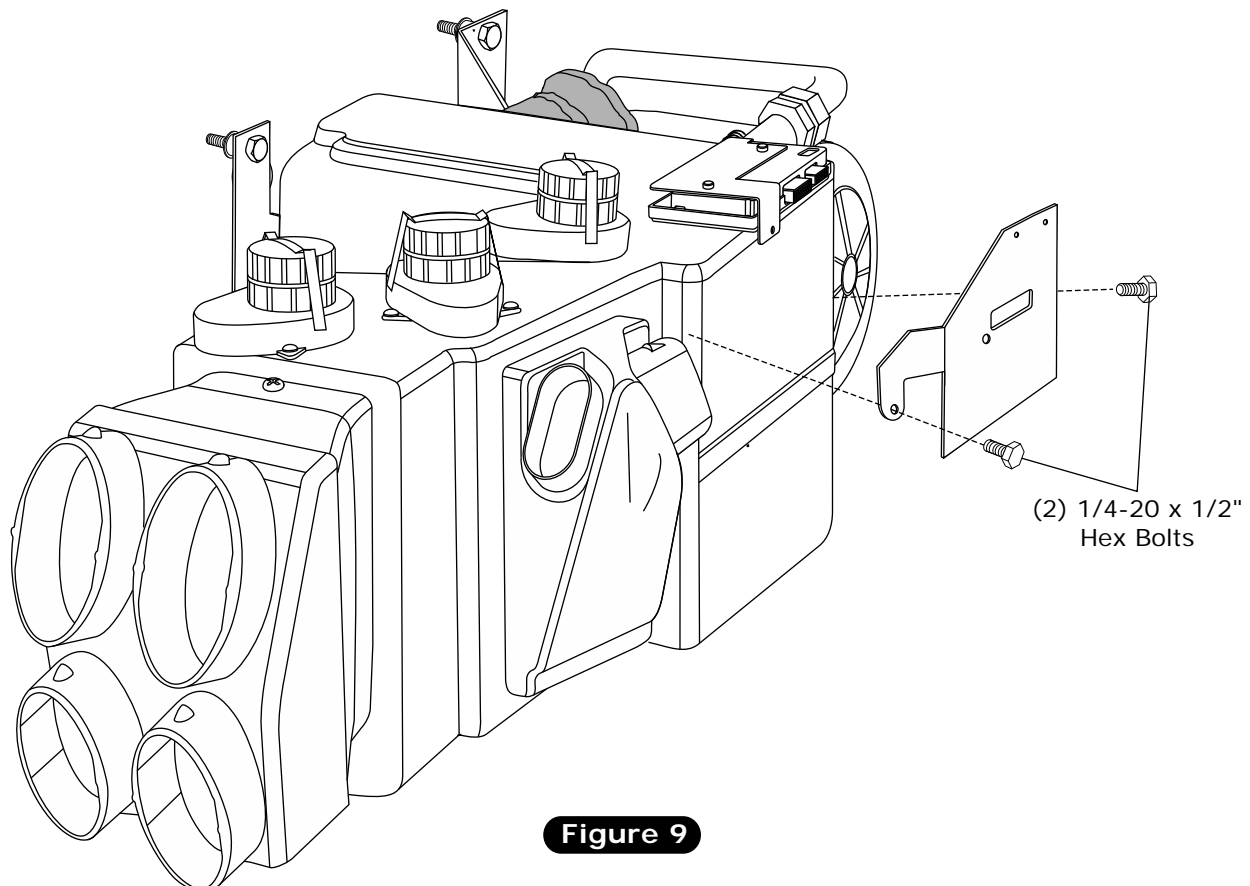
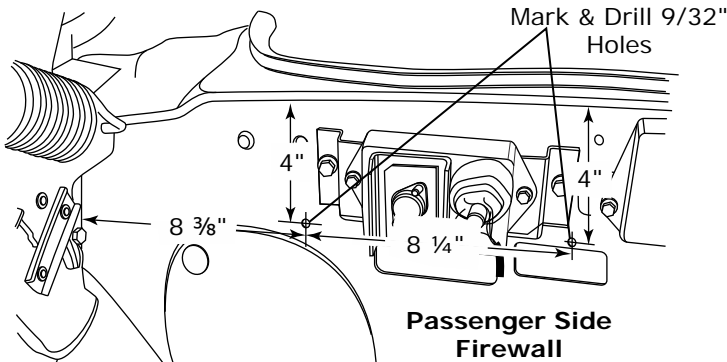
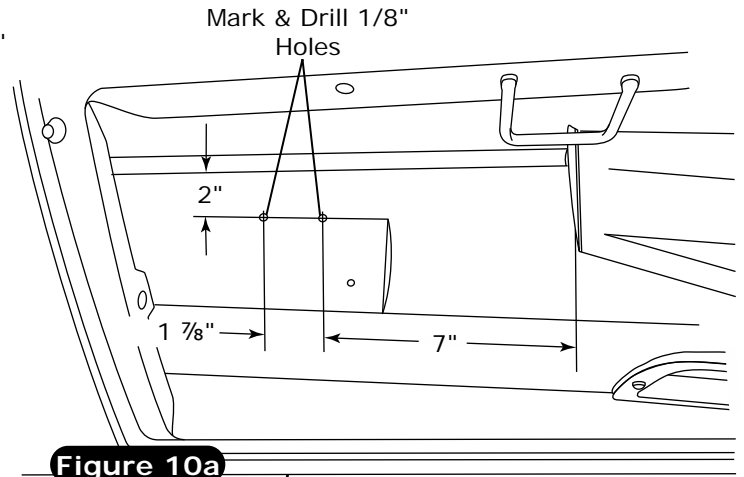

Figure 9



**Figure 10b**



**Figure 10a**

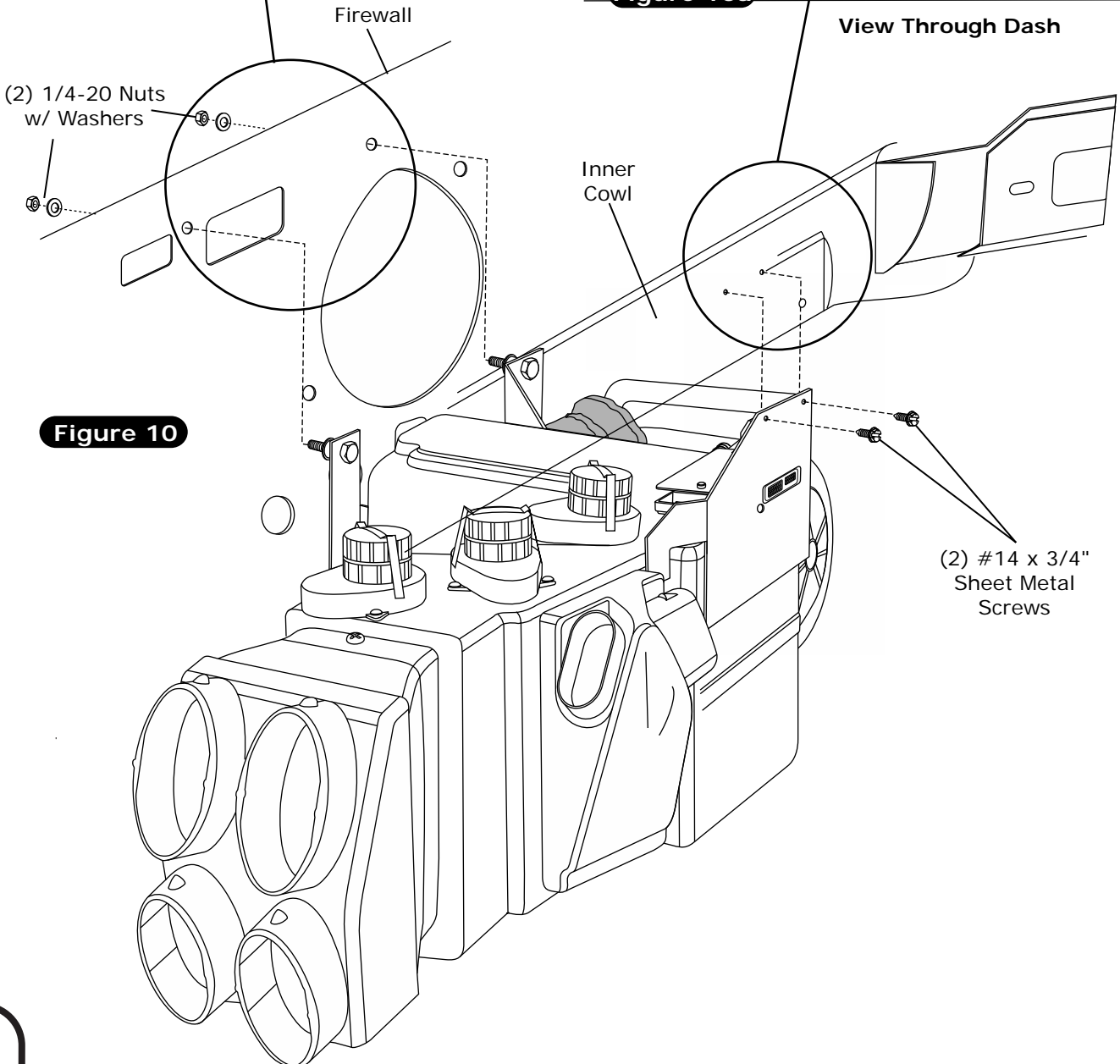

**Figure 10**

(2) #14 x 3/4"  
Sheet Metal  
Screws



## Firewall Cover Installation

1. Apply 1/4" bead of silicone around the back side of the firewall cover as shown in Figure 11, below.
2. Pass lines through firewall cover, and secure with (2) 7/16" panel retainers (See Figure 11, below).
3. Apply a 1/4" bead of silicone around the back side of the A/C block-off plate as shown in Figure 11, below.
4. Drill (2) 1/8" holes in firewall using the A/C block-off plate as a template (See Figure 11, below).
5. Install the A/C block-off plate using (2) #10 x 1/2" sheet metal screws as shown in Figure 11, below.

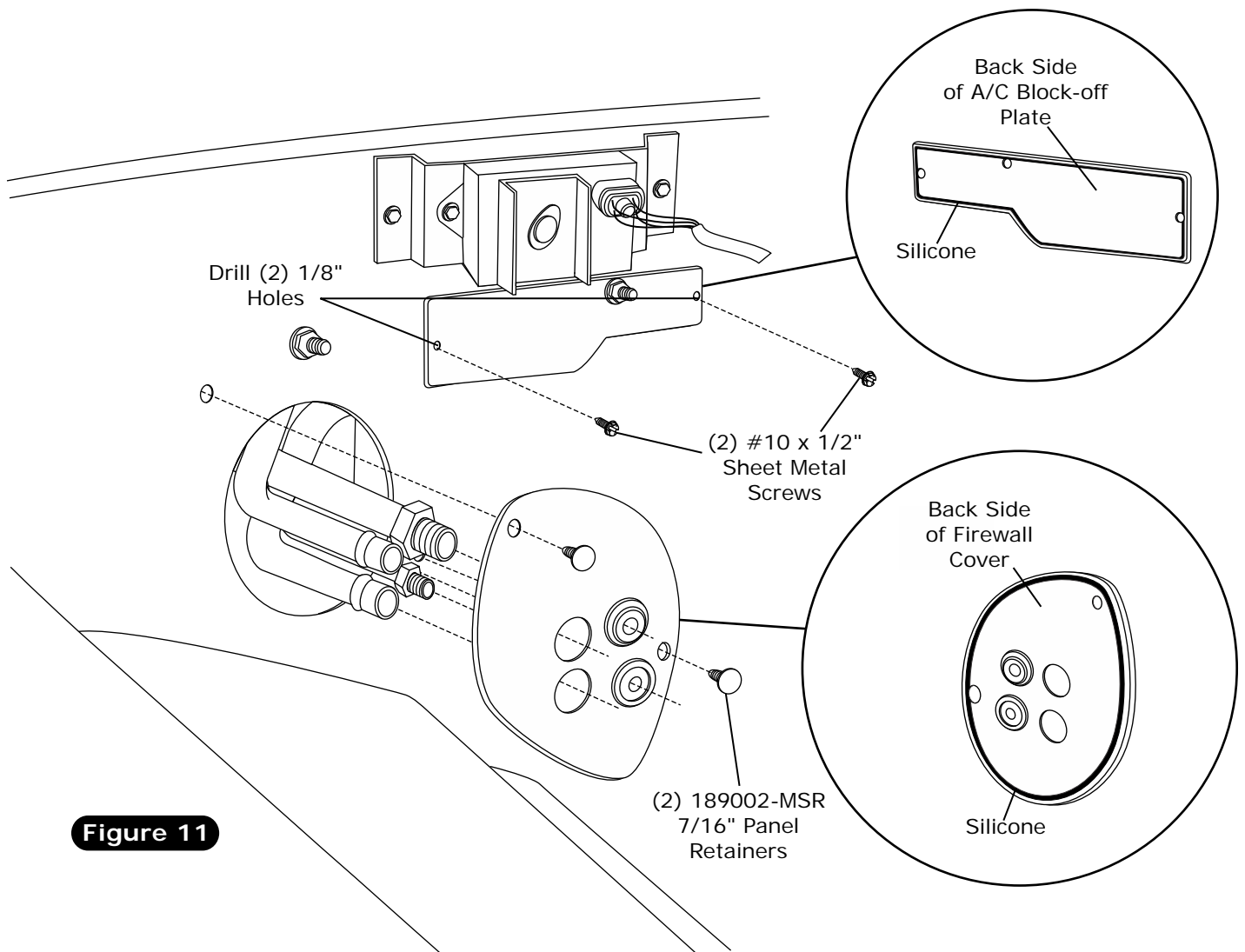

**Figure 11**



## Drain Hose Installation

1. Install grommets in OEM holes (See Figure 12, below).
2. Install drain hose to the bottom of the evaporator unit and route through the firewall (See Figure 12a, below).

**Figure 12**

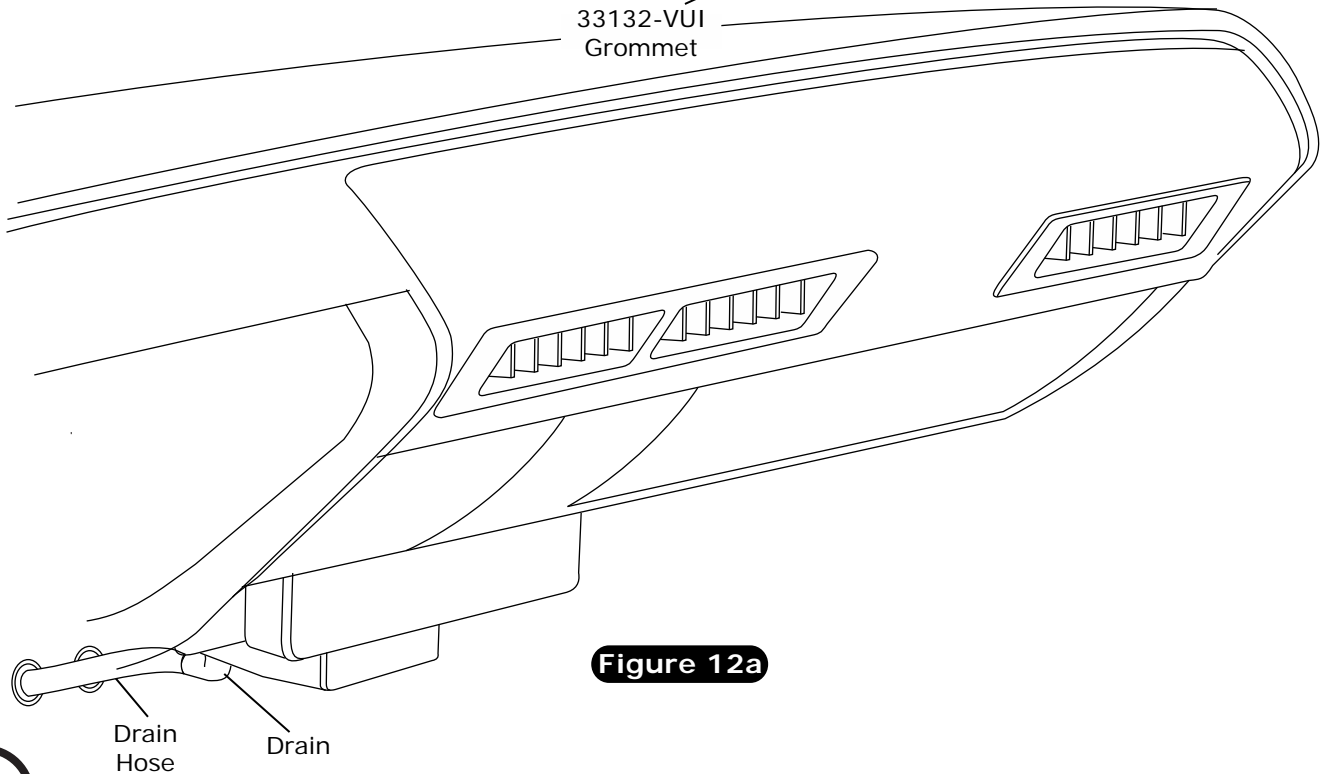
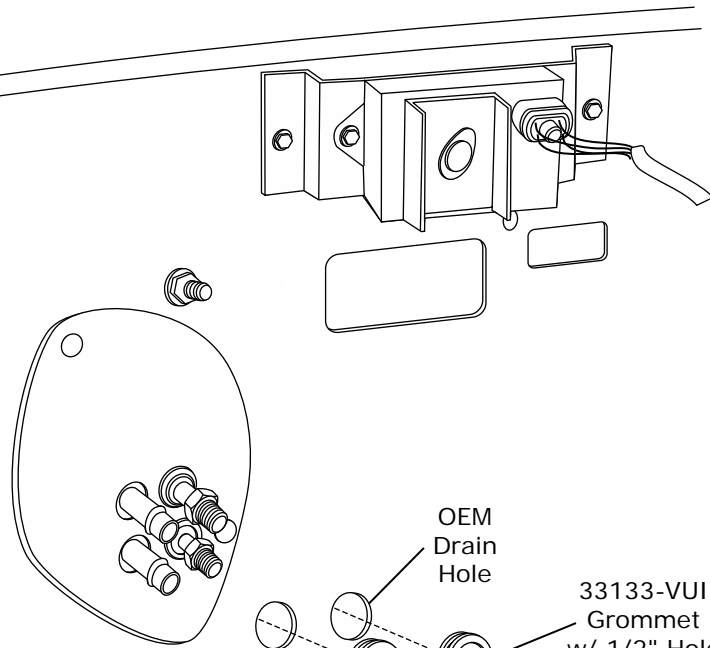

**Figure 12a**



## A/C Hose Installation

1. Locate the #10 compressor A/C hose. Lubricate (2) #10 O-rings (See Figure 10a, Page 14) and connect the 90° fitting to the #10 suction port on the compressor, and then route the straight fitting to the #10 evaporator hardline coming through the firewall (See Figure 10, Page 14). Tighten each fitting connection as shown in Figure 10a, Page 14. **NOTE: The #10 A/C hose 90° fitting at the compressor must be installed below the #8 135° hose fitting. This needs to be done so the air filter box is not pushed out of position by the #10 A/C hose. In some cases the fuel filter may block the routing of the #10 hose, if so the fuel filter will have to be relocated to clear the routing of the #10 hose. Wrap the #10 fitting connections at the firewall with press tape (See Figure 10, Page 14).**
2. Locate the #8 compressor A/C hose. Lubricate (2) #8 O-rings (See Figure 10a, Page 14) and connect the 135° fitting to the #8 discharge port on the compressor, and then route the 45° fitting to the #8 condenser hardline on the fender well (See Figure 10, Page 14). Tighten each fitting connection as shown in Figure 10a, Page 14.
3. Locate the #6 evaporator/core hardline. Lubricate (2) #6 O-rings (See Figure 10a, Page 14) and connect the hardline to the #6 drier/core hardline on the fender well from the drier. Attach the other end of the hardline with lubricated O-ring to the #6 evaporator hardline coming through the firewall (See Figure 10, Page 14). Tighten each fitting connection as shown in Figure 10a, Page 14. Use a #2 Adel clamp to secure the #6 evaporator/core hardline to the inner fender well as shown in Figure 10, Page 14. Secure the Adel clamp to the inner fender using a #10 x 1/2" sheet metal screw.

## Modified A/C Hose Kit

1. Refer to separate instructions included with modified hose kit.

## Heater Hose & Heater Control Valve Installation

1. Route a piece of heater hose from the water pump to the heater line coming through the firewall as shown in Figure 13, Page 15, and Figure 14, Page 16. Secure using hose clamps.
2. Route a piece of heater hose from the intake to the heater line coming through the firewall as shown in Figure 13, Page 15, and Figure 14, Page 16. **NOTE: Install heater control valve in line with intake manifold (pressure side) heater hose. Secure using hose clamps as shown in Figure 14, Page 16. Also note proper flow direction.**

# Hose Routing

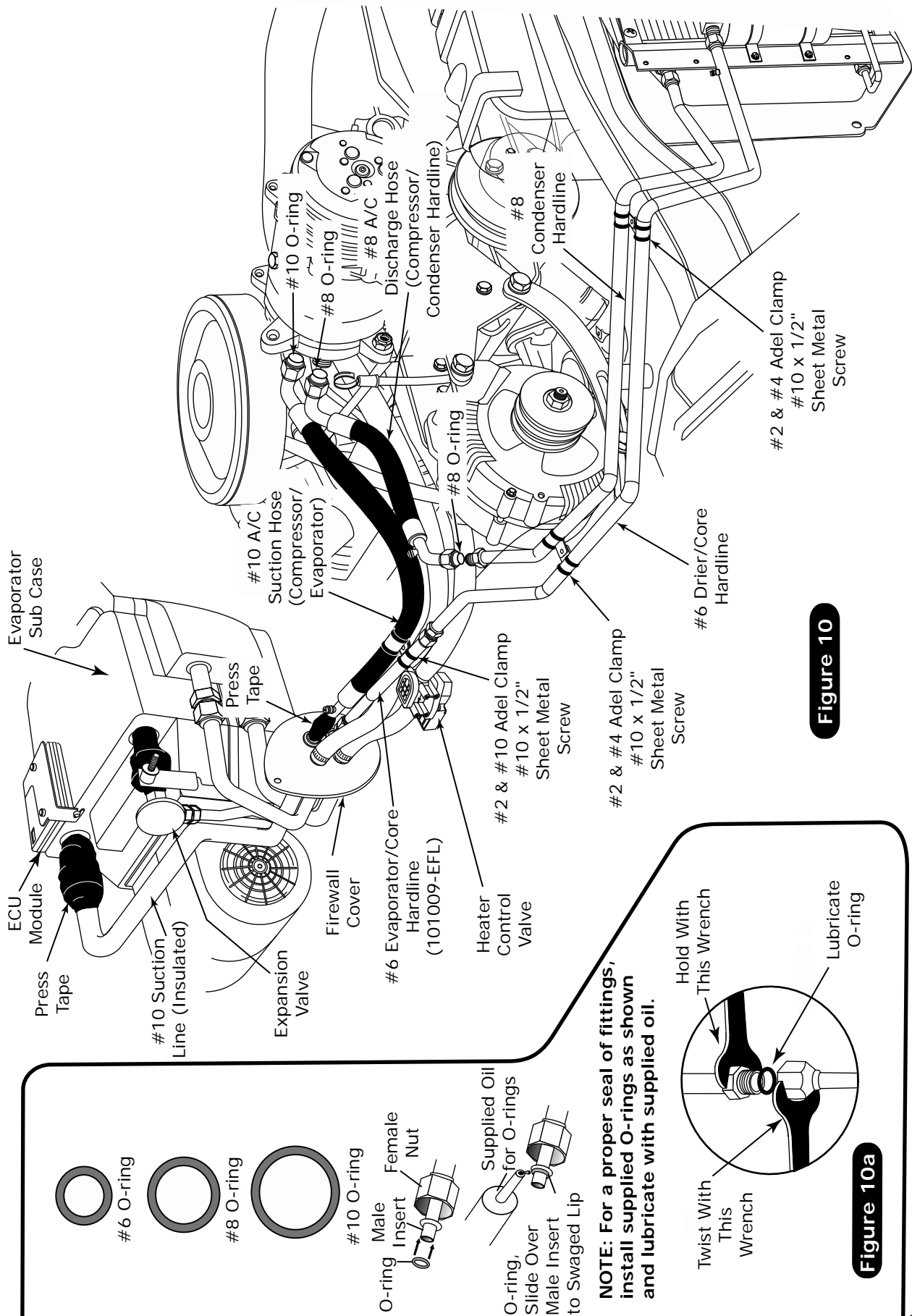

**Figure 10**

**Figure 10a**

**NOTE: For a proper seal of fittings, install supplied O-rings as shown and lubricate with supplied oil.**



## Heater Control Valve Installation

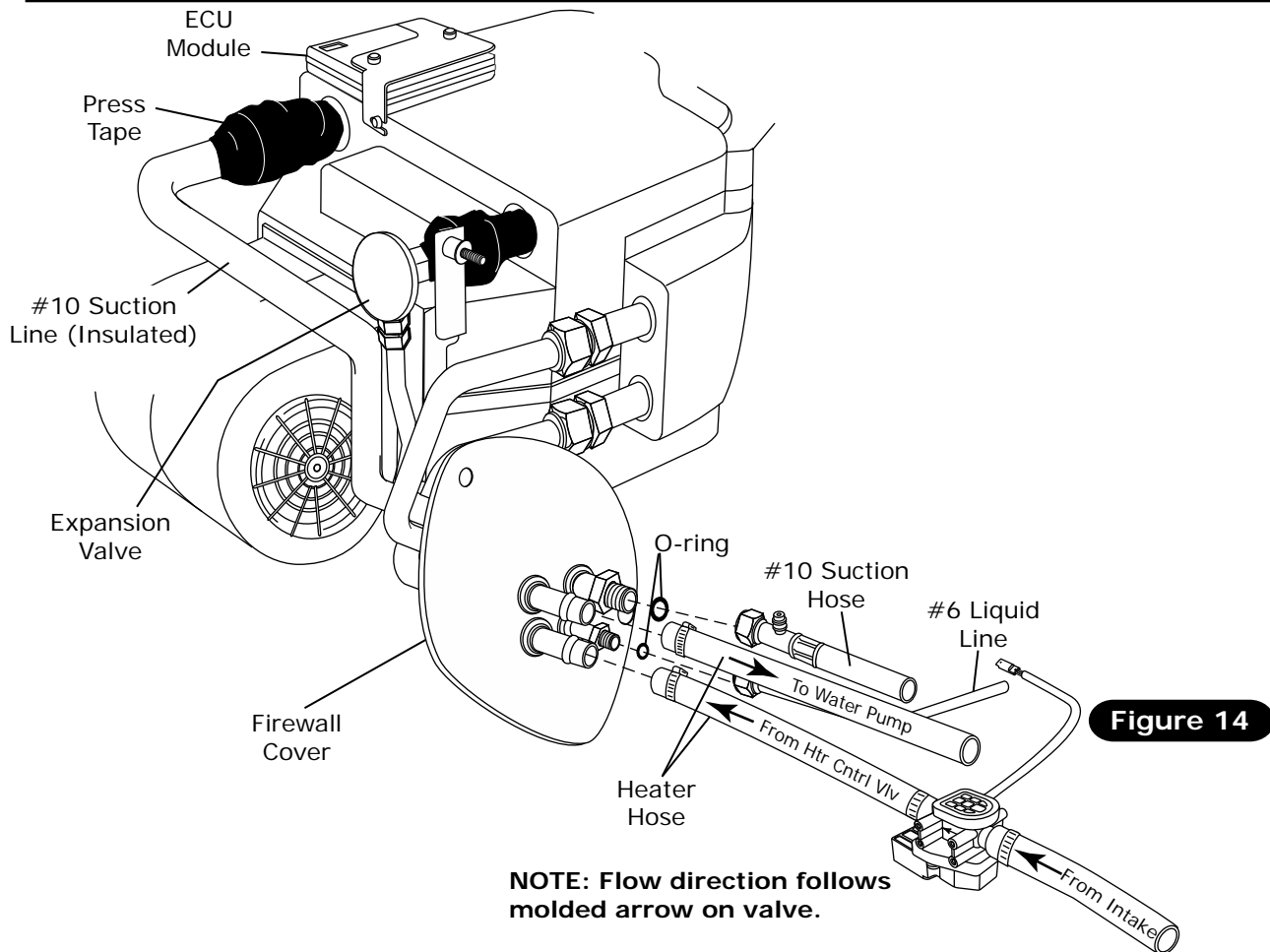

## Duct Hose Routing & Control Panel Harness

1. Install duct hoses as shown in Figure 15, Page 17.
2. Plug the control panel harness into the ECU module on the sub case as shown. See Figure 15, Page 17.
3. Route the control panel harness under the center dash assembly and connect the control harness to the PC board assembly on the back side of the control panel as shown in Figure 15, Page 17.
4. Plug the wiring harness into the ECU module on the sub case as shown (Wire according to wiring diagram on Page 19).
5. Reinstall control panel. Refer to control panel conversion kit instructions.
6. Reinstall all previously removed items (battery box & battery).
7. Fill radiator with at least a 50/50 mixture of approved antifreeze and distilled water. It is the owner's responsibility to keep the freeze protection at the proper level for the climate in which the vehicle is operated. Failure to follow antifreeze recommendations will cause heater core to corrode prematurely and possibly burst in A/C mode and/or freezing weather, voiding your warranty.
8. Double check all fittings, brackets and belts for tightness.
9. Vintage Air recommends that all A/C systems be serviced by a certified automotive air conditioning technician.
10. Evacuate the system for a minimum of 45 minutes prior to charging. Perform a leak check prior to servicing.
11. Charge the system to the capacities stated on the information page (Page 4) of this instruction manual.





## Control Panel & Duct Hose Routing

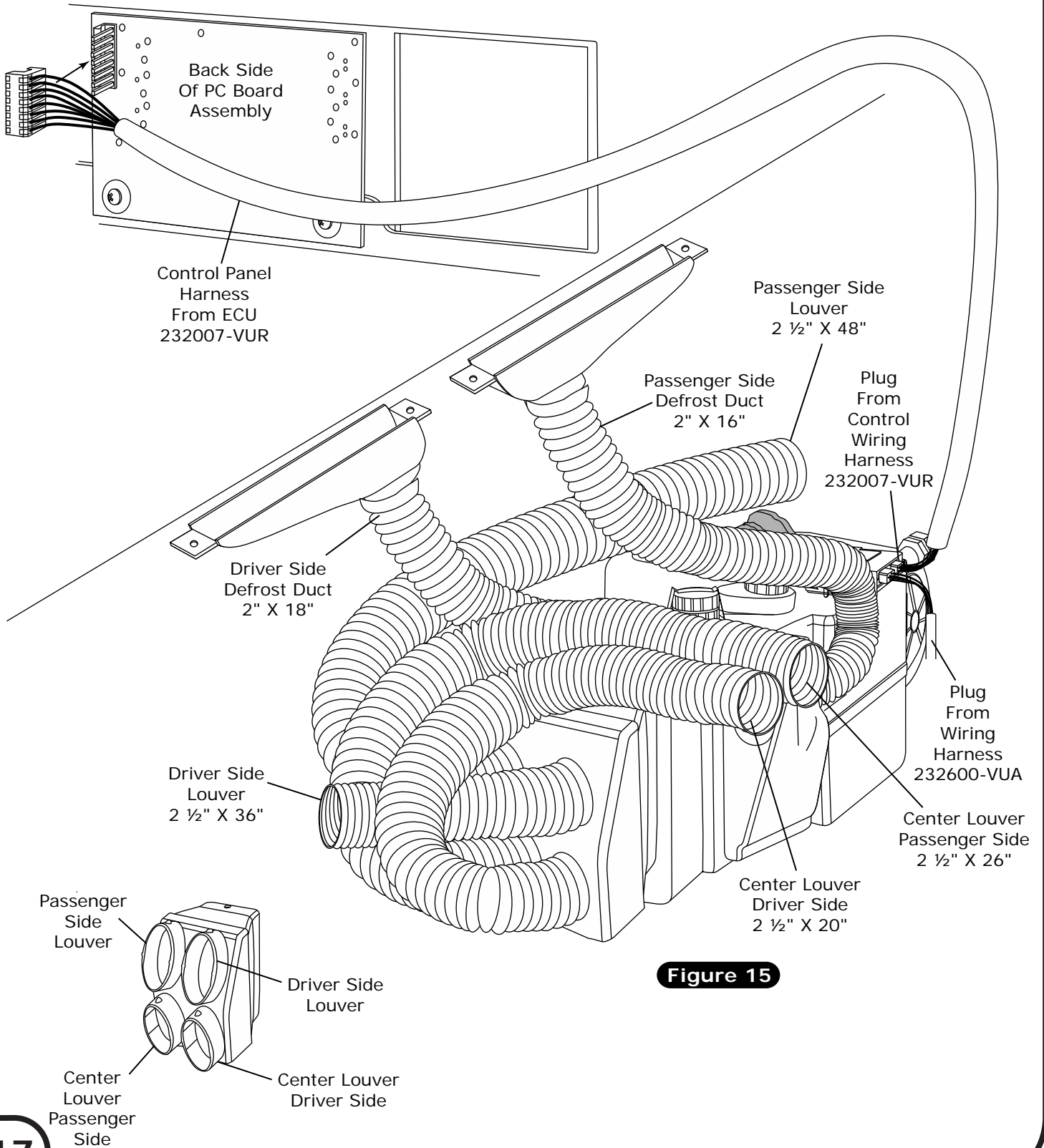

**Figure 15**



# Evaporator Hardline Installation

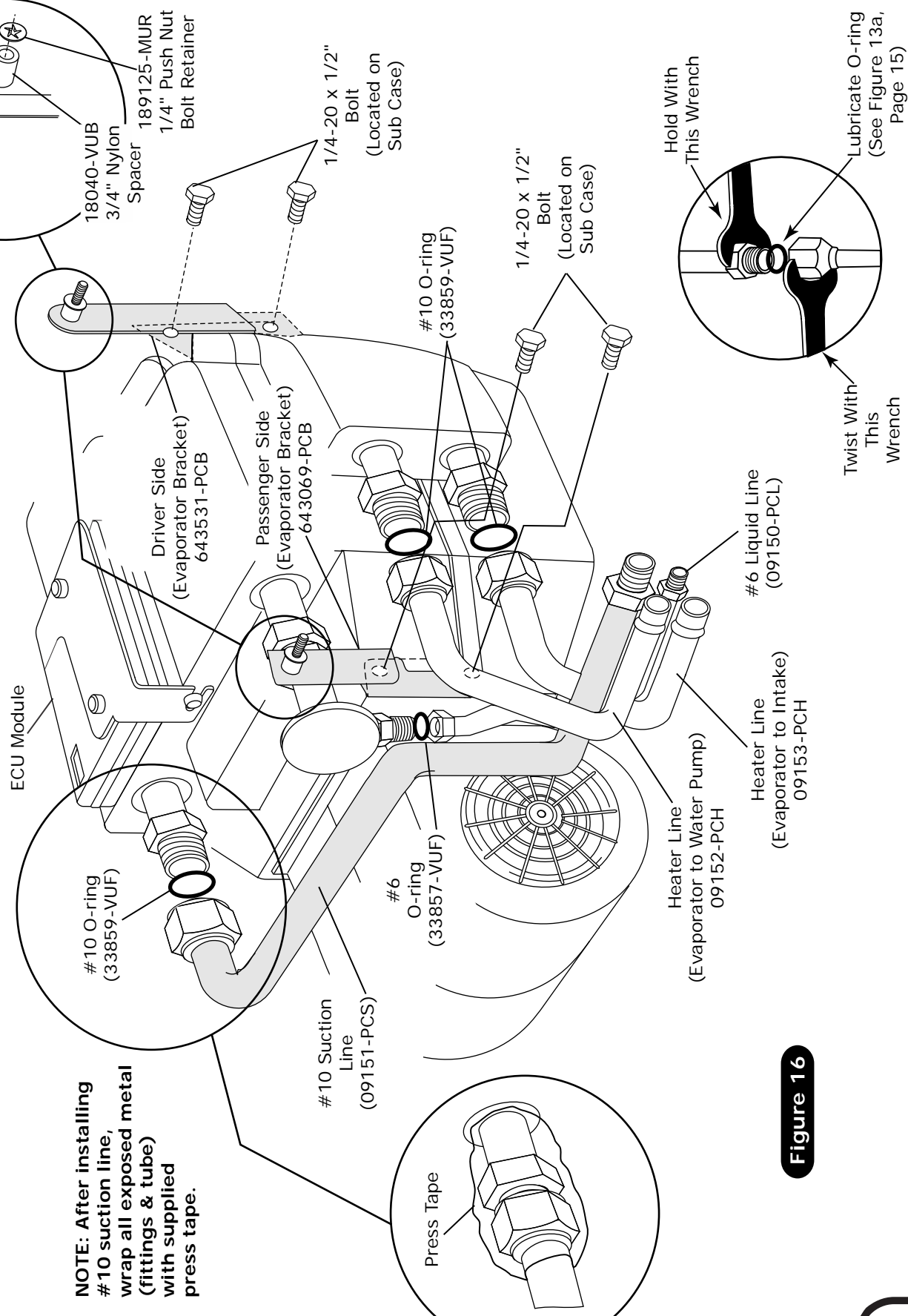

**NOTE:** After installing #10 suction line, wrap all exposed metal (fittings & tube) with supplied press tape.

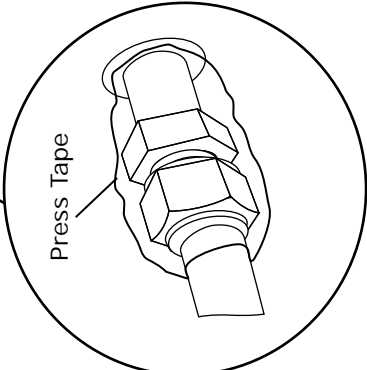
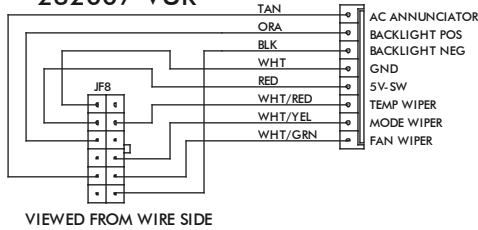

**Figure 16**



# Wiring Diagram

## 232007-VUR



## 232002-VUA

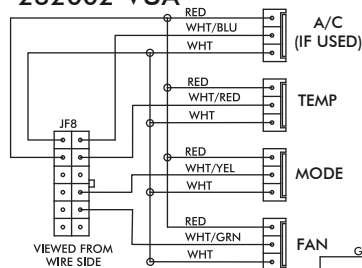

### PROGRAM

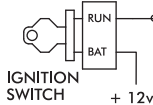
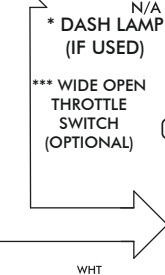

## GEN IV ECU

GEN IV WIRING DIAGRAM  
REV E, 10/6/2017

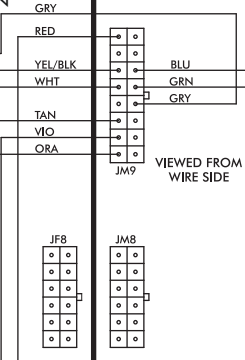

## PRE-WIRED

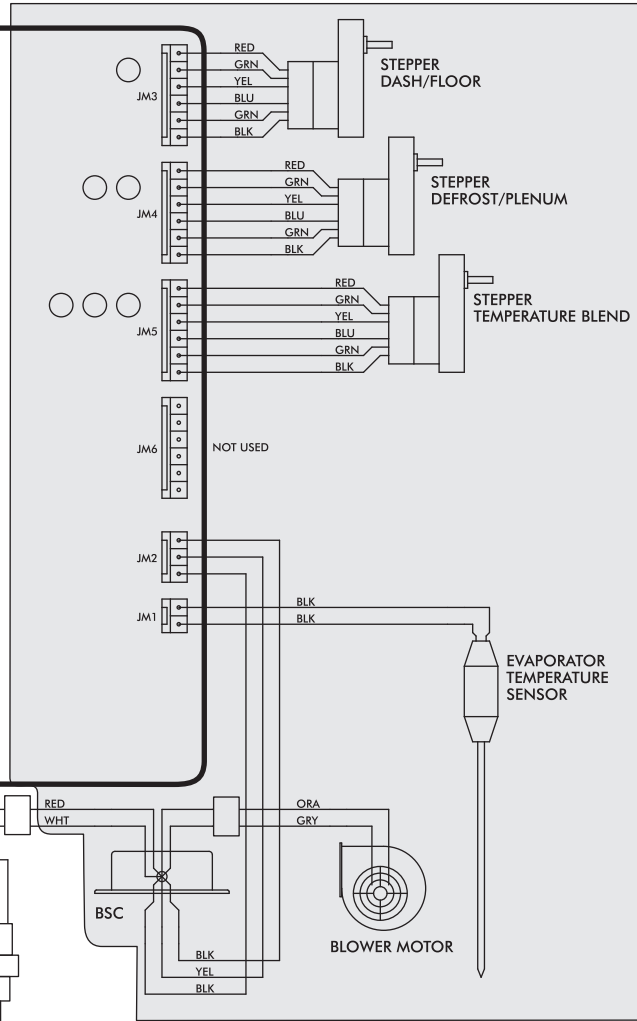

NOTE: = CHASSIS GROUND

- \* Dash Lamp Is Used Only With Type 232007-VUR Harness.
- \*\* Warning: Always Mount Circuit Breaker As Close to the Battery As Possible. (NOTE: Wire Between Battery and Circuit Breaker Is Unprotected and Should Be Carefully Routed to Avoid a Short Circuit).
- \*\*\* Wide Open Throttle Switch Contacts Close Only at Full Throttle, Which Disables A/C Compressor.



# Gen IV Wiring Connection Instruction

WIRING HARNESS

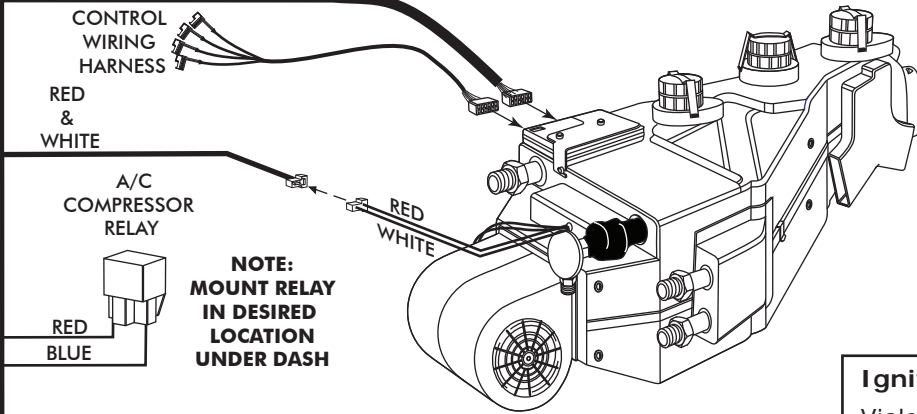

**Ignition Switch:**  
Violet 12V Ign Switch Source (Key On Accessory) Position Must Be Switched.

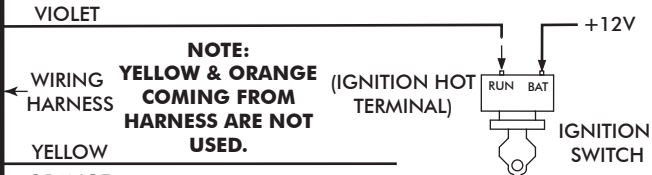

**Dash Light:**  
Tan Wire Used Only With Vintage Air Supplied Control Panel With LED Back Light.

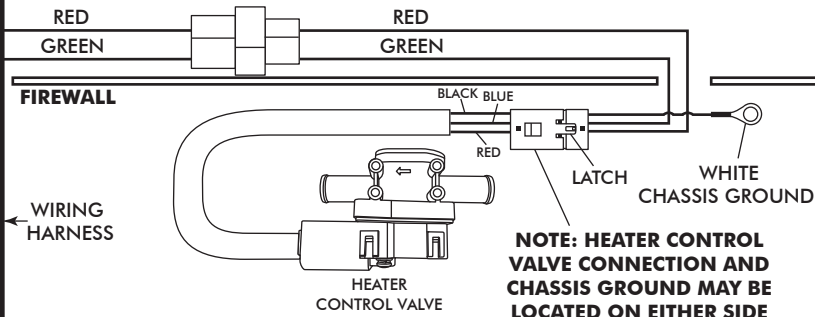
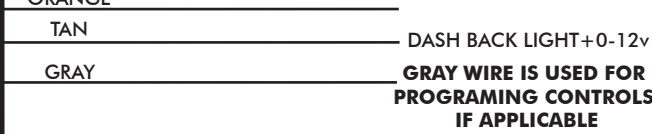

**Heater Control Valve:**  
Install With Servo Motor Facing Down, As Shown. Note Flow Direction Arrow Molded Into Valve Body, And Install Accordingly.

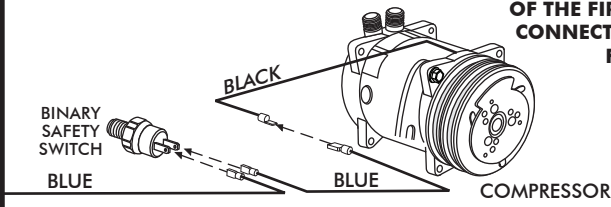

**Binary/Trinary & Compressor:**  
Binary: Connect As Shown (Typical Compressor Wiring). Be Sure Compressor Body Is Grounded.  
Trinary Switch: Connect According To Trinary Switch Wiring Diagram.

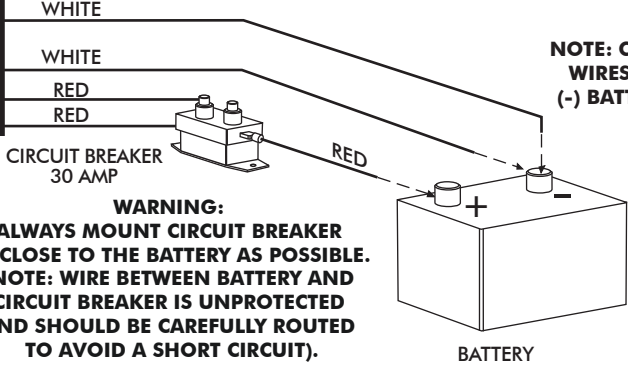

**Circuit Breaker/Battery:**  
White **Must** Run To (-) Battery. Red May Run To (+) Battery Or Starter. Mount Circuit Breaker As Close to Battery As Possible.



## Operation of Controls

On Gen IV systems with three lever/knob controls, the temperature control toggles between heat and A/C operations. To activate A/C, move the temperature lever/knob all the way to cold and then back it off to the desired vent temperature. For heat operation, move the temperature lever/knob all the way to hot and then adjust to the desired vent temperature. The blower will momentarily change speed, each time you toggle between operations, to indicate the change. **NOTE: For proper control panel function, refer to control panel instructions for calibration procedure.**

### Blower Speed

This lever/knob controls blower speed, from OFF to HI.

### Mode Control

This lever/knob controls the mode positions, from DASH to FLOOR to DEFROST, with a blend in between.

### Temperature Control

This lever/knob controls the temperature, from HOT to COLD.

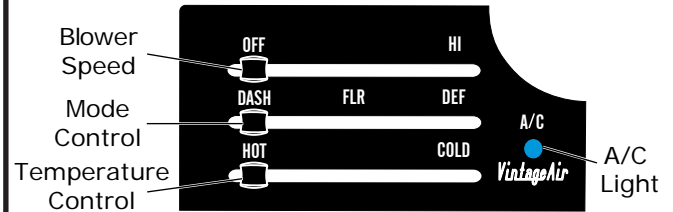

## A/C Operation

### Blower Speed

Adjust to desired speed.

### Mode Control

Adjust to desired mode position (DASH position recommended).

### Temperature Control

For A/C operation, adjust to coldest position to engage compressor (Adjust between HOT and COLD to reach desired temperature).



**NOTE: A/C operation toggles on & off when thermostat lever is moved to the HOT or COLD ends of travel. A/C mode is indicated by the blue A/C light.**

## Heat Operation

### Blower Speed

Adjust to desired speed.

### Mode Control

Adjust to desired mode position (FLOOR position recommended).

### Temperature Control

For maximum heating, adjust to hottest position (Adjust between HOT and COLD to reach desired temperature).

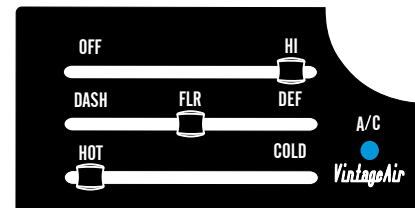

## Defrost/De-fog Operation

### Blower Speed

Adjust to desired speed.

### Mode Control

Adjust to DEFROST position for maximum defrost, or between FLOOR and DEFROST positions for a bi-level blend (Compressor is automatically engaged).

### Temperature Control

Adjust to desired temperature.

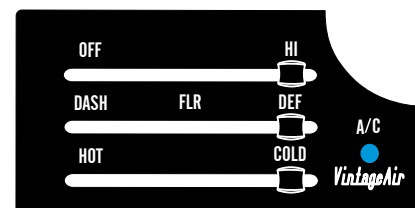



# Troubleshooting Guide

Symptom	Condition	Checks	Actions	Notes
1a. Blower stays on high speed when ignition is on.	No other functions work.	Check for damaged pins or wires in control head plug.	Verify that all pins are inserted into plug. Ensure that no pins are bent or damaged in ECU.	Loss of ground on this wire renders control head inoperable.
	All other functions work.	Check for damaged ground wire (white) in control head harness.	Verify continuity to chassis ground with white control head wire at various points.	
			Check for damaged blower switch or potentiometer and associated wiring.	
1b. Blower stays on high speed when ignition is on or off.		Unplug 3-wire BSC control connector from ECU. If blower shuts off, ECU is either improperly wired or damaged.	Be sure the small, 20 GA white ground wire is connected to the battery ground post. If it is, replace the ECU.	No other part replacements should be necessary.
		Unplug 3-wire BSC control connector from ECU. If blower stays running, BSC is either improperly wired or damaged.	Check to ensure that no BSC wiring is damaged or shorted to vehicle ground. The BSC operates the blower by ground side pulse width modulation switching. The positive wire to the blower will always be hot. If the "ground" side of the blower is shorted to chassis ground, the blower will run on HI.	
2. Compressor will not turn on (All other functions work).		System is not charged.	Replace BSC (This will require removal of evaporator from vehicle).	<b>Danger: Never bypass safety switch with engine running. Serious injury can result.</b>
		System is charged.	Charge system or bypass pressure switch.	
		System is not charged.	Check continuity to ground on white control head wire. Check for 5V on red control head wire.	
3. Compressor will not turn off (All other functions work).		System is charged.	Check 2-pin connector at ECU housing.	Disconnected or faulty thermistor will cause compressor to be disabled.
		System is not charged.	Check for faulty A/C potentiometer or associated wiring (Not applicable to 3-pot controls).	
		System is not charged.	Check for disconnected or faulty thermistor.	
		Check for faulty A/C potentiometer or associated wiring.	Repair or replace pot/control wiring.	Red wire at A/C pot should have approximately 5V with ignition on. White wire will have continuity to chassis ground. White/Blue wire should vary between 0V and 5V when lever is moved up or down.
		Check for faulty A/C relay.	Replace relay.	



# Troubleshooting Guide (Cont.)

Symptom	Condition	Checks	Actions	Notes
4. System will not turn on, or runs intermittently.	Works when engine is not running; shuts off when engine is started (Typically early Gen IV, but possible on all versions).	Noise interference from either ignition or alternator.	Install capacitors on ignition coil and alternator. Ensure good ground at all points. Relocate coil and associated wiring away from ECU and ECU wiring. Check for burned or loose plug wires.	Ignition noise (radiated or conducted) will cause the system to shut down due to high voltage spikes. If this is suspected, check with a quality oscilloscope. Spikes greater than 16V will shut down the ECU. Install a radio capacitor at the positive post of the ignition coil (See radio capacitor installation bulletin). A faulty alternator or worn out battery can also result in this condition.
		Verify connections on power lead, ignition lead, and both white ground wires.	Check for positive power at heater valve green wire and blower red wire. Check for ground on control head white wire.	
	Verify battery voltage is greater than 10 volts and less than 16.	Verify proper meter function by checking the condition of a known good battery.		
	Will not turn on under any conditions.			
5. Loss of mode door function.	No mode change at all.	Check for damaged mode switch or potentiometer and associated wiring.		Typically caused by evaporator housing installed in a bind in the vehicle. Be sure all mounting locations line up and don't have to be forced into position.
	Partial function of mode doors.	Check for obstructed or binding mode doors. Check for damaged stepper motor or wiring.		
6. Blower turns on and off rapidly.	Battery voltage is at least 12V.	Check for at least 12V at circuit breaker.	Ensure all system grounds and power connections are clean and tight.	System shuts off blower at 10V. Poor connections or weak battery can cause shutdown at up to 11V.
	Battery voltage is less than 12V.	Check for faulty battery or alternator.	Charge battery.	
7. Erratic functions of blower, mode, temp, etc.		Check for damaged switch or pot and associated wiring.	Repair or replace.	
	When ignition is turned on, blower momentarily comes on, then shuts off. This occurs with the blower switch in the OFF position.	This is an indicator that the system has been reset. Be sure the red power wire is on the battery post, and not on a switched source. Also, if the system is pulled below 7V for even a split second, the system will reset.	Run red power wire directly to battery.	



## Packing List Evaporator Kit (574074-EDZ)

No.	Qty.	Part No.	Description
1.	1	744004-VUE	Gen IV 4-Vent Evap. Sub Case
2.	1	784074-PMF	1970-74 Challenger/Cuda with A/C Accessory Kit

Checked By: \_\_\_\_\_  
 Packed By: \_\_\_\_\_  
 Date: \_\_\_\_\_

1

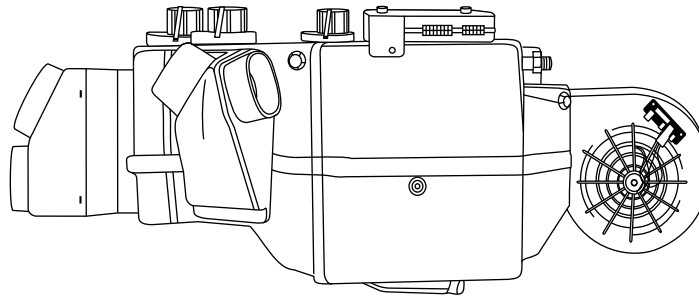

**Gen IV 4-Vent  
Evap. Sub Case  
744004-VUE**

2

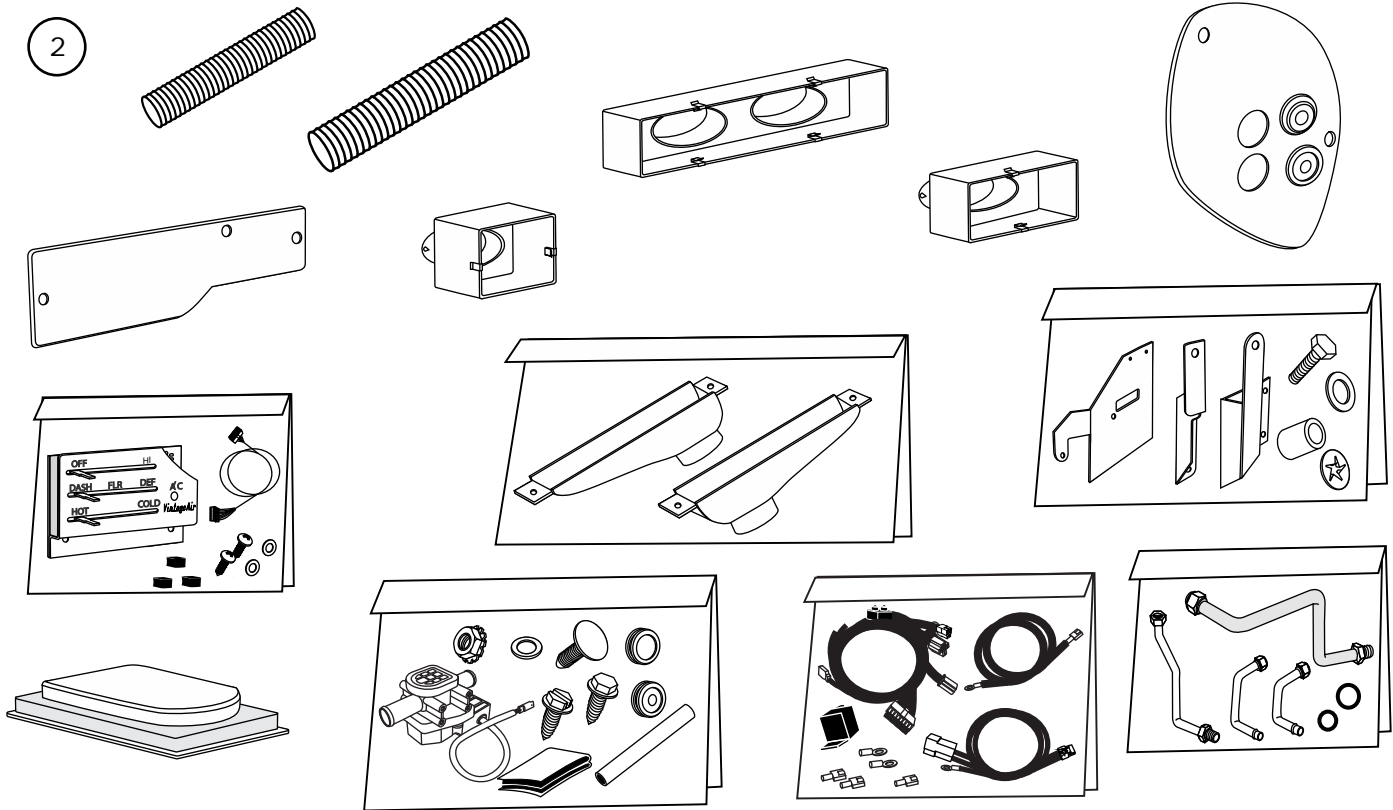

**Accessory Kit  
784074-PMF**

**NOTE: Images may not depict actual parts and quantities.  
Refer to packing list for actual parts and quantities.**