



an ISO 9001:2015 Registered Company

1970-72 Chevrolet Chevelle

*with Factory Air
Evaporator Kit
(565071)*



18865 Goll St. San Antonio, TX 78266
Phone: 800-862-6658
Sales: sales@vintageair.com
Tech Support: tech@vintageair.com
www.vintageair.com



www.vintageair.com

Table of Contents

Cover.....	1
Table of Contents.....	2
Packing List/Parts Disclaimer.....	3
Information Page.....	4
Wiring Notice.....	5
Engine Compartment Disassembly.....	6
Condenser Assembly and Installation, Compressor and Brackets, Passenger Compartment Disassembly.....	7
Firewall Modification, Defrost Duct Installation, Hose Adapter Installation.....	8
Fresh Air Cap & Kick Panel Cover Preparation.....	9
Fresh Air Cap & Kick Panel Cover Preparation (Cont.), Wiring Installation.....	10
Wiring Installation (Cont.).....	11
Kick Panel Cover Installation, Fresh Air Cap Installation.....	12
Firewall Cover Installation.....	13
Evaporator Installation.....	14
Evaporator Installation (Cont.).....	15
Center Louver Installation.....	16
Drain Hose Installation, Lubricating O-rings, A/C Hose Installation.....	17
Heater Hose & Heater Control Valve Installation, A/C and Heater Hose Routing.....	18
Final Steps.....	19
Control Panel & Duct Hose Routing.....	20
Wiring Diagram.....	21
Gen IV Wiring Connection Instruction.....	22
Operation of Controls.....	23
Troubleshooting Guide.....	24
Troubleshooting Guide (Cont.).....	25
Packing List.....	26



www.vintageair.com

Packing List: Evaporator Kit (565071)

No.	Qty.	Part No.	Description
1.	1	762169	Gen IV Evaporator Sub Case
2.	1	784172	Accessory Kit

**** Before beginning installation, open all packages and check contents of shipment. Please report any shortages directly to Vintage Air within 15 days. After 15 days, Vintage Air will not be responsible for missing or damaged items.**

1

Gen IV Evaporator
Sub Case
762169

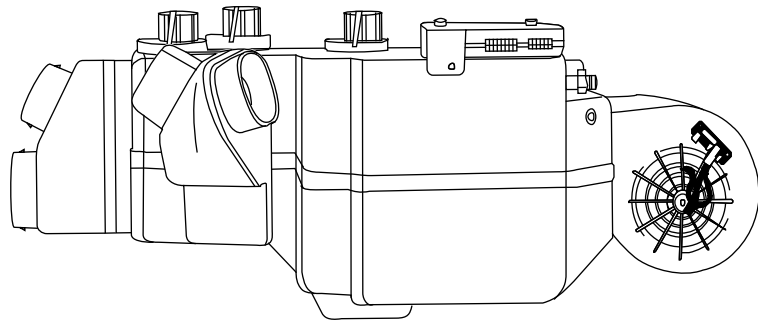

2

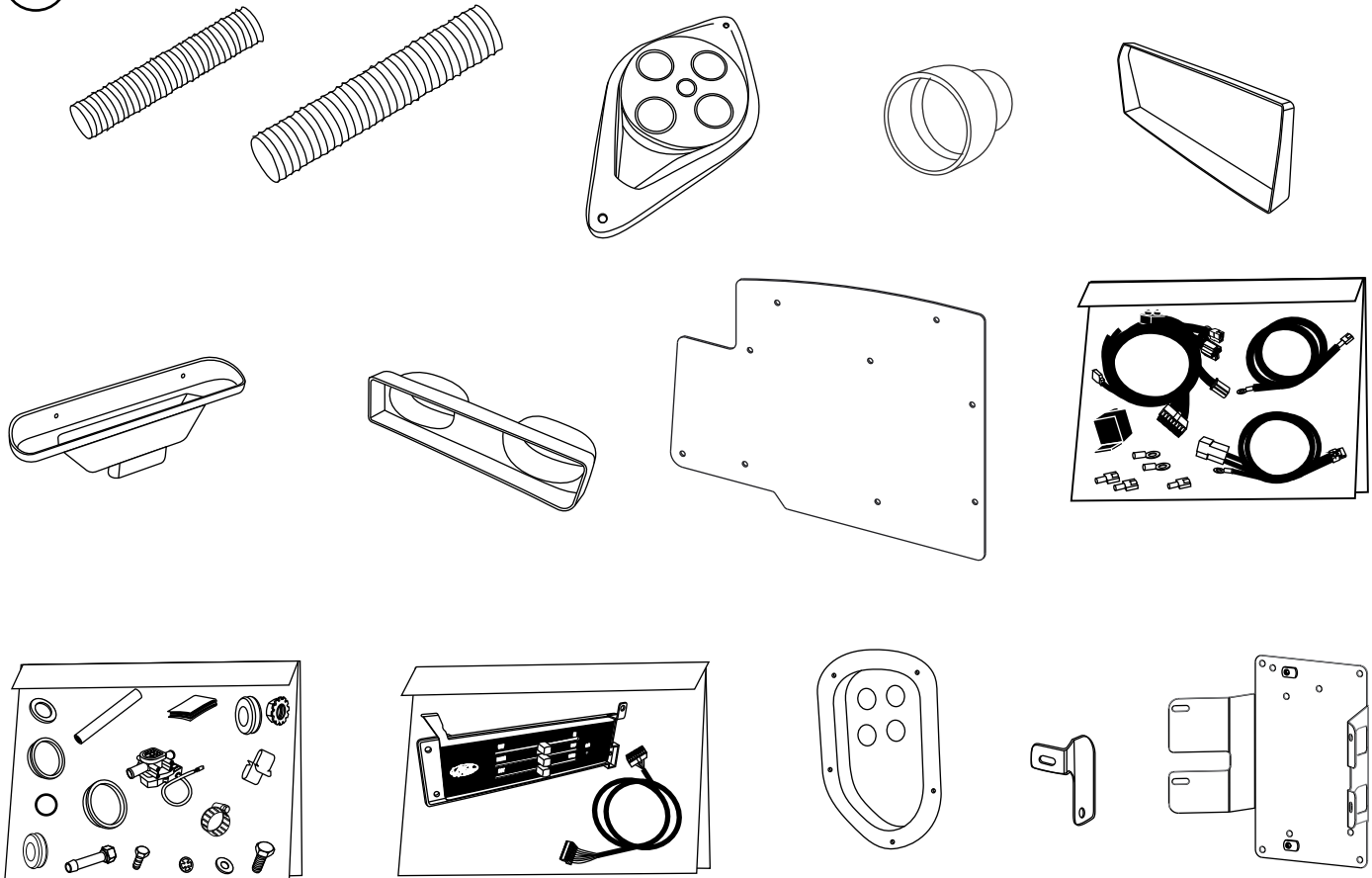

Accessory Kit
784172

NOTE: Images may not depict actual parts and quantities. Refer to packing list for actual parts and quantities.



www.vintageair.com

Important Notice—Please Read

For Maximum System Performance, Vintage Air Recommends the Following:

NOTE: Vintage Air systems are designed to operate with R134a refrigerant only. Use of any other refrigerant could damage your A/C system and/or vehicle, and possibly cause a fire, in addition to potentially voiding the warranties of the A/C system and its components.

Refrigerant Capacities:

Vintage Air System: 1.8 lbs. (28.8 oz.) or 816 grams of **R134a**, charged by weight with a quality charging station or scale. **NOTE: Use of the proper type and amount of refrigerant is critical to system operation and performance.**

Other Systems: Consult manufacturer's guidelines.

Lubricant Capacities:

New Vintage Air-supplied Sanden Compressor: No additional oil needed (Compressor is shipped with proper oil charge).

All Other Compressors: Consult manufacturer (Some compressors are shipped dry and will need oil added).

Safety Switches

Your Vintage Air system is equipped with a binary pressure safety switch. A binary switch disengages the compressor clutch in cases of extreme low pressure conditions (Refrigerant Loss) or excessively high head pressure (406 PSI) to prevent compressor damage or hose rupture. A trinary switch combines Hi/Lo pressure protection with an electric fan operation signal at 254 PSI, and should be substituted for use with electric fans. Compressor safety switches are extremely important since an A/C system relies on refrigerant to circulate lubricant.

Service Info:

Protect Your Investment: Prior to assembly, it is critical that the compressor, evaporator, A/C hoses and fittings, hardlines, condenser and receiver/drier remained capped. Removing caps prior to assembly will allow moisture, insects and debris into the components, possibly leading to reduced performance and/or premature failure of your A/C system. This is especially important with the receiver/drier.

Additionally, when caps are removed for assembly, **BE CAREFUL!** Some components are shipped under pressure with dry nitrogen.

Evacuate the System for 35-45 Minutes: Ensure that system components (Drier, compressor, evaporator and condenser) are at a temperature of at least 85° F. On a cool day, the components can be heated with a heat gun **or** by running the engine with the heater on before evacuating. Leak check and charge to specifications.

Bolts Passing Through Cowl and/or Firewall:

To ensure a watertight seal between the passenger compartment and the vehicle exterior, for all bolts passing through the cowl and/or firewall, Vintage Air recommends coating the threads with silicone prior to installation.

Heater Hose (Not Included With This Kit):

Heater hose may be purchased from Vintage Air (Part# 31800-VUD) or your local parts retailer. Routing and required length will vary based on installer preference.



www.vintageair.com

Important Wiring Notice—Please Read

Some Vehicles May Have Had Some or All of Their Radio Interference Capacitors Removed. There Should Be a Capacitor Found At Each of the Following Locations:

- 1. On the positive terminal of the ignition coil.**
- 2. If there is a generator, on the armature terminal of the generator.**
- 3. If there is a generator, on the battery terminal of the voltage regulator.**

Most alternators have a capacitor installed internally to eliminate what is called “whining” as the engine is revved. If whining is heard in the radio, or just to be extra cautious, a radio interference capacitor can be added to the battery terminal of the alternator.

It is also important that the battery lead is in good shape and that the ground leads are not compromised. There should be a heavy ground from the battery to the engine block, and additional grounds to the body and chassis.

If these precautions are not observed, it is possible for voltage spikes to be present on the battery leads. These spikes come from ignition systems, charging systems, and from switching some of the vehicle’s other systems on and off. Modern computer-operated equipment can be sensitive to voltage spikes on the power leads, which can cause unexpected resets, strange behavior, and/or permanent damage.

Vintage Air strives to harden our products against these types of electrical noise, but there is a point where a vehicle’s electrical system can be degraded so much that nothing can help.

Radio interference capacitors should be available at most auto and truck parts suppliers. They typically are cylindrical in shape, a little over an inch long, a little over a half inch in diameter, and they have a single lead coming from one end of the cylinder with a terminal on the end of the wire, as well as a mounting clip which is screwed into a good ground on the vehicle. The specific value of the capacitance is not too significant in comparison to ignition capacitors that are matched with the coil to reduce pitting of the points.

- Care must be taken, when installing the compressor lead, not to short it to ground. The compressor lead must not be connected to a condenser fan or to any other auxiliary device. Shorting to ground or connecting to a condenser fan or any other auxiliary device may damage wiring, the compressor relay, and/or cause a malfunction.
- When installing ground leads on Gen IV systems, the blower control ground and ECU ground must be connected directly to the negative battery post.
- For proper system operation, the heater control valve must be connected to the ECU.



www.vintageair.com

Engine Compartment Disassembly

NOTE: Before starting the installation, check the function of the vehicle (horn, lights, etc.) for proper operation, and study the instructions, illustrations, & diagrams.

Perform the Following:

1. Disconnect the battery.
2. Remove the battery and battery tray (retain).
3. Drain the radiator.
4. Evacuate the A/C system if necessary.
5. Remove the condenser and drier (discard) (See Figure 1, below).
6. Remove the A/C lines from the compressor to the evaporator (discard) (See Figure 1, below).
7. Remove the compressor and bracket (discard) (See Figure 1, below).
8. Remove the evaporator blower assembly (discard). **NOTE: To remove the evaporator and blower assembly (under hood) and the air distribution system (under dash), the factory manual recommends removing the passenger side inner fender.**
9. Remove the heater hoses, A/C hoses, hardlines and muffler (discard) (See Figure 1, below).
10. Remove the A/C and heater wiring/vacuum harness molded grommet (See Figure 1, below).
11. Install the supplied 1 3/4" plug in the firewall as shown in Figure 1, below.

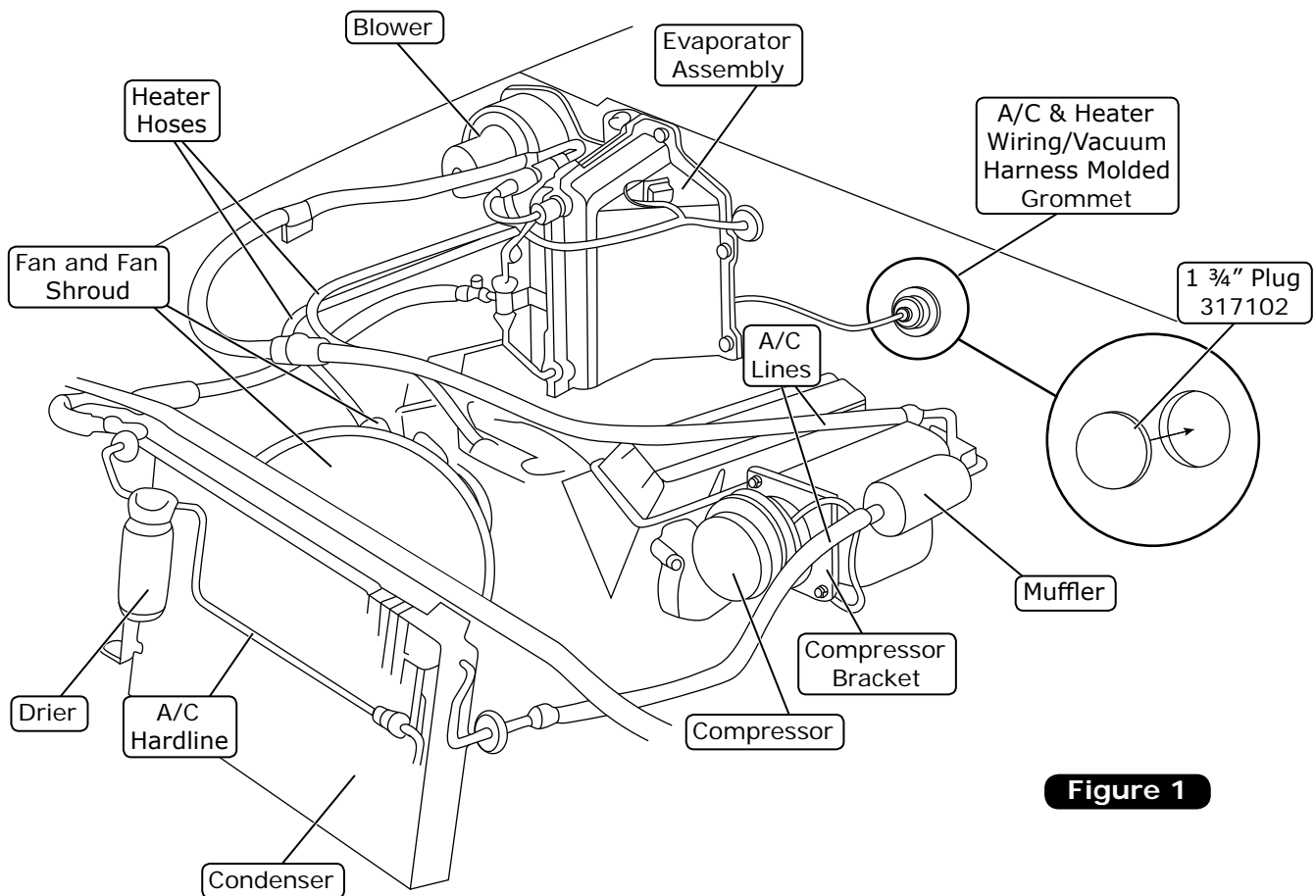

Figure 1



www.vintageair.com

Condenser Assembly and Installation

1. Refer to separate instructions included with the condenser kit to install the condenser.
2. Binary switch installation (Refer to condenser instructions).

Compressor and Brackets

1. Refer to separate instructions included with the bracket kit to install the compressor bracket.

Passenger Compartment Disassembly

NOTE: Removal of dashboard is required to install the evaporator. Vintage Air recommends using the factory service manual when disassembling and reassembling the dashboard.

Perform the Following:

1. Remove the dash pad by removing the (6) screws (retain) (See Figure 1, below).
2. Lower the steering column. Protect the steering column with a cloth.
3. Disconnect all wires and cables from the instrument panel, speedometer, control panel and radio.
4. Remove the lower dash by removing the (8) bolts (retain).
5. Remove all hoses and ducting from the louvers (See Figure 1, below).
6. Remove the (2) under dash louver assemblies (discard) (See Figure 1, below).
7. Remove the defrost duct assembly by removing the (4) screws (See Figure 2, below).
8. Remove the A/C and heater assembly (discard) (See Figure 2, below).
9. Remove the passenger side kick panel/fresh air door assembly as shown in Figures 3 & 4, below.

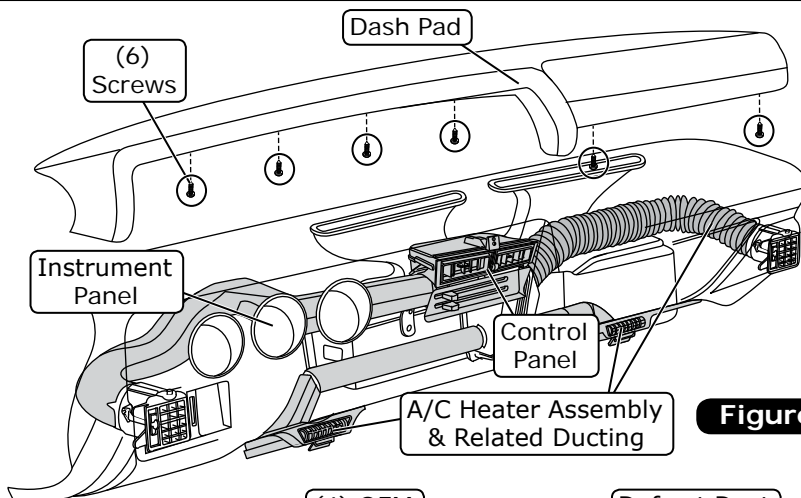

Figure 1

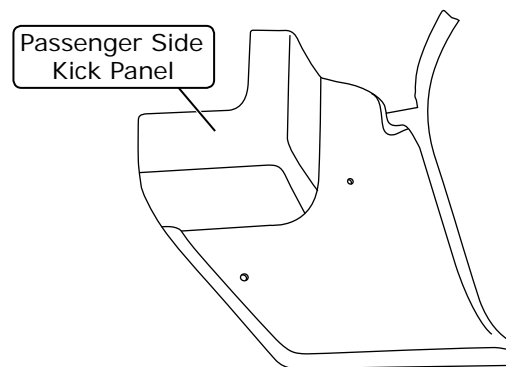

Figure 3

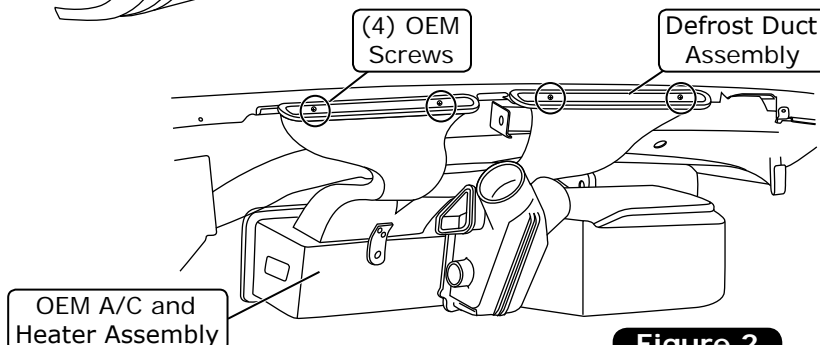

Figure 2

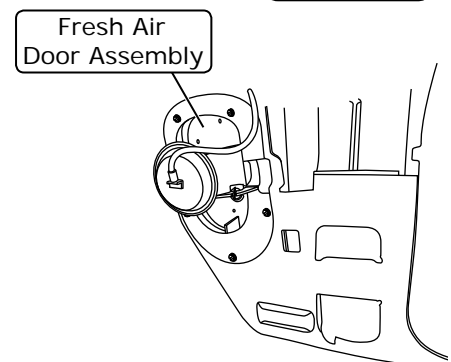

Figure 4



www.vintageair.com

Firewall Modification

1. Flatten the edges of the firewall opening (See Photo 1, below).
2. Place the firewall cover onto the firewall. Locate the (8) mounting holes and enlarge holes in the firewall to 9/32" to accommodate the 1/4-20 mounting bolts (See Figure 1, below).

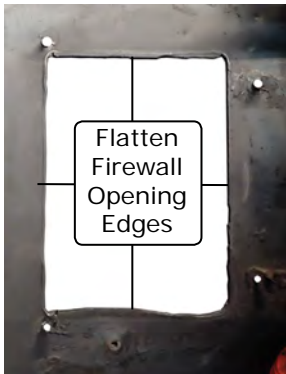

Photo 1

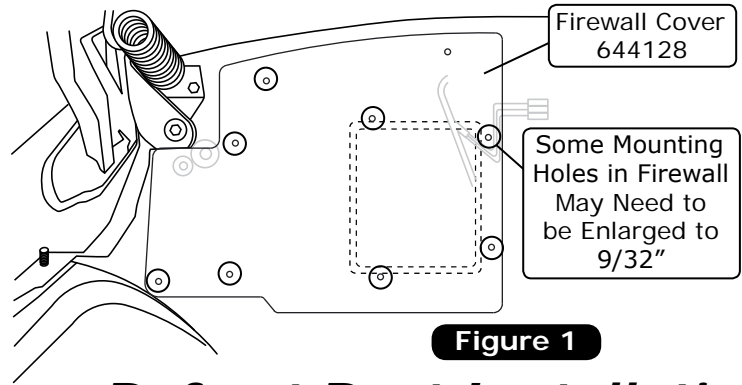

Figure 1

Defrost Duct Installation

1. Install the (2) defrost ducts under the dash, and secure them using OEM screws as shown in Figure 1, below.

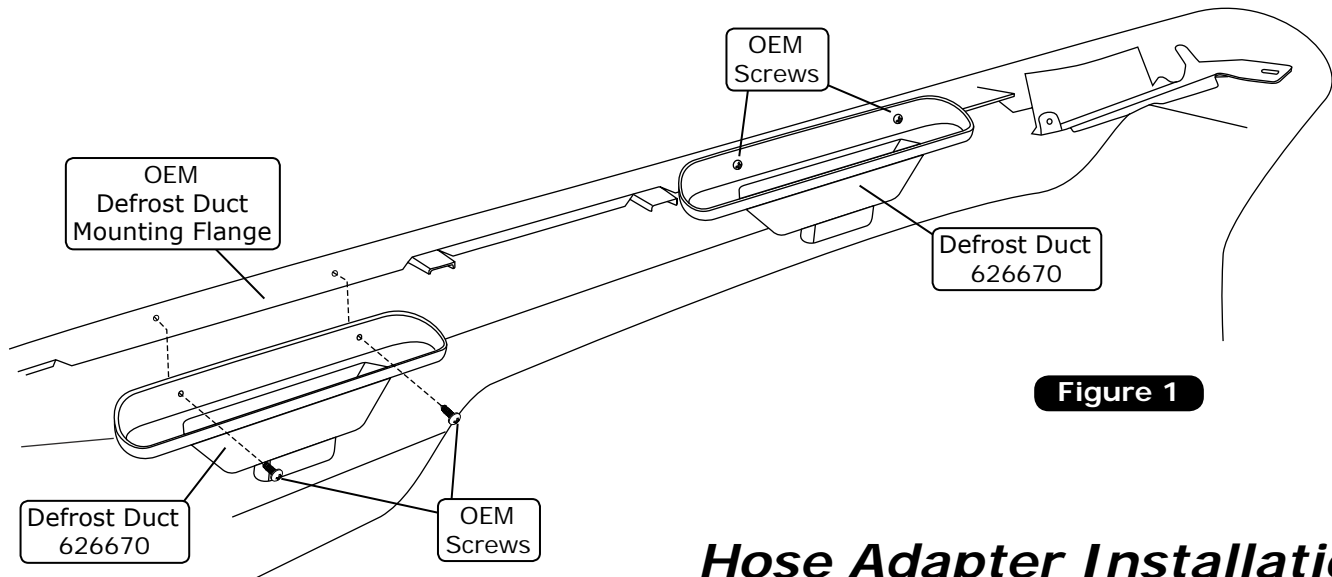

Figure 1

Hose Adapter Installation

1. Install (3) S-clips onto the (2) hose adapters as shown in Figure 1, below.
2. Install the driver & passenger side hose adapters inside the OEM louvers (See Figure 1, below).

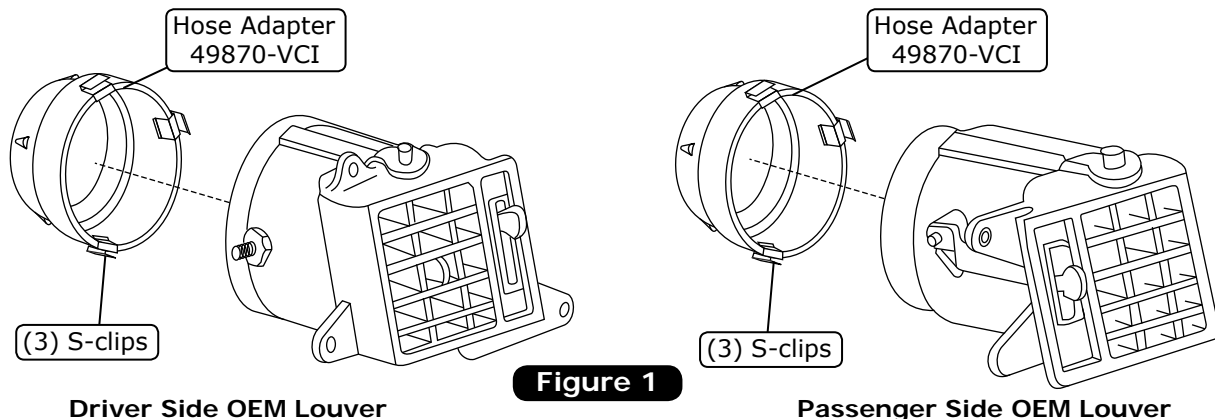

Figure 1

Driver Side OEM Louver

Passenger Side OEM Louver



www.vintageair.com

Fresh Air Cap & Kick Panel Cover Preparation

1. Install (4) large grommets and a 7/8" grommet into the fresh air cap (See Photos 1 & 2, below).
2. On the inside of the fresh air cap, the letter "T" indicates the top mounting hole for the firewall (See Photo 3, below).
3. From the center of the bottom left hole in the kick panel cover, measure 1 1/2" down. Mark and drill a 5/8" hole for the 7/8" grommet (See Photos 4 & 5, below).

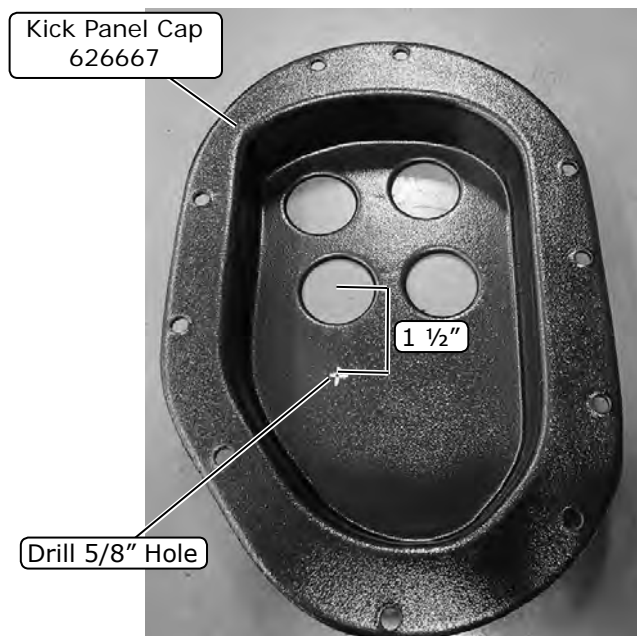
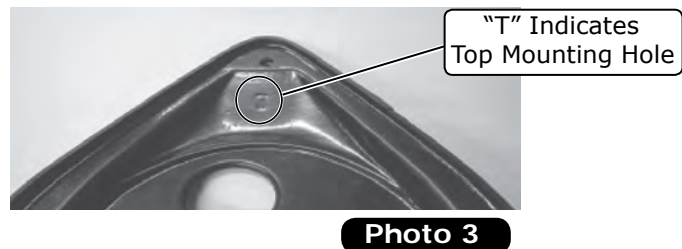
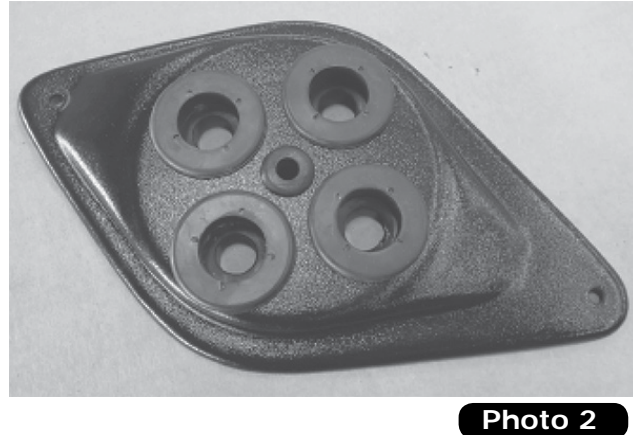
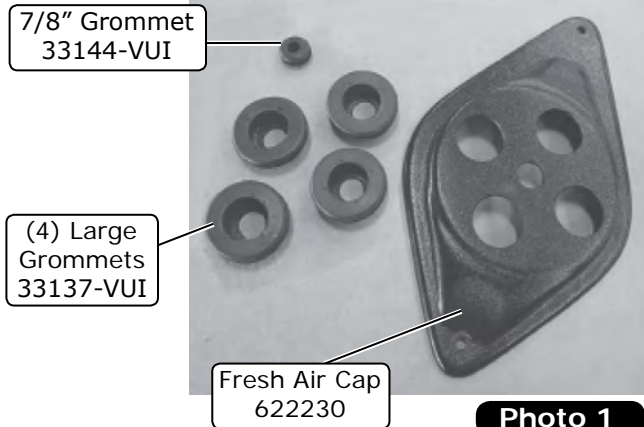



www.vintageair.com

Fresh Air Cap & Kick Panel Cover Preparation (Cont.)

4. Install (4) large grommets and a 7/8" grommet into the kick panel cover (See Photos 6 & 7, below).



Photo 6



Photo 7

Wiring Installation

1. From the passenger compartment, route the heater control valve connector and wiring (red, white and green) through the 7/8" grommet in the kick panel cover (See Figure 1, below). **NOTE: Leave approximately 1" of wiring between the kick panel cover and the harness connector. This allows enough wiring to reach the harness.**
2. Disconnect the circuit breaker from the main wiring harness (See Photo 1, below).

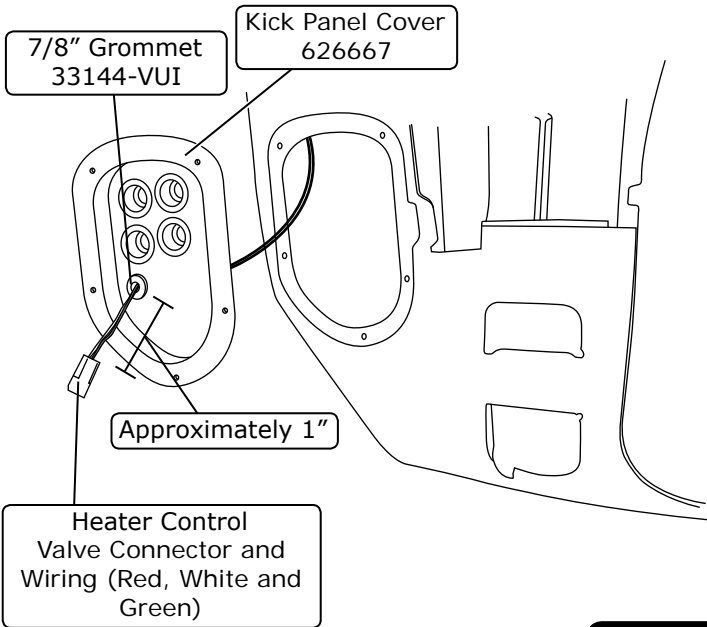

Figure 1

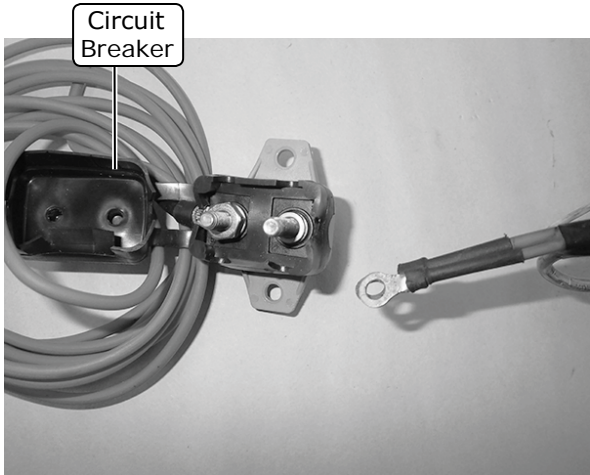

Photo 1



www.vintageair.com

Wiring Installation (Cont.)

3. Route the red, white and blue wires from the main wiring harness through the 7/8" grommet in the kick panel cover (See Photo 2, below). **NOTE: Leave approximately 5" of wiring between the relay and the kick panel cover. This allows enough wiring to secure the relay to the mounting position.**
4. Route the heater control valve wiring (red, white and green) through the 7/8" grommet in the fresh air cap (See Photo 3, below).
5. Route the main harness wiring (red, white and blue) through the 7/8" grommet in the fresh air cap (See Photo 4, below).

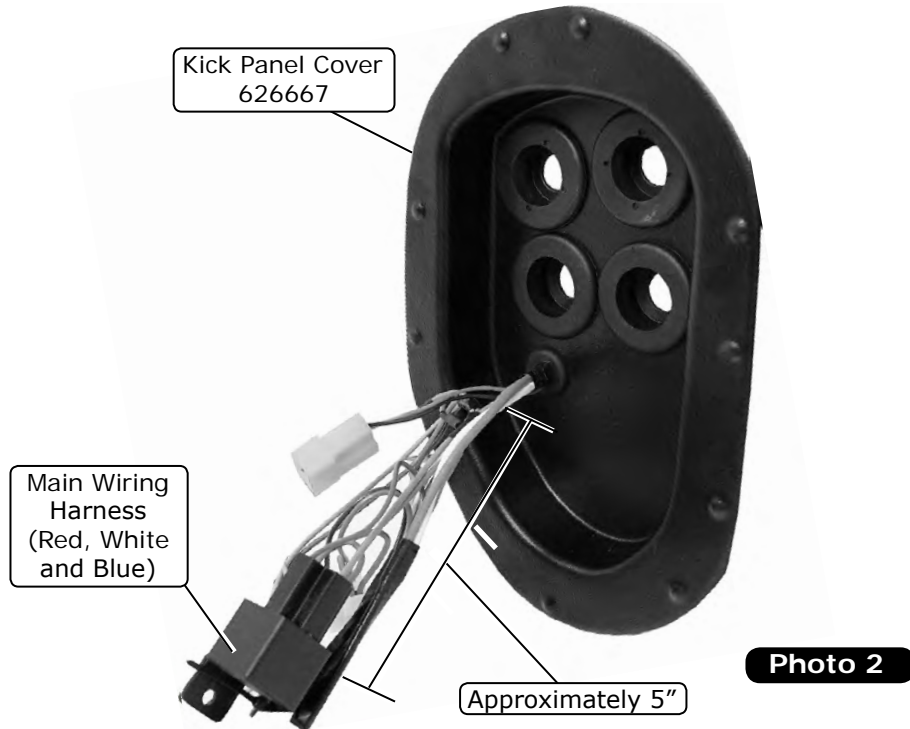

Photo 3

Photo 4



www.vintageair.com

Kick Panel Cover Installation

1. Route the A/C and heater hoses through the kick panel cover as shown in Figure 1, below.
2. Apply 1/4" bead of silicone around the back side of the kick panel cover as shown in Figure 1, below.
3. Secure the kick panel cover using (5) #8 x 1 1/4" screws as shown in Figure 1, below.

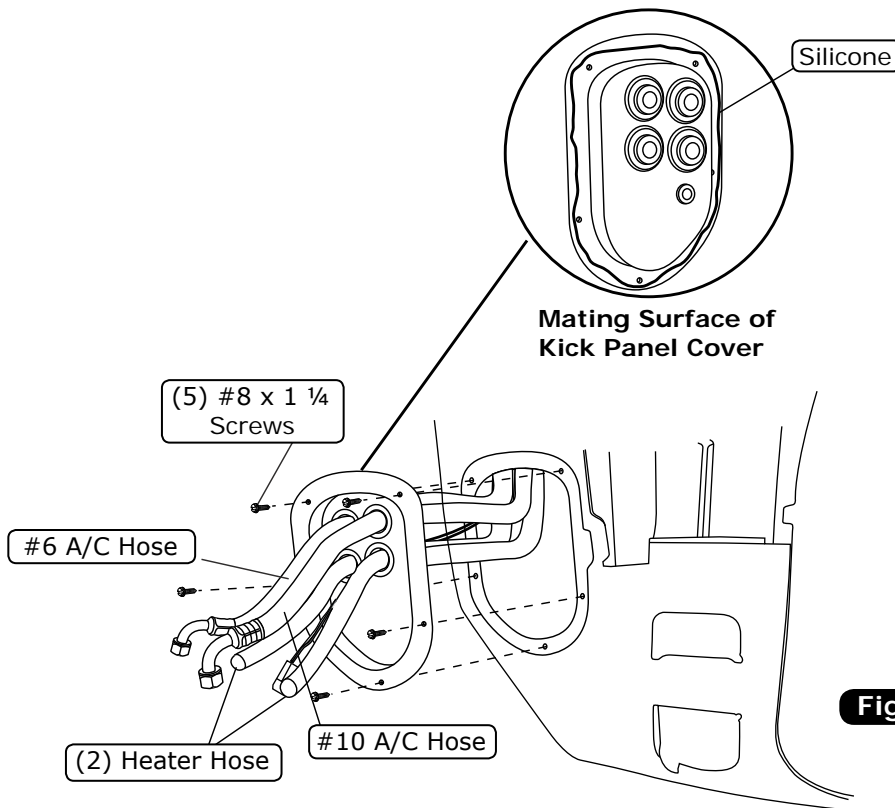

Figure 1

Fresh Air Cap Installation

NOTE: The fresh air cap installs on the engine side of the firewall.

1. Route the A/C and heater hoses through the fresh air cap as shown in Figure 1, below.
2. Gently pull the slack from the hoses in the passenger compartment, making sure the hoses are not kinked.
3. Slide the fresh air cap into position, and secure it to the firewall using (2) #14 x 3/4" sheet metal screws (See Photo 1, below).
4. Apply silicone around the outer edge of the fresh air cap (See Photo 1, below).

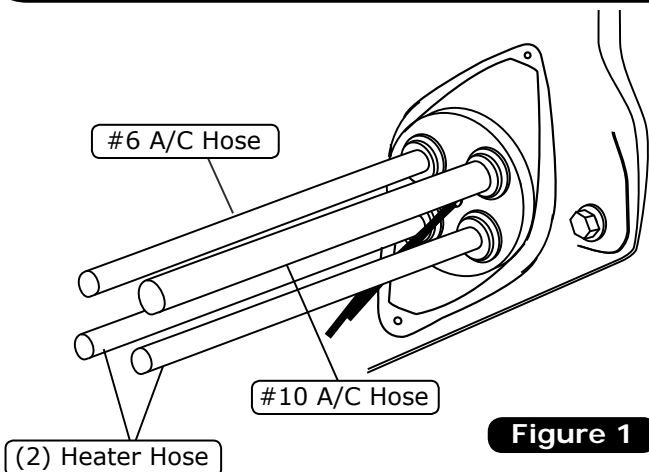

Figure 1

Apply Silicone Around Fresh Air Cap

Secure Fresh Air Cap with (2) #14 x 3/4" Sheet Metal Screws



Photo 1



www.vintageair.com

Firewall Cover Installation

1. Loosen or remove the wire loom bracket (if equipped) (retain) (See Figure 1, below).
2. Install (6) 1/4-20 x 3/4" bolts with pushnut bolt retainers onto the firewall cover (See Photo 1, below).
3. Temporarily install the firewall cover onto the firewall from the engine side (See Figure 2, below).
4. From the passenger compartment, trace around the firewall opening onto the firewall cover (See Figure 3, below).
5. Remove the firewall cover, and apply insulation to the traced area (See Photo 2, below).
6. Apply silicone to the mating surface of the firewall cover (See Figure 4, below).
7. Install the firewall cover and secure it using (6) 5/8" washers and (6) 1/4-20 nuts with star washers (See Figure 5, below).

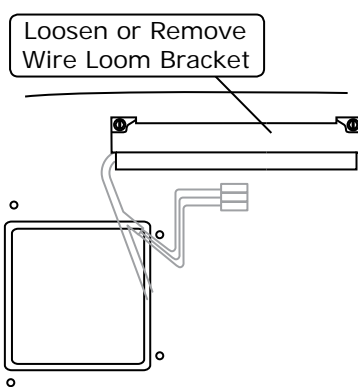

Figure 1

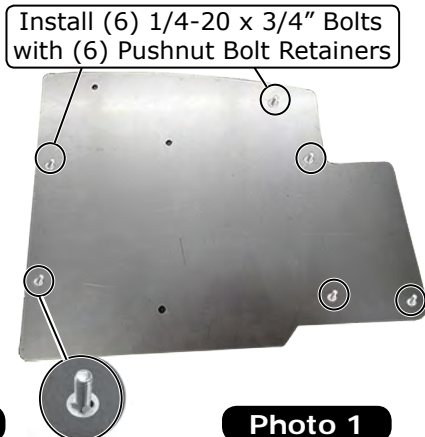

Photo 1

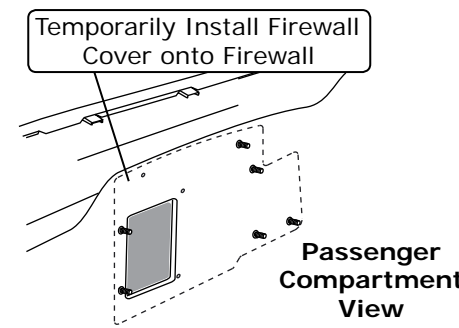

Figure 2

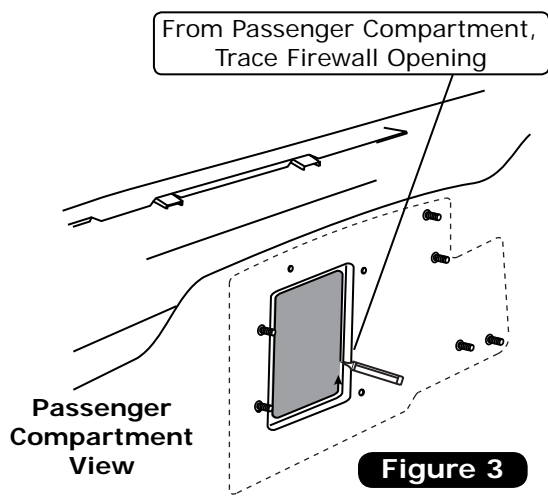

Figure 3



Photo 2

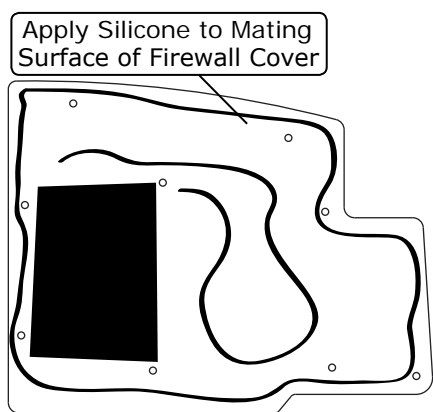

Figure 4

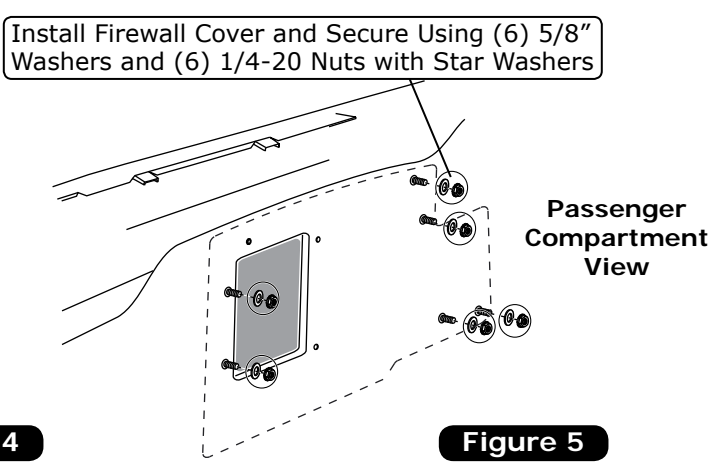

Figure 5



www.vintageair.com

Evaporator Installation

NOTE: To ensure a watertight seal between the passenger compartment and the vehicle exterior, for all bolts passing through the firewall, Vintage Air recommends coating the threads with silicone prior to installation.

1. On a workbench, install the (2) heater fittings with properly lubricated O-rings (See Lubricating O-rings, Page 14, and Figure 1, below).
2. Install the (2) 1/4-20 x 1 1/2" studs into the evaporator rear bracket (See Photo 1, below).
3. Install the evaporator front & rear brackets onto the evaporator, and secure them using (5) 1/4-20 x 1/2" hex bolts as shown in Figures 2 & 3, below.

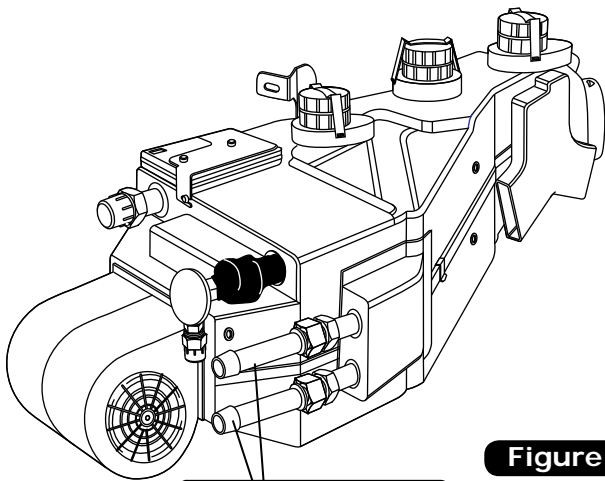

Install (2) Heater Fittings with Properly Lubricated O-Rings

Figure 1



Install (2) 1/4-20 x 1 1/2" Studs into Evaporator Rear Bracket

Photo 1

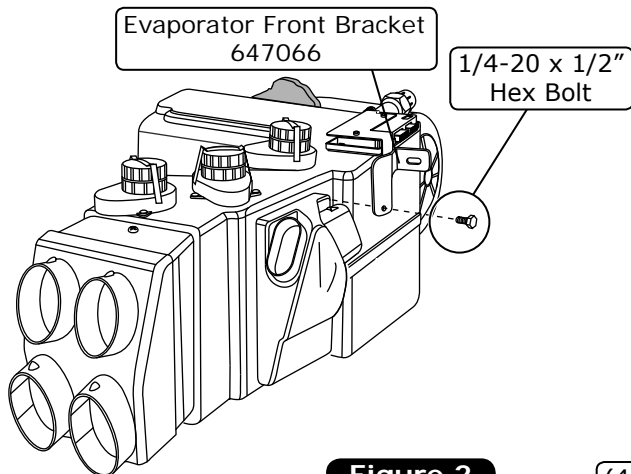

Evaporator Front Bracket
647066

1/4-20 x 1/2"
Hex Bolt

Figure 2

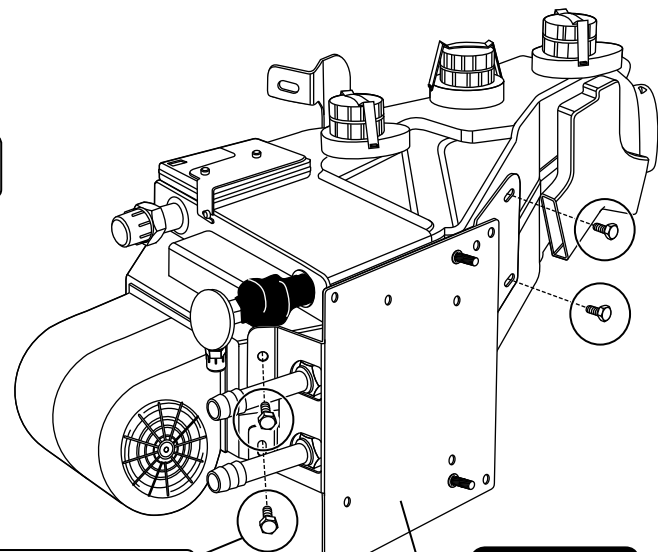

(4) 1/4-20 x 1/2"
Hex Bolts

Figure 3

Evaporator Rear Bracket
644104



www.vintageair.com

Evaporator Installation (Cont.)

4. Lay the evaporator sub case on the passenger side floorboard. Install the A/C & heater hoses on the evaporator as shown in Figure 4, below, and A/C hose installation instructions on Page 17. **NOTE: Wrap the #10 fitting connections with press tape (See Figure 4, below).**
5. Lift the evaporator unit up under the dashboard. Secure it loosely to the firewall from the engine compartment side using (2) 1/4-20 nuts with star washers on the (2) 1/4-20 x 1 1/2" studs (See Figure 5, below). **NOTE: To ensure proper drainage, it is very important that the evaporator is level, both left-right and fore-aft. Check for level on the flat portions of the case around the drain.**
6. Using the OEM bolt, secure the evaporator front bracket between the dash bracket and the cowl bracket (See Figure 5, below).
7. Replace the (2) 1/4-20 x 1 1/2" studs from the engine compartment with (2) 1/4-20 x 3/4" bolts (See Photo 2, below). **NOTE: Do not fully tighten at this time**
8. Verify that evaporator unit is level and square to the dash; then tighten all mounting bolts. **NOTE: Tighten the bolts on the firewall first. Then tighten the front mounting bracket.**

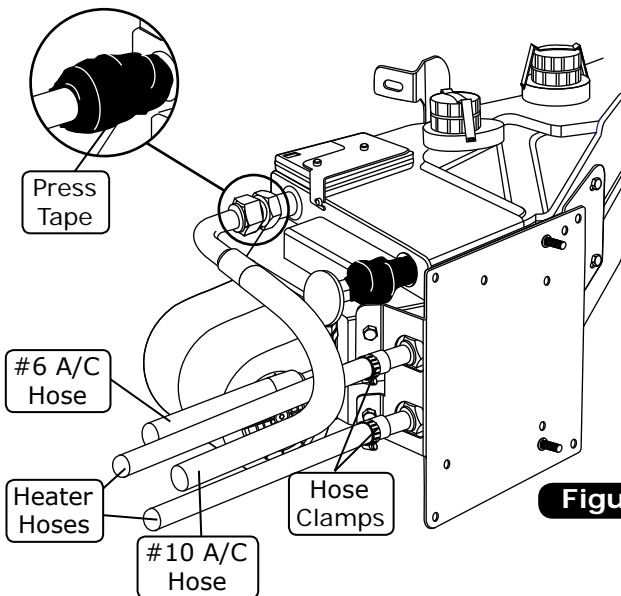

Figure 4

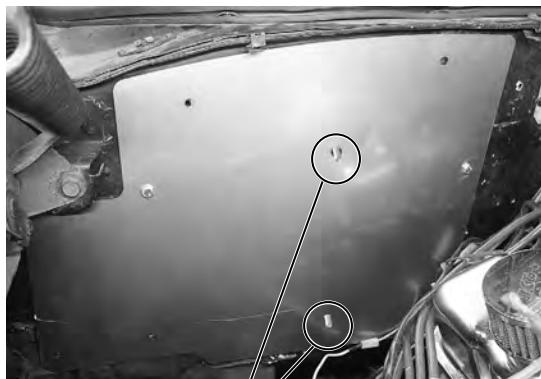

Photo 2

From Engine Compartment,
Replace (2) 1/4-20 x 1 1/2" Studs
with (2) 1/4-20 x 3/4" Bolts

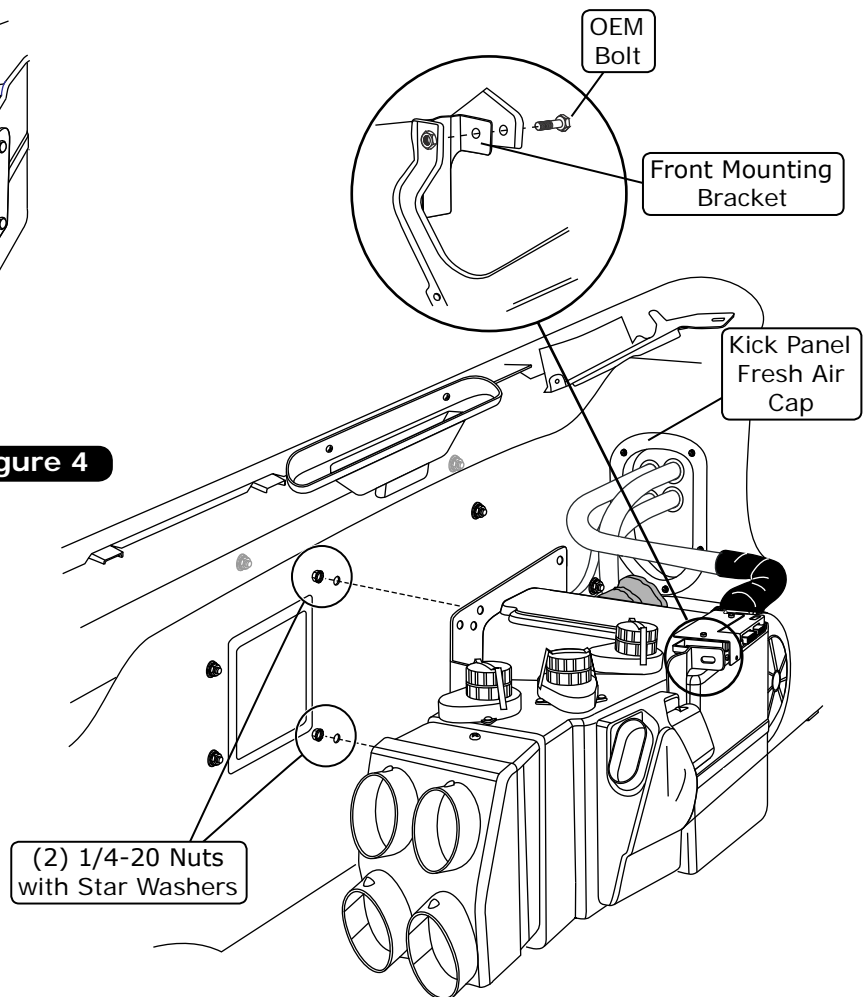

Figure 5



www.vintageair.com

Center Louver Installation

1. Remove the center louver door flap (See Figure 1, below).
2. Modify the center louver assembly as shown in Figures 2 & 3, below.
3. Install (4) S-clips onto the hose adapter (See Figure 4, below).
4. Install the center louver hose adapter onto the center louver assembly as shown in Figure 4, below.

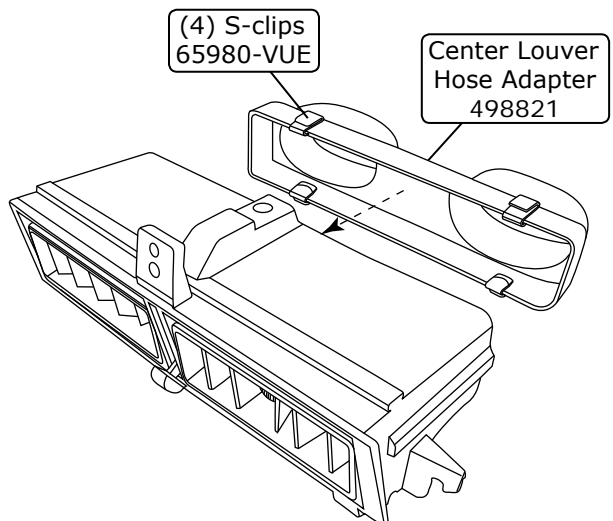
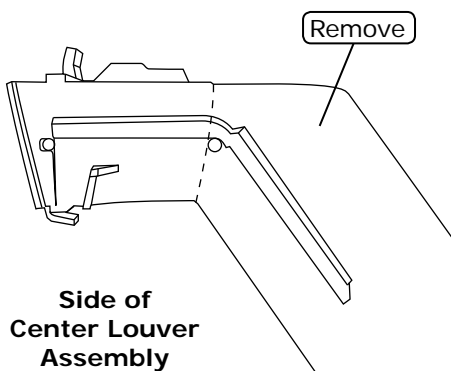
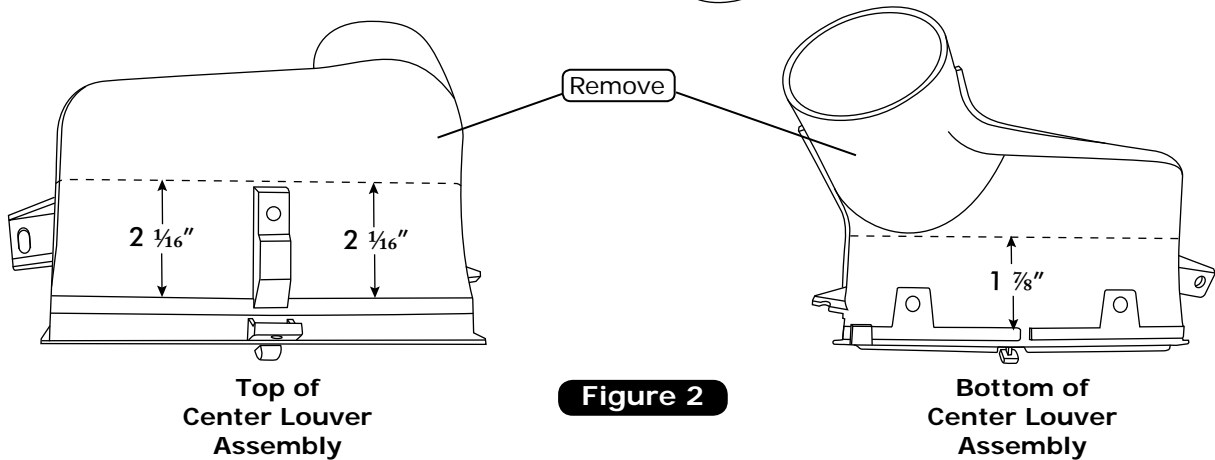
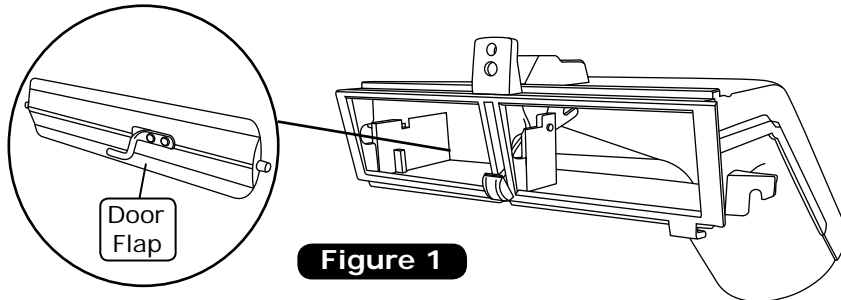



www.vintageair.com

Drain Hose Installation

1. Locate the evaporator drain on the bottom of the evaporator case.
2. In line with the drain, lightly make a mark on the firewall. Measure 1" down and 2 1/2" to the left. Drill a 5/8" hole through the firewall (See Figure 1, below).
3. Install the drain hose to the outlet on the bottom of the evaporator unit, and route it through the firewall (See Figure 2, below).

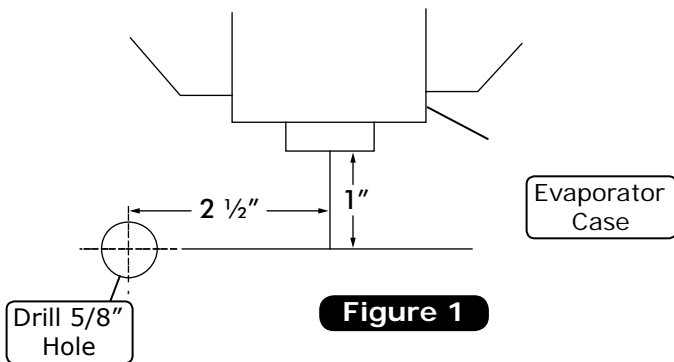

Figure 1

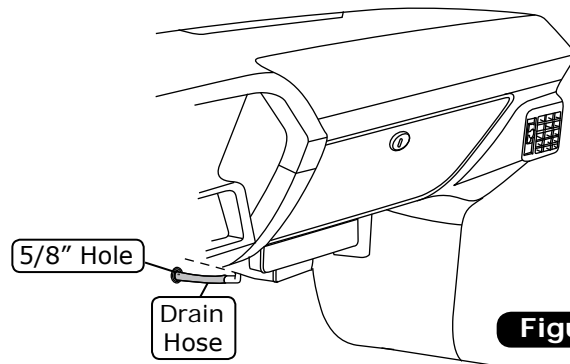
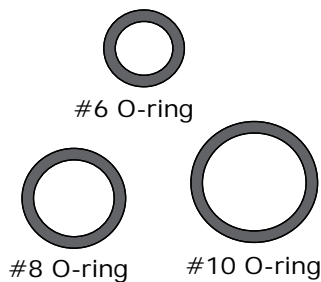
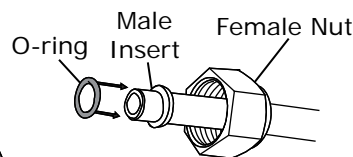

Figure 2

Lubricating O-rings



NOTE: Standard torque specifications:
 #6: 11 to 13 ft-lb.
 #8: 15 to 20 ft-lb.
 #10: 21 to 27 ft-lb.



For a proper seal of fittings: Install supplied O-rings as shown, and lubricate with supplied oil.

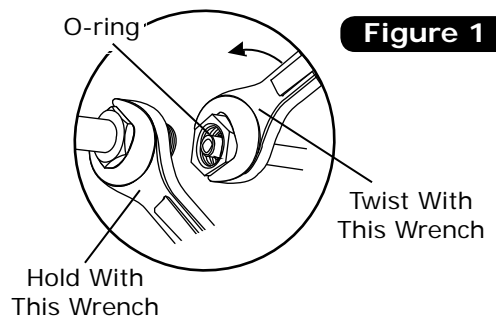
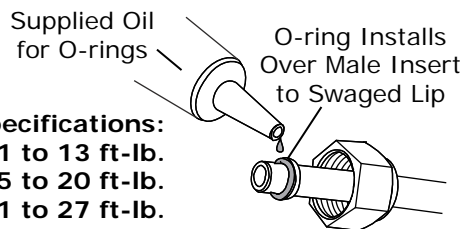

Figure 1

A/C Hose Installation

Standard Hose Kit:

1. Locate the #8 compressor A/C hose. Lubricate (2) #8 O-rings (See Figure 1, above) and connect the 135° female fitting with 134a service port to the #8 discharge port on the compressor. Then route the straight female fitting to the #8 condenser hardline coming through the core support (See Figure 1, Page 18). Tighten each fitting connection as shown in Figure 1, above.
2. Locate the #10 compressor A/C hose. Lubricate (2) #10 O-rings (See Figure 1, above) and connect the #10 135° female fitting with 134a service port to the #10 suction port on the compressor. Then route the 90° female fitting to the #10 fitting on the evaporator (See Figure 4, Page 15, and Figure 1, Page 18). Tighten each fitting connection as shown in Figure 1, above.
3. Locate the #6 evaporator A/C hose. Lubricate (2) #6 O-rings (See Figure 1, above) and connect the straight female fitting to the #6 hardline coming through the core support from the drier. Then route the 90° female fitting to the #6 fitting on the evaporator (See Figure 4, Page 15, and Figure 1, Page 18). Tighten each fitting connection as shown in Figure 1, above.
4. Using a #10 Adel clamp and a 10-32 x 1/2" pan head screw with a nut, secure the #10 A/C hose to the alternator bracket as shown in Figure 1, Page 18.

Modified Hose Kit:

1. Refer to separate instructions included with modified hose kit.



www.vintageair.com

Heater Hose & Heater Control Valve Installation

1. Route a piece of heater hose from the water pump to the top heater fitting of the heater core as shown in Figure 4, Page 15, and Figure 1, below. Secure using hose clamps.
2. Route a piece of heater hose from the intake to the bottom heater fitting of the heater core as shown in Figure 4, Page 15, and Figure 1, below. **NOTE: Install heater control valve in line with intake manifold (pressure side) heater hose. Secure using hose clamps as shown in Figure 1, below. Also note proper flow direction.**

A/C & Heater Hose Routing

NOTE: Vintage Air Systems use 5/8" heater connections. On engines equipped with 3/4" hose nipples, these will need to be removed and replaced with 5/8" nipples (not supplied). For water pumps with a cast-in 3/4" heater outlet, a 3/4" x 5/8" reducer fitting in the heater hose (not supplied) or molded hose (Vintage Air Part # 099010) will need to be installed.

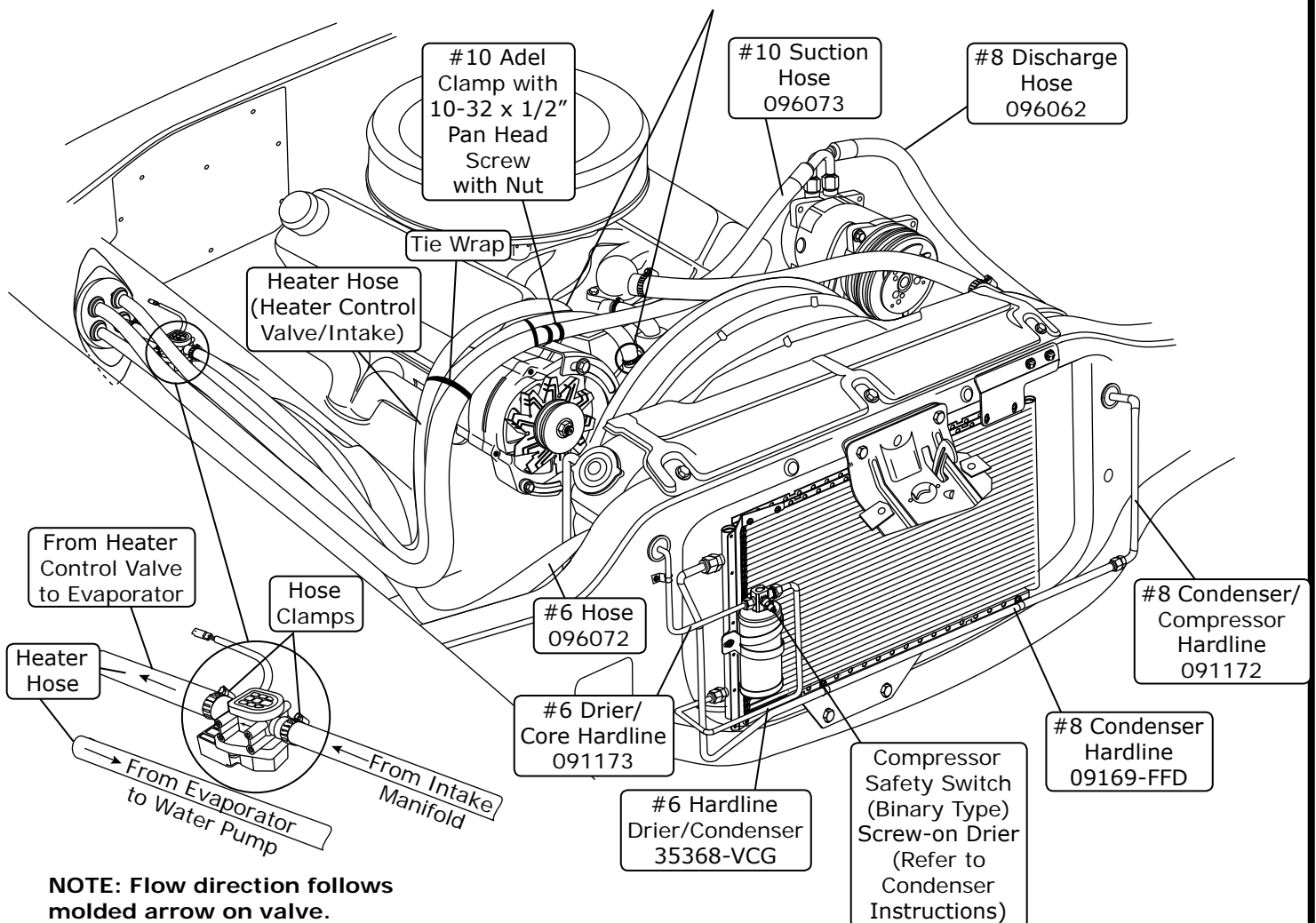

Figure 1



www.vintageair.com

Final Steps

1. Install the duct hoses as shown in Figure 2, Page 20.
2. Install the control panel assembly. Refer to the control panel instructions.
3. Plug the wiring harnesses into the ECU module on the sub case as shown in Figure 1, Page 20. Wire according to the wiring diagrams on Pages 21 and 22.
4. Modify the glove box as shown in Figure 2, below.
5. Install (4) S-clips onto the glove box cap, and install the glove box cap onto the glove box as shown in Figure 3, below.
6. Modify the passenger side kick panel as shown in Figure 3, below.
7. Reinstall the kick panel with OEM screws.
8. Reinstall all previously removed items (battery tray, battery, and inner fender).
9. Fill radiator with at least a 50/50 mixture of approved antifreeze and distilled water. It is the owner's responsibility to keep the freeze protection at the proper level for the climate in which the vehicle is operated. Failure to follow antifreeze recommendations will cause heater core to corrode prematurely and possibly burst in A/C mode and/or freezing weather, voiding your warranty.
10. Double check all fittings, brackets and belts for tightness.
11. Vintage Air recommends that all A/C systems be serviced by a licensed automotive A/C technician.
12. Evacuate the system for a minimum of 45 minutes prior to charging, and perform a leak check prior to servicing.
13. Charge the system to the capacities stated on Page 4 of this instruction manual.
14. See Operation of Controls procedures on Page 23.

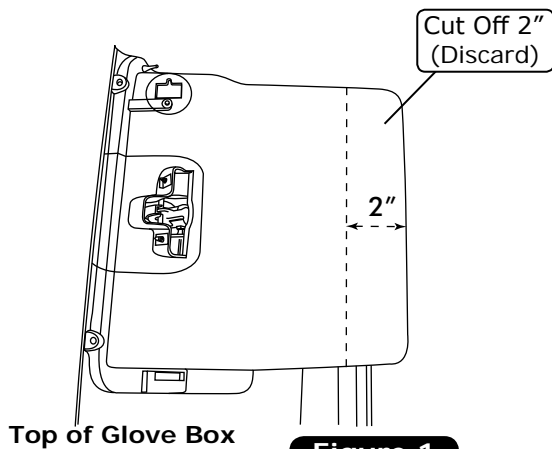

Figure 1

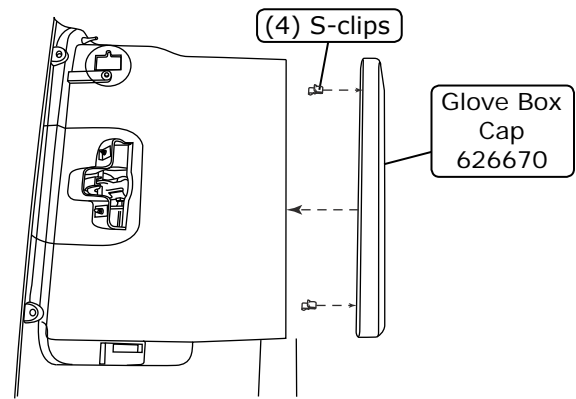
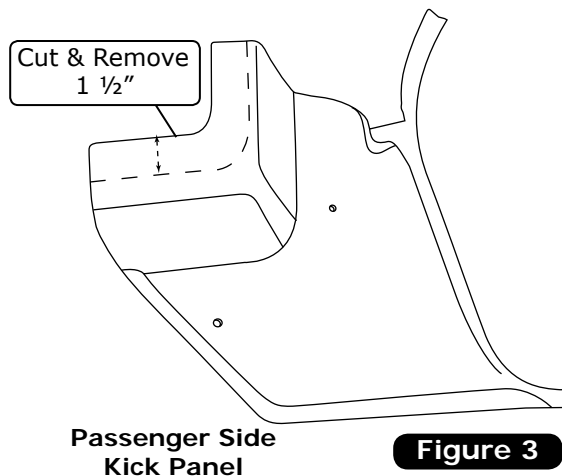

Figure 2



Passenger Side
Kick Panel

Figure 3



Control Panel & Duct Hose Routing

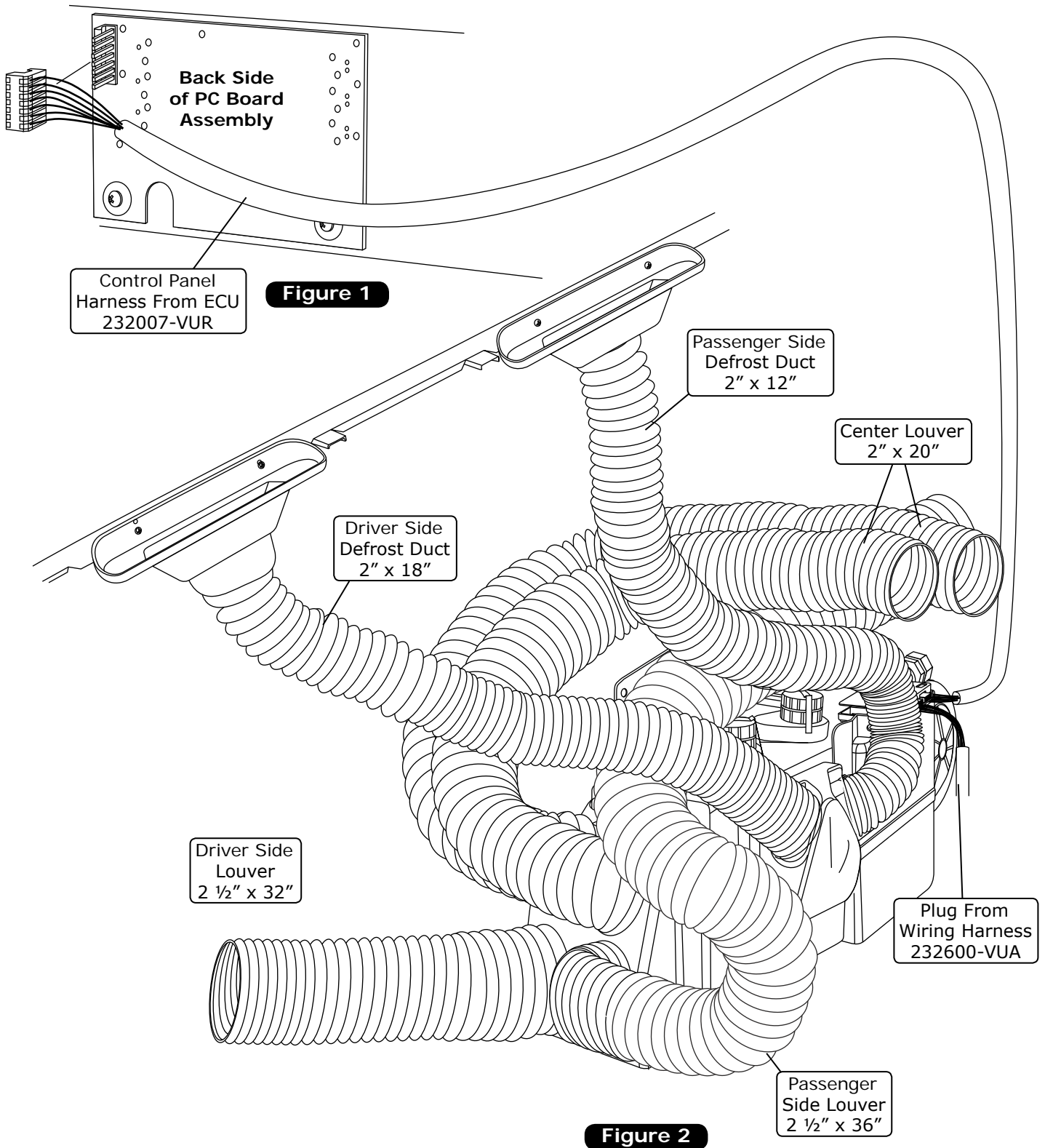



www.vintageair.com

Wiring Diagram

232007-VUR

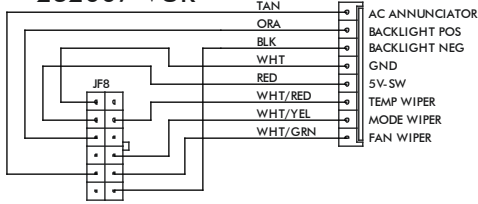

VIEWED FROM WIRE SIDE

232002-VUA

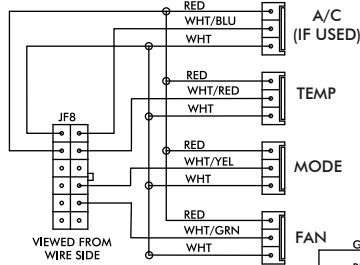

VIEWED FROM WIRE SIDE

PROGRAM

N/A

* DASH LAMP (IF USED)

*** WIDE OPEN THROTTLE SWITCH (OPTIONAL)

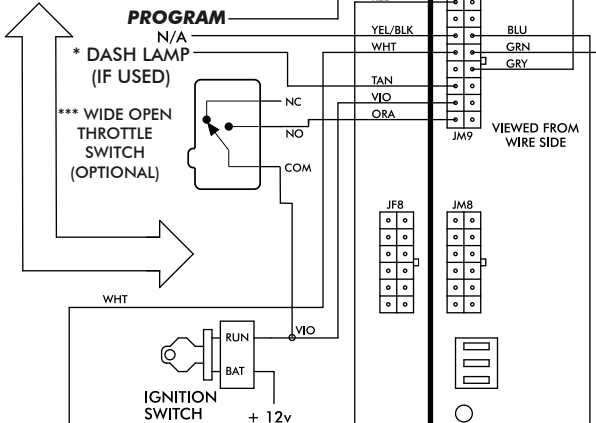

GEN IV ECU

GEN IV WIRING DIAGRAM
REV E, 10/6/2017

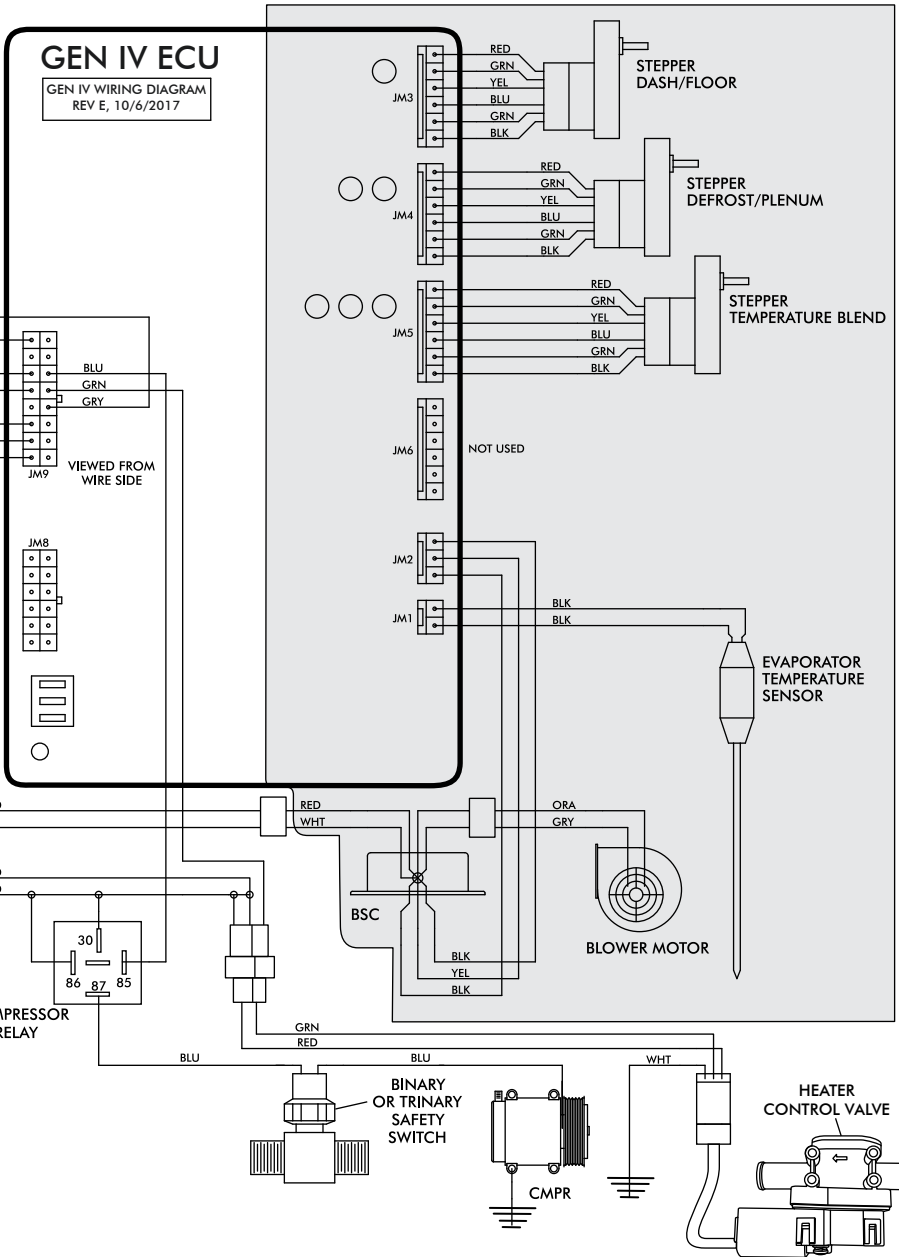

PRE-WIRED

NOTE: = CHASSIS GROUND

* Dash Lamp Is Used Only With Type 232007-VUR Harness.

** Warning: Always Mount Circuit Breaker As Close to the Battery As Possible. (NOTE: Wire Between Battery and Circuit Breaker Is Unprotected and Should Be Carefully Routed to Avoid a Short Circuit).

*** Wide Open Throttle Switch Contacts Close Only at Full Throttle, Which Disables A/C Compressor.



www.vintageair.com

Gen IV Wiring Connection Instruction

WIRING HARNESS

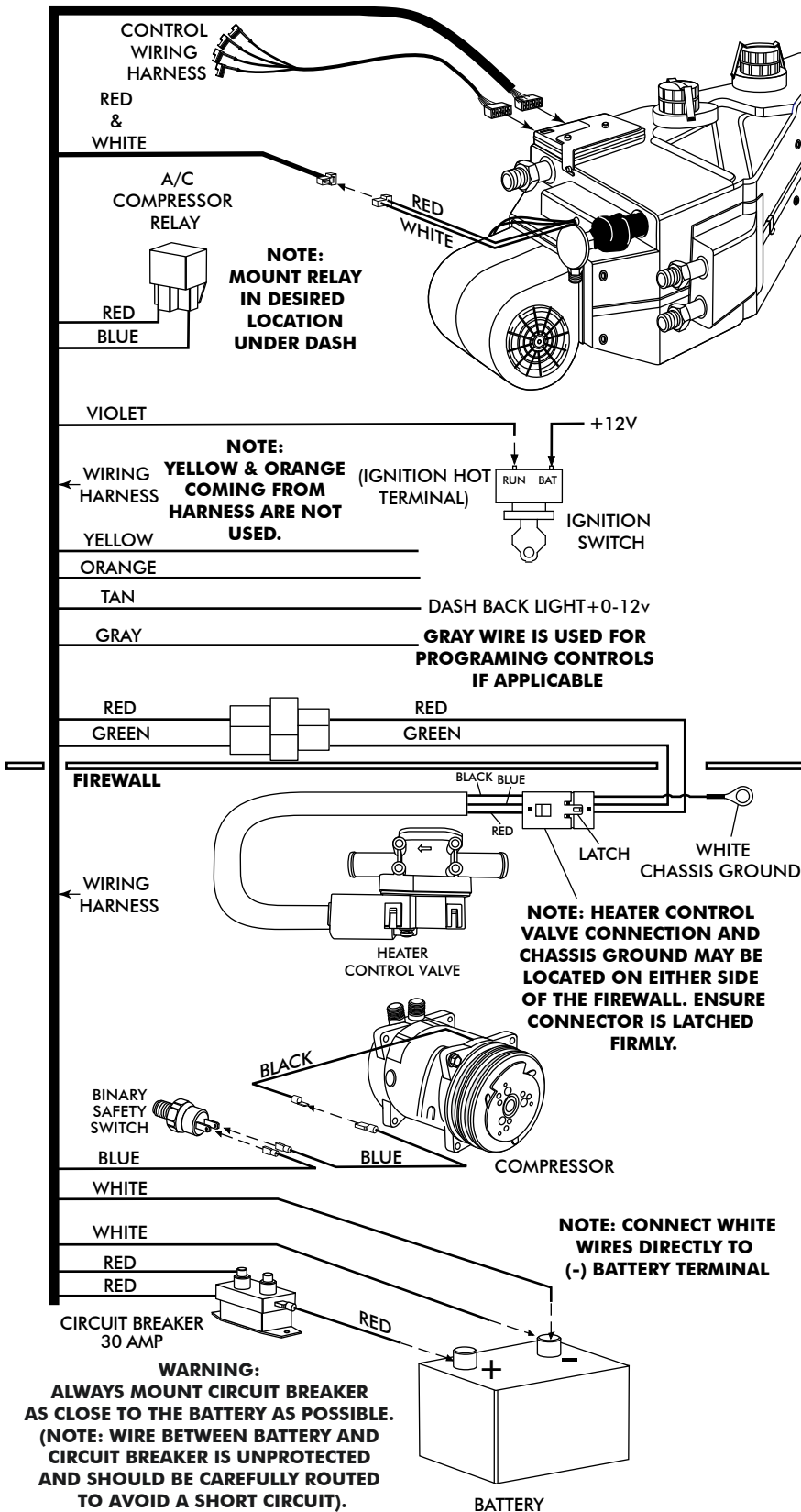

Ignition Switch:
Violet 12V Ign Switch Source (Key On Accessory) Position Must Be Switched.

Dash Light:
Tan Wire Used Only With Vintage Air Supplied Control Panel With LED Back Light.

Heater Control Valve:
Install With Servo Motor Facing Down, As Shown. Note Flow Direction Arrow Molded Into Valve Body, And Install Accordingly.

Binary/Trinary & Compressor:
Binary: Connect As Shown (Typical Compressor Wiring). Be Sure Compressor Body Is Grounded.
Trinary Switch: Connect According To Trinary Switch Wiring Diagram.

Circuit Breaker/Battery:
White **Must** Run To (-) Battery. Red May Run To (+) Battery Or Starter. Mount Circuit Breaker As Close to Battery As Possible.

WARNING:
ALWAYS MOUNT CIRCUIT BREAKER AS CLOSE TO THE BATTERY AS POSSIBLE. (NOTE: WIRE BETWEEN BATTERY AND CIRCUIT BREAKER IS UNPROTECTED AND SHOULD BE CAREFULLY ROUTED TO AVOID A SHORT CIRCUIT).



www.vintageair.com

Operation of Controls

On Gen IV systems with three lever/knob controls, the temperature control toggles between heat and A/C operations. To activate A/C, move the temperature lever/knob all the way to cold and then back it off to the desired vent temperature. For heat operation, move the temperature lever/knob all the way to hot and then adjust to the desired vent temperature. The blower will momentarily change speed, each time you toggle between operations, to indicate the change.

Blower Speed

This lever/knob controls blower speed, from OFF to HI.

Mode Control

This lever/knob controls the mode positions, from DASH to FLOOR to DEFROST, with a blend in between.

Temperature Control

This lever/knob controls the temperature, from HOT to COLD.

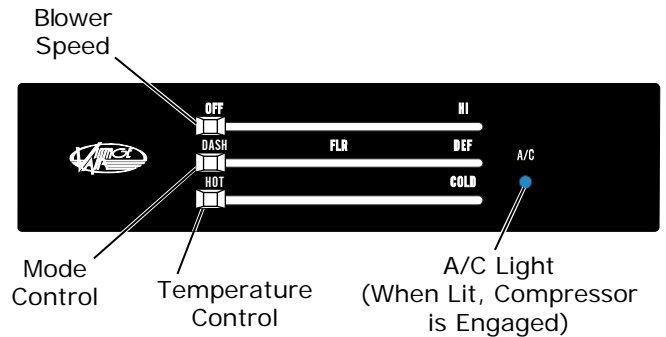

A/C Operation

Blower Speed

Adjust to desired speed.

Mode Control

Adjust to desired mode position (DASH position recommended).

Temperature Control

For A/C operation, adjust to coldest position to engage compressor (Adjust between HOT and COLD to reach desired temperature).



Heat Operation

Blower Speed

Adjust to desired speed.

Mode Control

Adjust to desired mode position (FLOOR position recommended).

Temperature Control

For maximum heating, adjust to hottest position (Adjust between HOT and COLD to reach desired temperature).

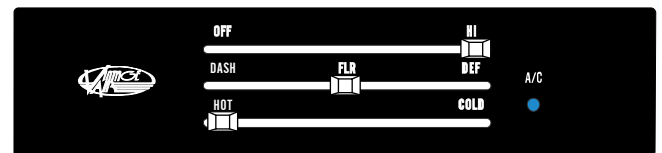

Defrost/De-fog Operation

Blower Speed

Adjust to desired speed.

Temperature Control

Adjust to desired temperature.

Mode Control

Adjust to DEFROST position for maximum defrost, or between FLOOR and DEFROST positions for a bi-level blend (Compressor is automatically engaged).





www.vintageair.com

Troubleshooting Guide

Symptom	Condition	Checks	Actions	Notes
1a. Blower stays on high speed when ignition is on.	No other functions work.	Check for damaged pins or wires in control head plug.	Verify that all pins are inserted into plug. Ensure that no pins are bent or damaged in ECU.	Loss of ground on this wire renders control head inoperable.
	All other functions work.	Check for damaged ground wire (white) in control head harness.	Verify continuity to chassis ground with white control head wire at various points.	See blower switch check procedure.
		Check for damaged blower switch or potentiometer and associated wiring.		
1b. Blower stays on high speed when ignition is on or off.		Unplug 3-wire BSC control connector from ECU. If blower shuts off, ECU is either improperly wired or damaged.	Be sure the small, 20 GA white ground wire is connected to the battery ground post. If it is, replace the ECU.	No other part replacements should be necessary.
		Unplug 3-wire BSC control connector from ECU. If blower stays running, BSC is either improperly wired or damaged.	Check to ensure that no BSC wiring is damaged or shorted to vehicle ground. The BSC operates the blower by ground side pulse width modulation switching. The positive wire to the blower will always be hot. If the "ground" side of the blower is shorted to chassis ground, the blower will run on HI.	
		Replace BSC (This will require removal of evaporator from vehicle).		
2. Compressor will not turn on (All other functions work).	System is not charged.	System must be charged for compressor to engage.	Charge system or bypass pressure switch.	Danger: Never bypass safety switch with engine running. Serious injury can result. To check for proper pot function, check voltage at white/blue wire. Voltage should be between 0V and 5V, and will vary with pot lever position. Disconnected or faulty thermistor will cause compressor to be disabled.
		Check for faulty A/C potentiometer or associated wiring (Not applicable to 3-pot controls).	Check continuity to ground on white control head wire. Check for 5V on red control head wire.	
		Check for disconnected or faulty thermistor.	Check 2-pin connector at ECU housing.	
3. Compressor will not turn off (All other functions work).	System is charged.	Check for faulty A/C potentiometer or associated wiring.	Repair or replace pot/control wiring.	Red wire at A/C pot should have approximately 5V with ignition on. White wire will have continuity to chassis ground. White/Blue wire should vary between 0V and 5V when lever is moved up or down.
		Check for faulty A/C relay.	Replace relay.	



www.vintageair.com

Troubleshooting Guide (Cont.)

Symptom	Condition	Checks	Actions	Notes
4.	Works when engine is not running; shuts off when engine is started (Typically early Gen IV, but possible on all versions).	Noise interference from either ignition or alternator.	Install capacitors on ignition coil and alternator. Ensure good ground at all points. Relocate coil and associated wiring away from ECU and ECU wiring. Check for burned or loose plug wires.	Ignition noise (radiated or conducted) will cause the system to shut down due to high voltage spikes. If this is suspected, check with a quality oscilloscope. Spikes greater than 16V will shut down the ECU. Install a radio capacitor at the positive post of the ignition coil (See radio capacitor installation bulletin). A faulty alternator or worn out battery can also result in this condition.
	System will not turn on, or runs intermittently.	Verify connections on power lead, ignition lead, and both white ground wires.	Check for positive power at heater valve green wire and blower red wire. Check for ground on control head white wire.	
	Will not turn on under any conditions.	Verify battery voltage is greater than 10 volts and less than 16.	Verify proper meter function by checking the condition of a known good battery.	
5.	Loss of mode door function.	Check for damaged mode switch or potentiometer and associated wiring.		Typically caused by evaporator housing installed in a bind in the vehicle. Be sure all mounting locations line up and don't have to be forced into position.
		Check for obstructed or binding mode doors.		
		Check for damaged stepper motor or wiring.		
6.	Blower turns on and off rapidly.	Battery voltage is at least 12V at circuit breaker.	Ensure all system grounds and power connections are clean and tight.	System shuts off blower at 10V. Poor connections or weak battery can cause shutdown at up to 11V.
		Battery voltage is less than 12V.	Charge battery.	
7.	Erratic functions of blower, mode, temp, etc.	Check for faulty battery or alternator.		
		Check for damaged switch or pot and associated wiring.	Repair or replace.	
8.	When ignition is turned on, blower momentarily comes on, then shuts off. This occurs with the blower switch in the OFF position.	This is an indicator that the system has been reset. Be sure the red power wire is on the battery post, and not on a switched source. Also, if the system is pulled below 7V for even a split second, the system will reset.	Run red power wire directly to battery.	



Packing List: Evaporator Kit (565071)

No.	Qty.	Part No.	Description
1.	1	762169	Gen IV Evaporator Sub Case
2.	1	784172	Accessory Kit

Checked By: _____
 Packed By: _____
 Date: _____

1

Gen IV Evaporator
Sub Case
762169

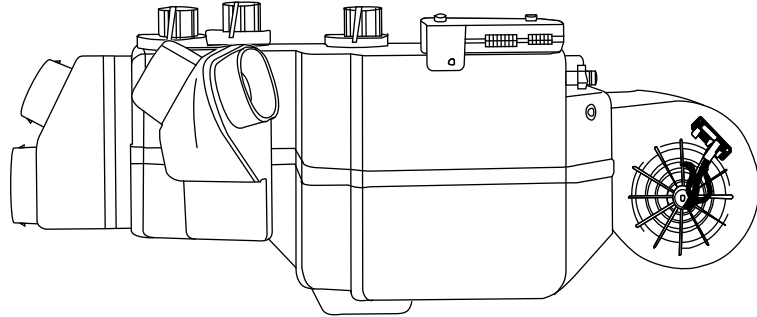

2

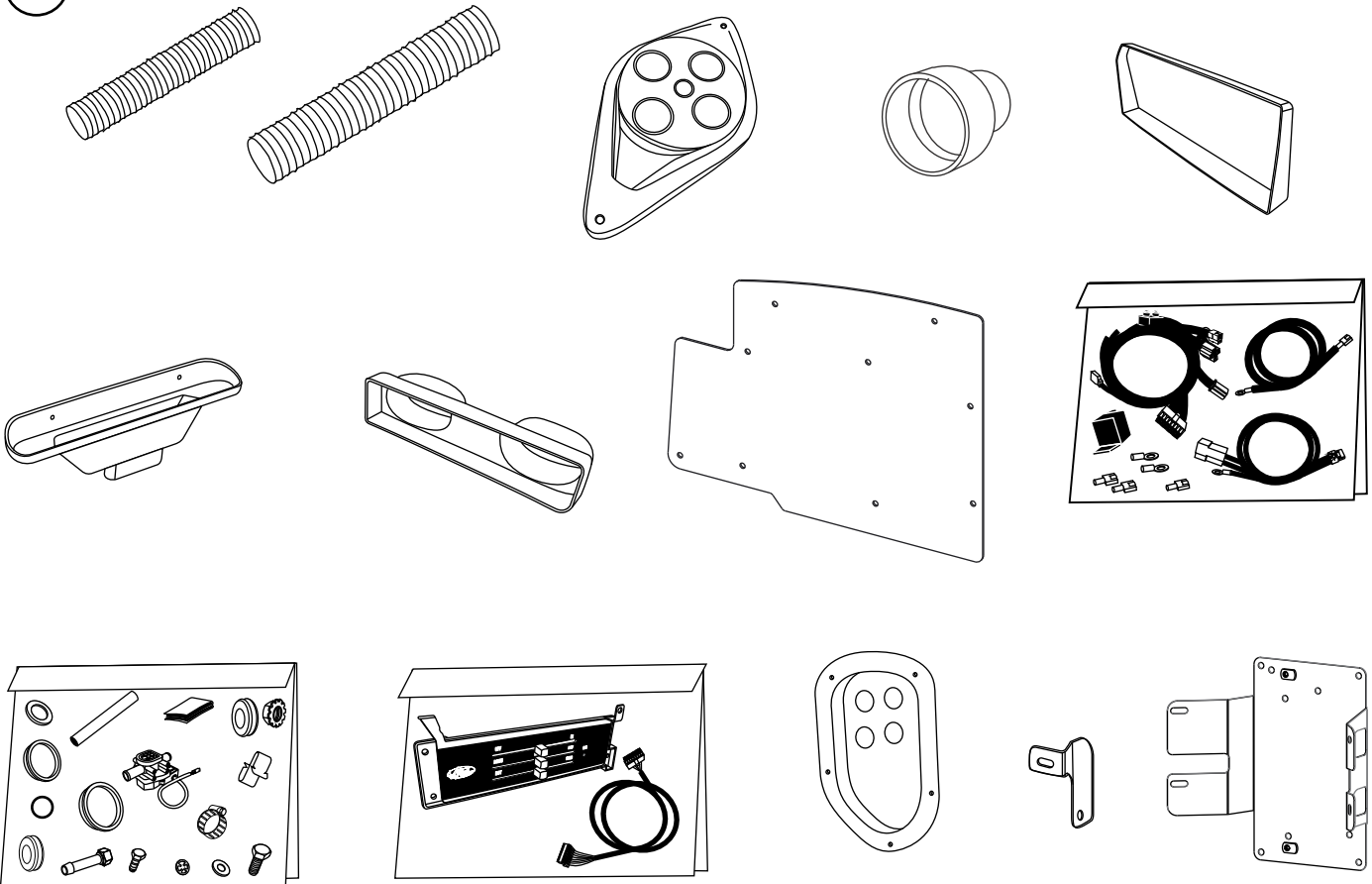

Accessory Kit
784172

**NOTE: Images may not depict actual parts and quantities.
 Refer to packing list for actual parts and quantities.**