



an ISO 9001: 2015 Registered Company

1964-67 PONTIAC GTO

WITH FACTORY AIR

564467

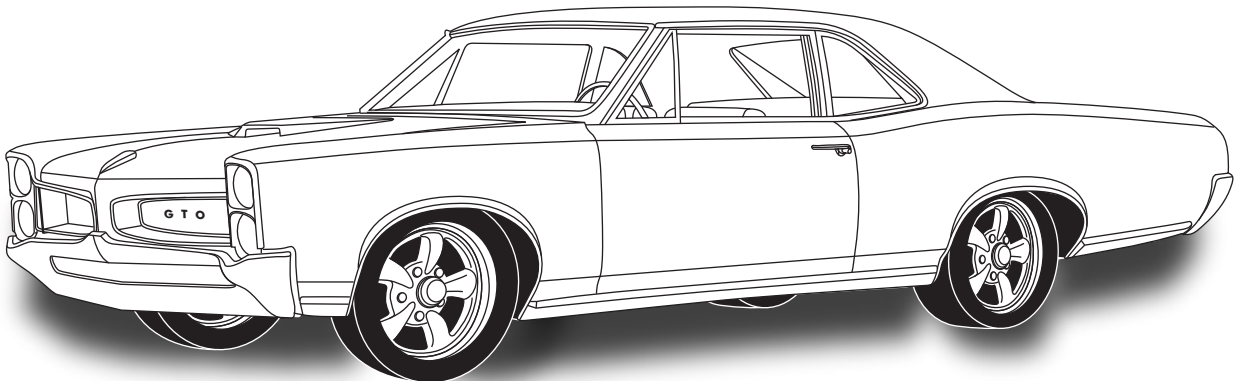

18865 Goll St. San Antonio, TX 78266

Phone: 800-862-6658

Sales: sales@vintageair.com

Tech Support: tech@vintageair.com

www.vintageair.com



Table of Contents

PAGES

1. COVER
2. TABLE OF CONTENTS
3. PACKING LIST / PARTS DISCLAIMER
4. INFORMATION PAGE
5. WIRING NOTICE
6. ENGINE COMPARTMENT
FIGURE 1
7. CONDENSER ASSEMBLY, COMPRESSOR & BRACKET, PULLEYS PASSENGER COMPARTMENT
FIGURES 2 & 2a
8. DEFROST DUCT INSTALLATION & HOSE ADAPTER INSTALLATION
FIGURES 4, 5 & 5a
9. FIREWALL COVER INSTALLATION & EVAPORATOR INSTALLATION
FIGURES 6 & 7
10. BRACKET INSTALLATION
FIGURE 8
11. FRESH AIR COVER INSTALLATION & KICK PANEL FRESH AIR CAP INSTALLATION
FIGURES 9, 10, 10a & 10b
12. EVAPORATOR INSTALLATION CONT.
FIGURES 11 & 12
13. DRAIN HOSE INSTALLATION, LUBRICATING O-RINGS, A/C HOSE INSTALLATION, &
MODIFIED A/C HOSE KIT
FIGURES 13 & 14
14. AC & HEATER HOSE ROUTING
FIGURE 15
15. FINAL STEPS
FIGURES 16, 17 & 18
16. OEM UNDER DASH LOUVER HOSE ADAPTER INSTALLATION
FIGURE 19
17. CONTROL PANEL & DUCT HOSE ROUTING
FIGURE 19
18. WIRING DIAGRAM
19. GEN IV WIRING CONNECTION INSTRUCTIONS
20. (64 GTO) OPERATION OF CONTROLS
21. (65-67 GTO) OPERATION OF CONTROLS
22. TROUBLE SHOOTING INFORMATION
23. TROUBLE SHOOTING INFORMATION CONT.
24. EVAPORATOR KIT PACKING LIST



EVAPORATOR KIT PACKING LIST

EVAPORATOR KIT
564467

NO.	QTY.	PART NO.	DESCRIPTION
1.	1	744002	GEN IV 6-VENT EVAPORATOR SUB CASE with 204 ECU
2.	1	784158	1964-67 GTO with A/C ACCESSORY KIT

**** BEFORE BEGINNING INSTALLATION OPEN ALL PACKAGES AND CHECK CONTENTS OF SHIPMENT. PLEASE REPORT ANY SHORTAGES DIRECTLY TO VINTAGE AIR WITHIN 15 DAYS. AFTER 15 DAYS, VINTAGE AIR WILL NOT BE RESPONSIBLE FOR MISSING OR DAMAGED ITEMS.**

①

**GEN IV 6-VENT
EVAPORATOR SUB CASE
with 204 ECU
744002**

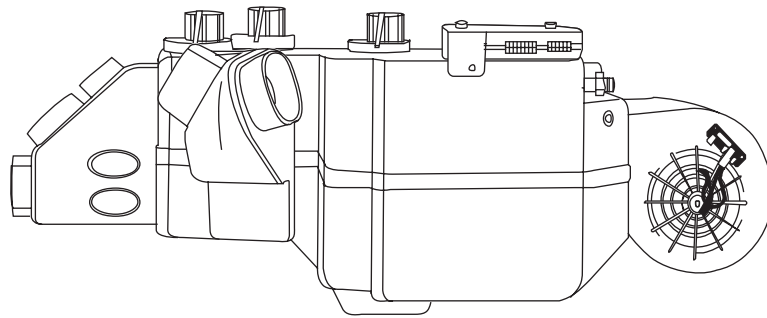

②

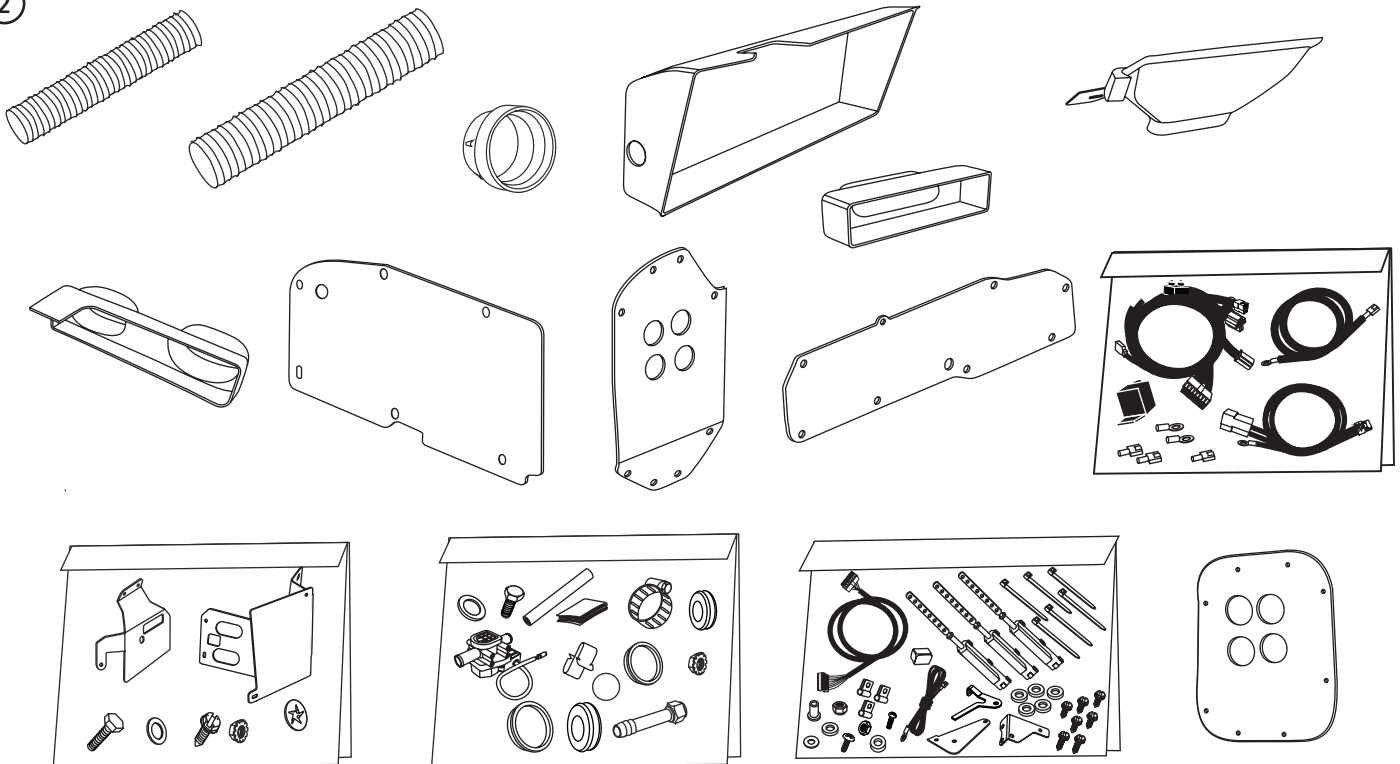

**ACCESSORY KIT
784158**

NOTE: IMAGES MAY NOT DEPICT ACTUAL PARTS AND QUANTITIES. REFER TO PACKING LIST FOR ACTUAL PARTS AND QUANTITIES.

3



Important Notice—Please Read

For Maximum System Performance, Vintage Air Recommends the Following:

NOTE: Vintage Air systems are designed to operate with R134a refrigerant only. Use of any other refrigerant could damage your A/C system and/or vehicle, and possibly cause a fire, in addition to potentially voiding the warranties of the A/C system and its components.

Refrigerant Capacities:

Vintage Air System: 1.8 lbs. (1 lb., 12 oz.) of **R134a**, charged by weight with a quality charging station or scale. **NOTE: Use of the proper type and amount of refrigerant is critical to system operation and performance.**

Other Systems: Consult manufacturer's guidelines.

Lubricant Capacities:

New Vintage Air-supplied Sanden Compressor: No additional oil needed (Compressor is shipped with proper oil charge).

All Other Compressors: Consult manufacturer (Some compressors are shipped dry and will need oil added).

Safety Switches

Your Vintage Air system is equipped with a binary pressure safety switch. A binary switch disengages the compressor clutch in cases of extreme low pressure conditions (Refrigerant Loss) or excessively high head pressure (406 PSI) to prevent compressor damage or hose rupture. A trinary switch combines Hi/Lo pressure protection with an electric fan operation signal at 254 PSI, and should be substituted for use with electric fans. Compressor safety switches are extremely important since an A/C system relies on refrigerant to circulate lubricant.

Service Info:

Protect Your Investment: Prior to assembly, it is critical that the compressor, evaporator, A/C hoses and fittings, hardlines, condenser and receiver/drier remained capped. Removing caps prior to assembly will allow moisture, insects and debris into the components, possibly leading to reduced performance and/or premature failure of your A/C system. This is especially important with the receiver/drier.

Additionally, when caps are removed for assembly, **BE CAREFUL!** Some components are shipped under pressure with dry nitrogen.

Evacuate the System for 35-45 Minutes: Ensure that system components (Drier, compressor, evaporator and condenser) are at a temperature of at least 85° F. On a cool day, the components can be heated with a heat gun **or** by running the engine with the heater on before evacuating. Leak check and charge to specifications.

Bolts Passing Through Cowl and/or Firewall:

To ensure a watertight seal between the passenger compartment and the vehicle exterior, for all bolts passing through the cowl and/or firewall, Vintage Air recommends coating the threads with silicone prior to installation.

Heater Hose (Not Included With This Kit):

Heater hose may be purchased from Vintage Air (Part# 31800-VUD) or your local parts retailer. Routing and required length will vary based on installer preference.



Important Wiring Notice—Please Read

Some Vehicles May Have Had Some or All of Their Radio Interference Capacitors Removed. There Should Be a Capacitor Found At Each of the Following Locations:

- 1. On the positive terminal of the ignition coil.**
- 2. If there is a generator, on the armature terminal of the generator.**
- 3. If there is a generator, on the battery terminal of the voltage regulator.**

Most alternators have a capacitor installed internally to eliminate what is called “whining” as the engine is revved. If whining is heard in the radio, or just to be extra cautious, a radio interference capacitor can be added to the battery terminal of the alternator.

It is also important that the battery lead is in good shape and that the ground leads are not compromised. There should be a heavy ground from the battery to the engine block, and additional grounds to the body and chassis.

If these precautions are not observed, it is possible for voltage spikes to be present on the battery leads. These spikes come from ignition systems, charging systems, and from switching some of the vehicle’s other systems on and off. Modern computer-operated equipment can be sensitive to voltage spikes on the power leads, which can cause unexpected resets, strange behavior, and/or permanent damage.

Vintage Air strives to harden our products against these types of electrical noise, but there is a point where a vehicle’s electrical system can be degraded so much that nothing can help.

Radio interference capacitors should be available at most auto and truck parts suppliers. They typically are cylindrical in shape, a little over an inch long, a little over a half inch in diameter, and they have a single lead coming from one end of the cylinder with a terminal on the end of the wire, as well as a mounting clip which is screwed into a good ground on the vehicle. The specific value of the capacitance is not too significant in comparison to ignition capacitors that are matched with the coil to reduce pitting of the points.

- Care must be taken, when installing the compressor lead, not to short it to ground. The compressor lead must not be connected to a condenser fan or to any other auxiliary device. Shorting to ground or connecting to a condenser fan or any other auxiliary device may damage wiring, the compressor relay, and/or cause a malfunction.
- When installing ground leads on Gen IV systems, the blower control ground and ECU ground must be connected directly to the negative battery post.
- For proper system operation, the heater control valve must be connected to the ECU.



BEFORE STARTING THE INSTALLATION, CHECK THE FUNCTION OF THE VEHICLE (HORN, LIGHTS, ETC.) FOR PROPER OPERATIONS. STUDY THE INSTRUCTIONS, ILLUSTRATIONS, & DIAGRAMS.

ENGINE COMPARTMENT

REMOVE THE FOLLOWING

- DRAIN RADIATOR, REMOVE RADIATOR (RETAIN).
- EVACUATE THE A/C SYSTEM IF NECESSARY.
- OEM CONDENSER AND DRIER (DISCARD). SEE FIGURE 1.
- OEM A/C LINES FROM COMPRESSOR TO EVAPORATOR (DISCARD). SEE FIGURE 1.
- OEM COMPRESSOR AND BRACKET (DISCARD). SEE FIGURE 1.
- EVAPORATOR BLOWER ASSEMBLY (DISCARD).

TO REMOVE THE EVAPORATOR AND BLOWER ASSEMBLY (UNDER HOOD) AND THE AIR DISTRIBUTION SYSTEM (UNDER DASH), THE FACTORY MANUAL INDICATES DOING THE FOLLOWING: **REMOVE RIGHT INNER FENDER.**

- OEM HEATER HOSES, A/C HOSES, AND HARDLINES (DISCARD). SEE FIGURE 1.
- OEM A/C & HEATER WIRING/VACUUM HARNESS MOLDED GROMMET. SEE FIGURE 1.

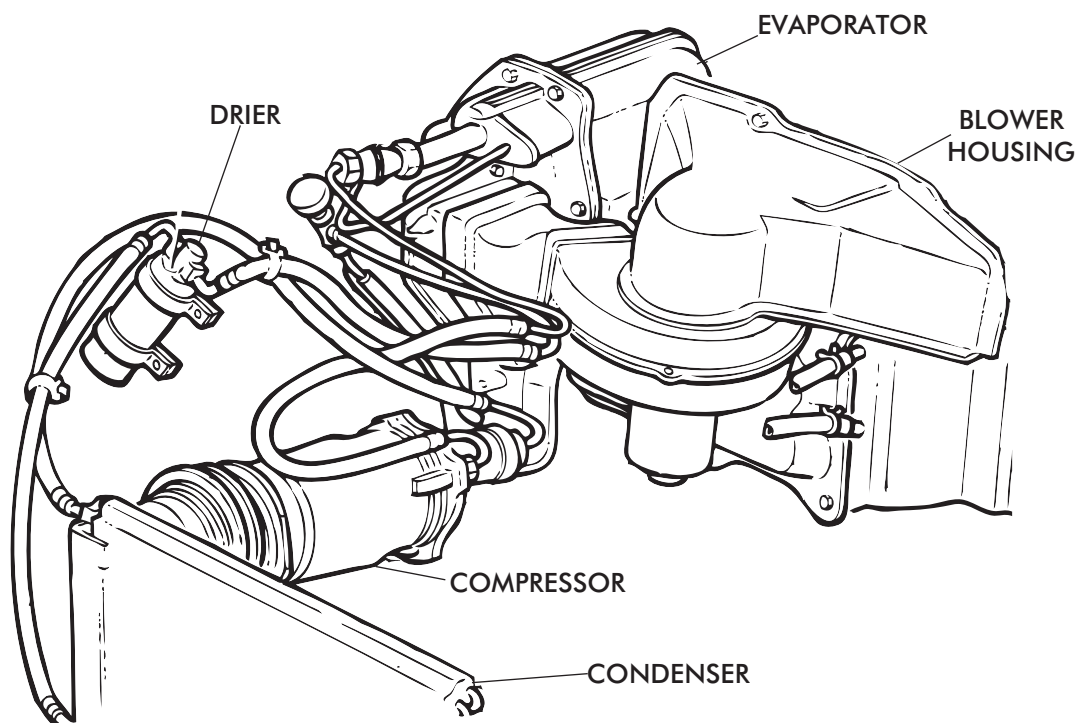

FIGURE 1



CONDENSER ASSEMBLY & INSTALLATION

- REFER TO SEPARATE INSTRUCTIONS INCLUDED WITH THE CONDENSER KIT TO INSTALL THE CONDENSER.
- BINARY SWITCH INSTALLATION (REFER TO CONDENSER INSTRUCTIONS).

COMPRESSOR & BRACKETS

- REFER TO SEPARATE INSTRUCTIONS INCLUDED WITH THE BRACKET KIT TO INSTALL THE COMPRESSOR BRACKET.

PASSENGER COMPARTMENT

REMOVE THE FOLLOWING:

- REMOVE GLOVE BOX DOOR (RETAIN) AND GLOVE BOX (DISCARD).
- DISCONNECT ALL WIRE AND CABLES FROM CONTROL PANEL AND RADIO.
- ALL HOSE AND DUCTING FROM O.E.M LOUVERS, SEE FIGURE 2 BELOW.
- OEM DEFROST DUCT ASSEMBLY, SEE BELOW.
- OEM AC/ HEATER ASSEMBLY. SEE BELOW.
- PASSENGER SIDE KICK PANEL/FRESH AIR DOOR ASM AS SHOWN IN FIGURES 2 & 2a.

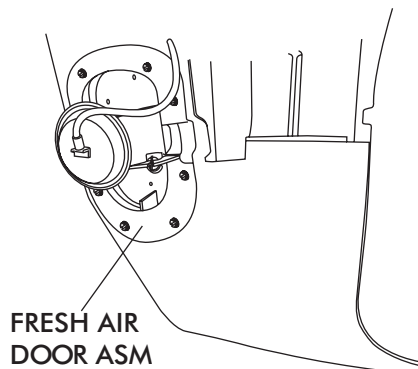
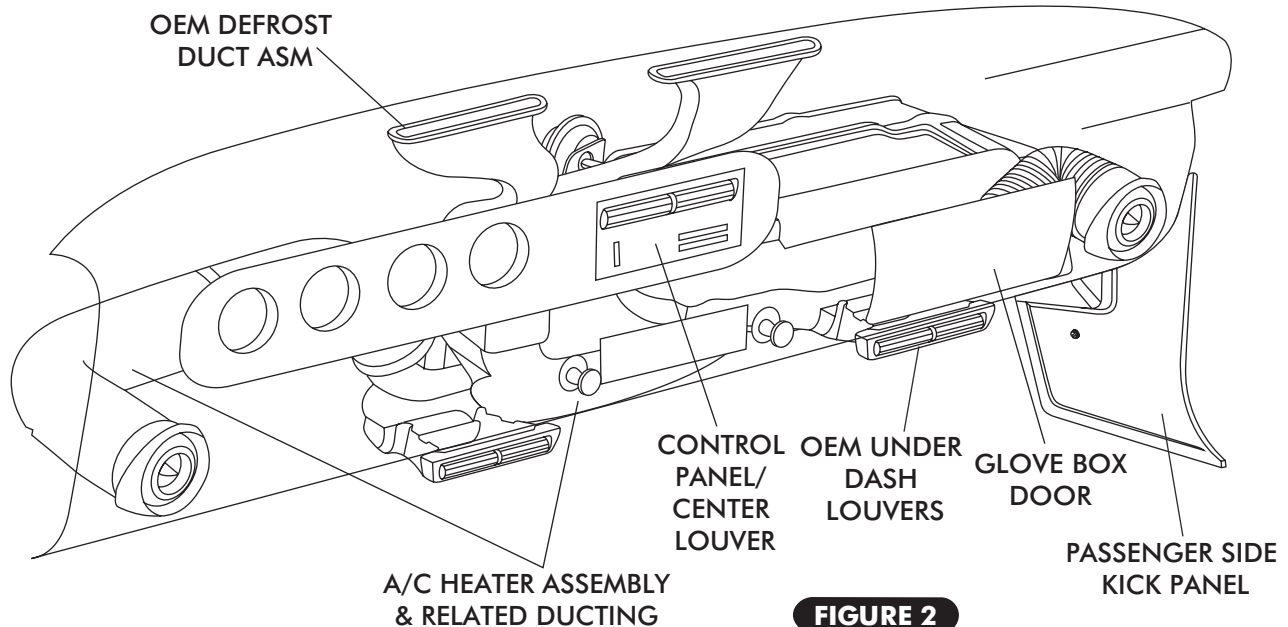



DEFROST DUCT INSTALLATION

- INSTALL DEFROST DUCTS UNDER DASH AND ALIGN WITH OEM OPENING.
- INSTALL THE DRIVER AND PASSENGER SIDE DEFROST DUCT ASM TO COWL USING (2) #10 x 1/2" HEX SHEET METAL SCREWS.
- NOTE: APPLY SILICONE ON SCREWS TO ENSURE LEAK FREE INSTALLATION. SEE FIGURE 4 BELOW.**

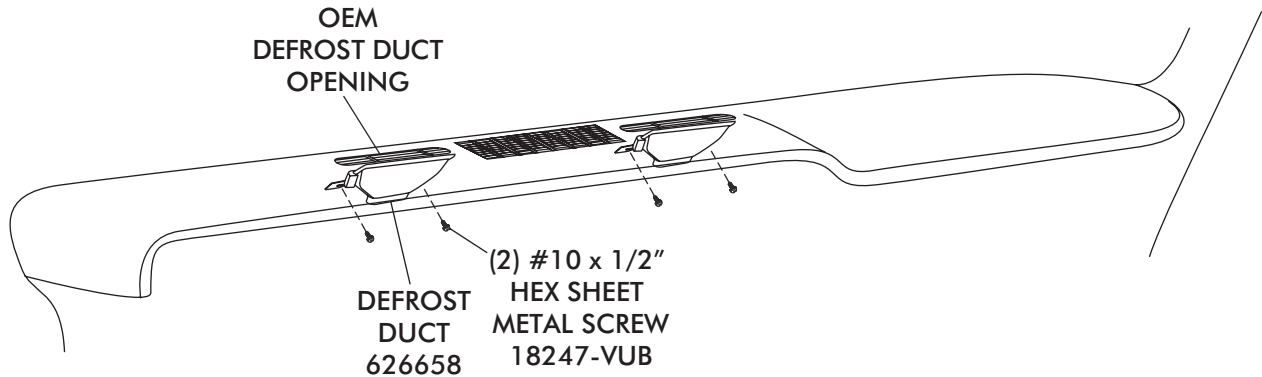

FIGURE 4

HOSE ADAPTER INSTALLATION

- INSTALL (3) S-CLIPS ON DRIVER SIDE/PASSENGER SIDE LOUVER HOSE ADAPTER AS SHOWN IN FIGURE 5 BELOW.
- INSTALL DRIVER & PASSENGER SIDE HOSE ADAPTERS OUTSIDE OEM LOUVERS.
- INSTALL S-CLIPS ON CENTER LOUVER HOSE ADAPTER AS SHOWN IN FIGURE 5a BELOW.
- INSTALL CENTER LOUVER HOSE ADAPTER INSIDE OEM CENTER LOUVER.
- REINSTALL DRIVER & PASSENGER SIDE LOUVERS IN DASH.

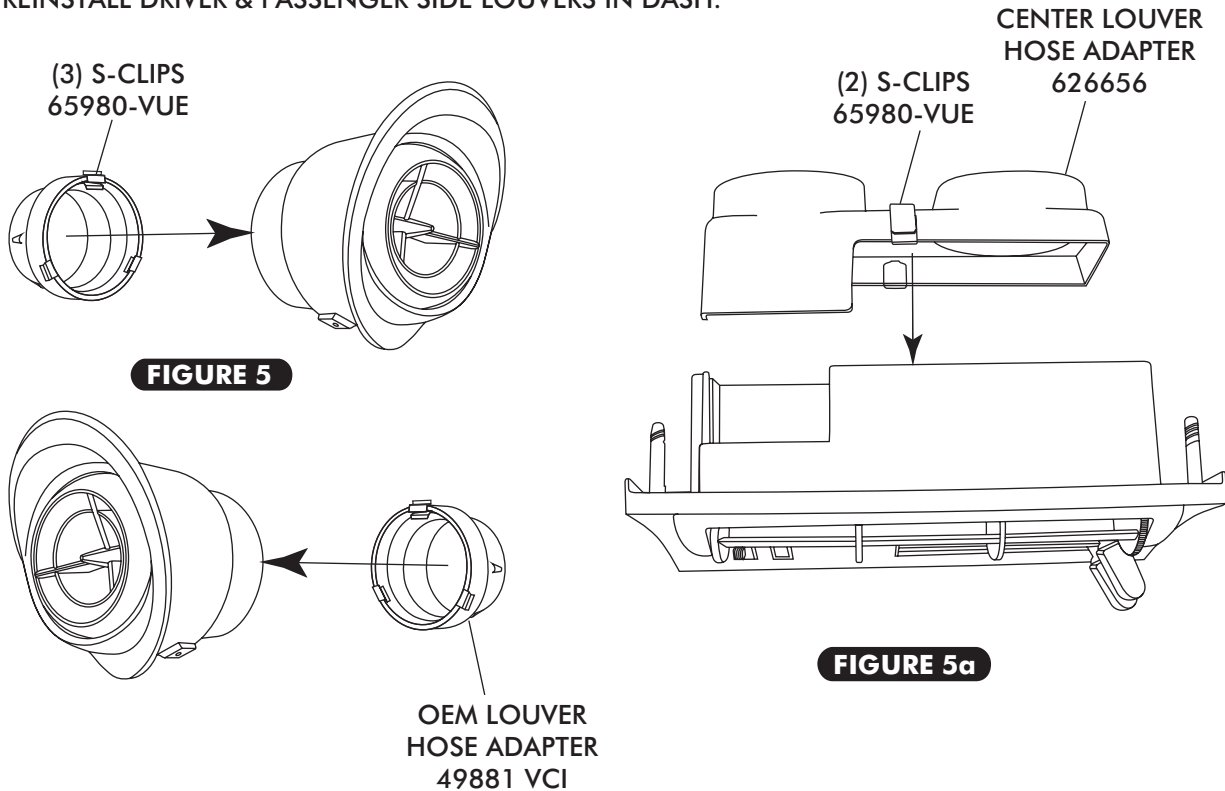

FIGURE 5

FIGURE 5a



FIREWALL COVER INSTALLATION

- APPLY A 1/4" BEAD OF SILICONE AROUND THE BACK SIDE OF THE FIREWALL COVER AS SHOWN IN FIGURE 6, BELOW.
- FROM INSIDE THE CAR, INSTALL FIREWALL COVER ON FIREWALL USING (3) 1/4-20 x 1" HEX BOLTS, FLAT WASHERS AND 1/4-20 NUTS WITH STAR WASHERS, SEE FIGURE 6, BELOW.

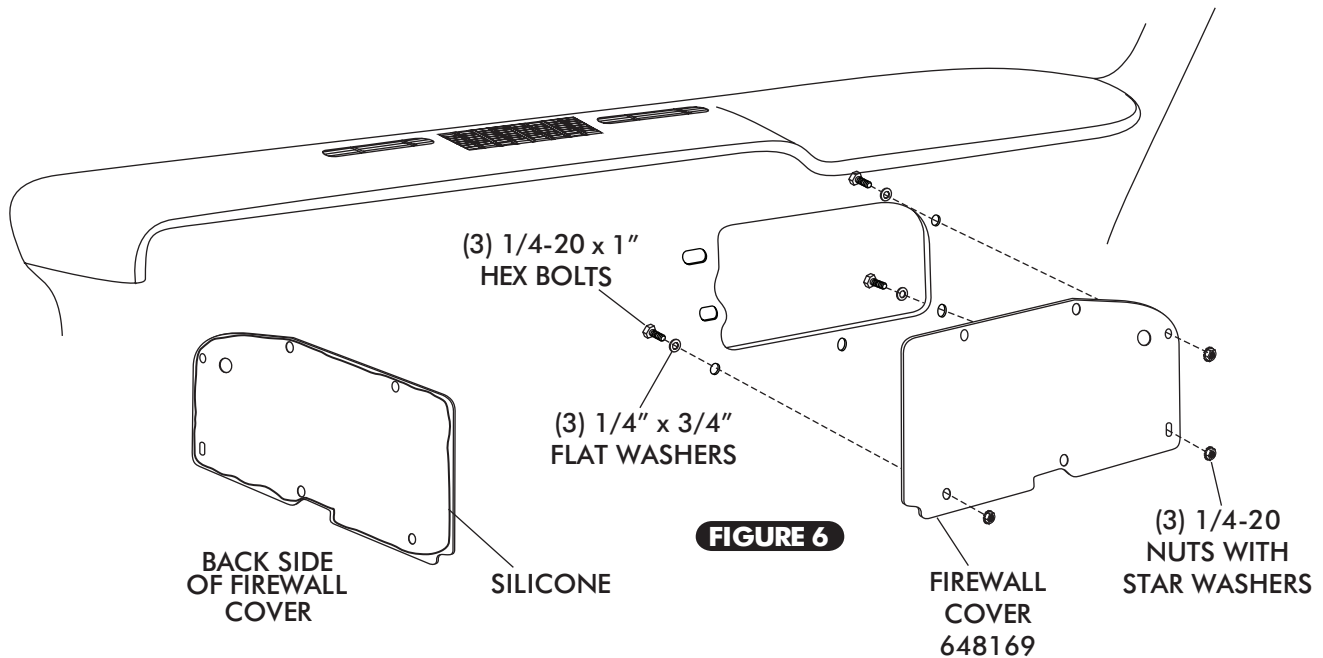

FIGURE 6

EVAPORATOR INSTALLATION

- ON A WORK BENCH INSTALL (2) HEATER FITTINGS WITH PROPERLY LUBRICATED O-RINGS. (SEE FIGURE 14, PAGE 13, AND FIGURE 8 PAGE 10.)
- INSTALL (2) HEX BOLTS, (2) NYLON SPACERS AND (2) 1/4" PUSH NUT BOLT RETAINERS ON EVAP REAR BRKT AS SHOWN IN FIGURE 8, PAGE 10.
- INSTALL EVAPORATOR FRONT & REAR MOUNTING BRACKETS ON EVAPORATOR USING (6) 1/4-20 x 1/2" HEX BOLTS AND TIGHTEN AS SHOWN IN FIGURE 7 BELOW & FIGURE 8, PAGE 10.
- LAY EVAPORATOR SUB CASE ON PASSENGER SIDE FLOOR BOARD. INSTALL A/C & HEATER HOSE ON EVAPORATOR AS SHOWN IN FIGURE 11, PAGE 12 AND HOSE INSTALLATION ON PAGE 14.
- **NOTE: WRAP THE #10 FITTING CONNECTIONS WITH PRESS TAPE. SEE FIGURE 11, PAGE 12.**

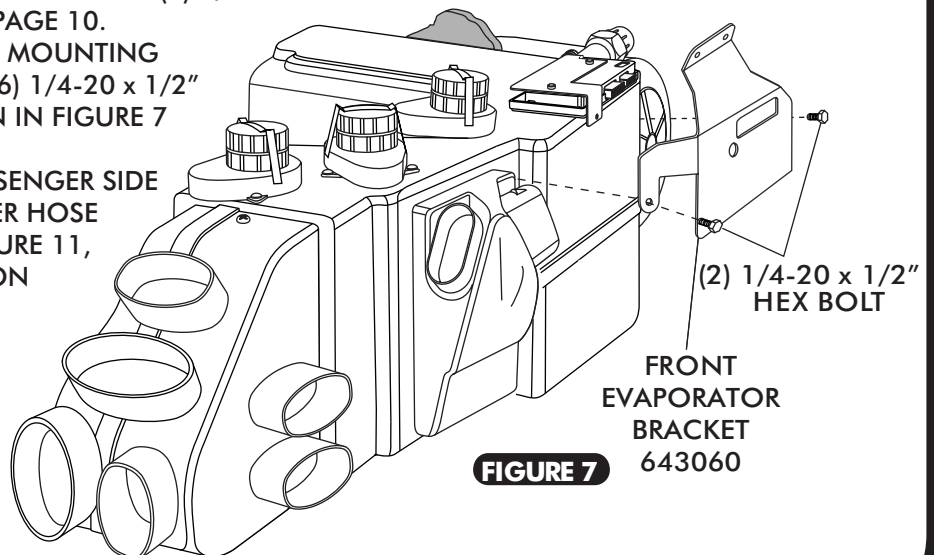
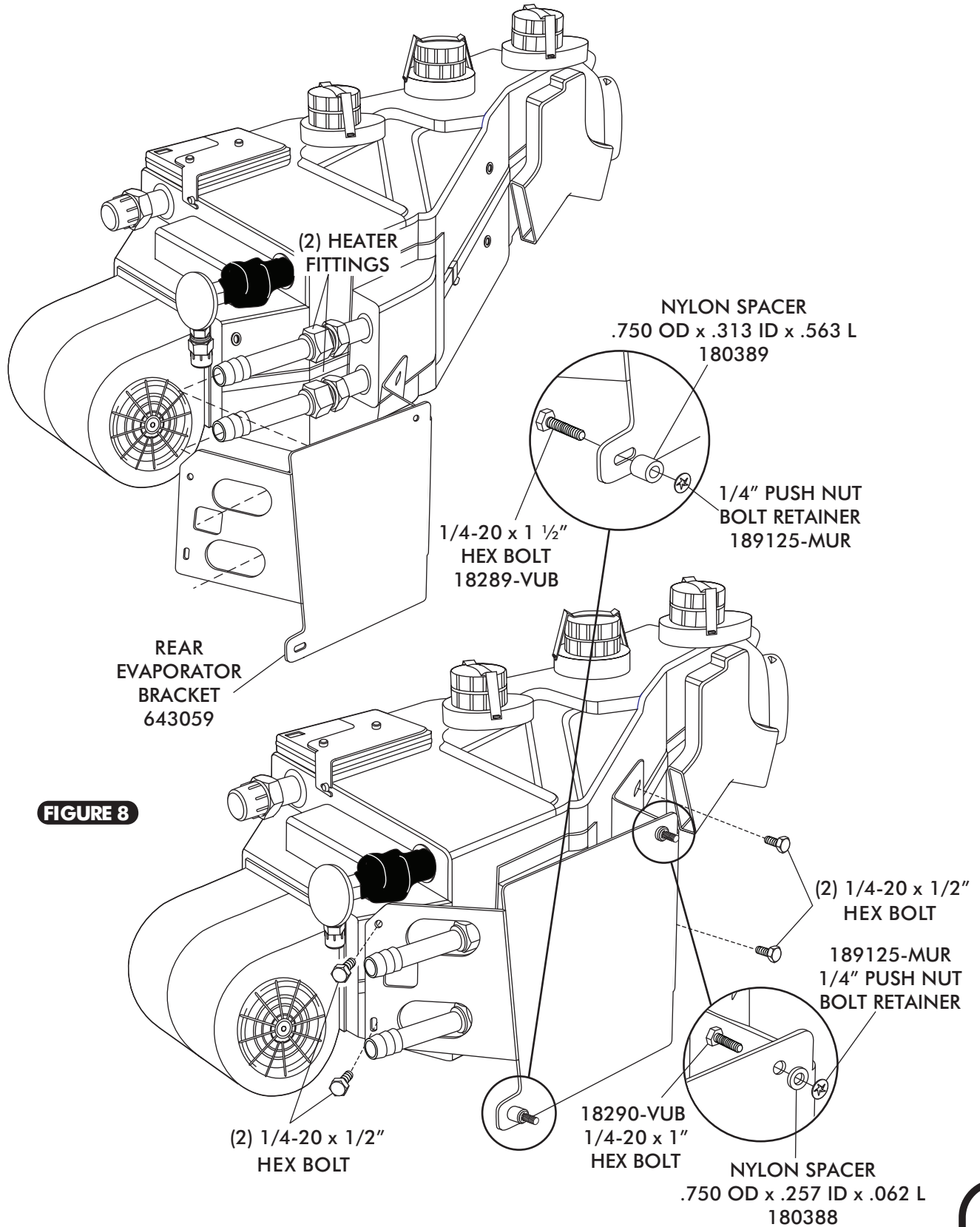

FIGURE 7



BRACKET INSTALLATION





A/C BLOCK OFF PLATE/HEATER BLOWER COVER INSTALLATION

- ❑ INSTALL (4) GROMMETS IN A/C BLOCK-OFF PLATE AS SHOWN IN FIGURE 9 BELOW.
- ❑ APPLY A 1/4" BEAD OF SILICONE AROUND THE BACK SIDE OF THE A/C BLOCK-OFF PLATE AS SHOWN IN FIGURE 9 BELOW.
- ❑ INSTALL THE A/C BLOCK-OFF PLATE USING (8) #14 x 3/4" HEX SHEET METAL SCREWS AS SHOWN IN FIGURE 9 BELOW.
- ❑ APPLY A 1/4" BEAD OF SILICONE AROUND THE BACK SIDE OF THE HEATER/BLOWER COVER AS SHOWN IN FIGURE 9 BELOW.
- ❑ INSTALL THE HEATER/BLOWER COVER USING (4) #14 x 3/4" HEX SHEET METAL SCREWS, SHOWN IN FIGURE 9.
- ❑ DRILL (2) 3/16" AND (2) 5/16" HOLES IN FIREWALL USING THE HEATER BLOWER COVER AS TEMPLATE. INSTALL (2) #14 x 3/4" HEX SHEET METAL SCREWS AND (1) 1/4 - 20 x 1" BOLT w/ FLAT WASHER AND 1/4" NUT w/ STAR WASHER. SEE FIGURE 9, BELOW.

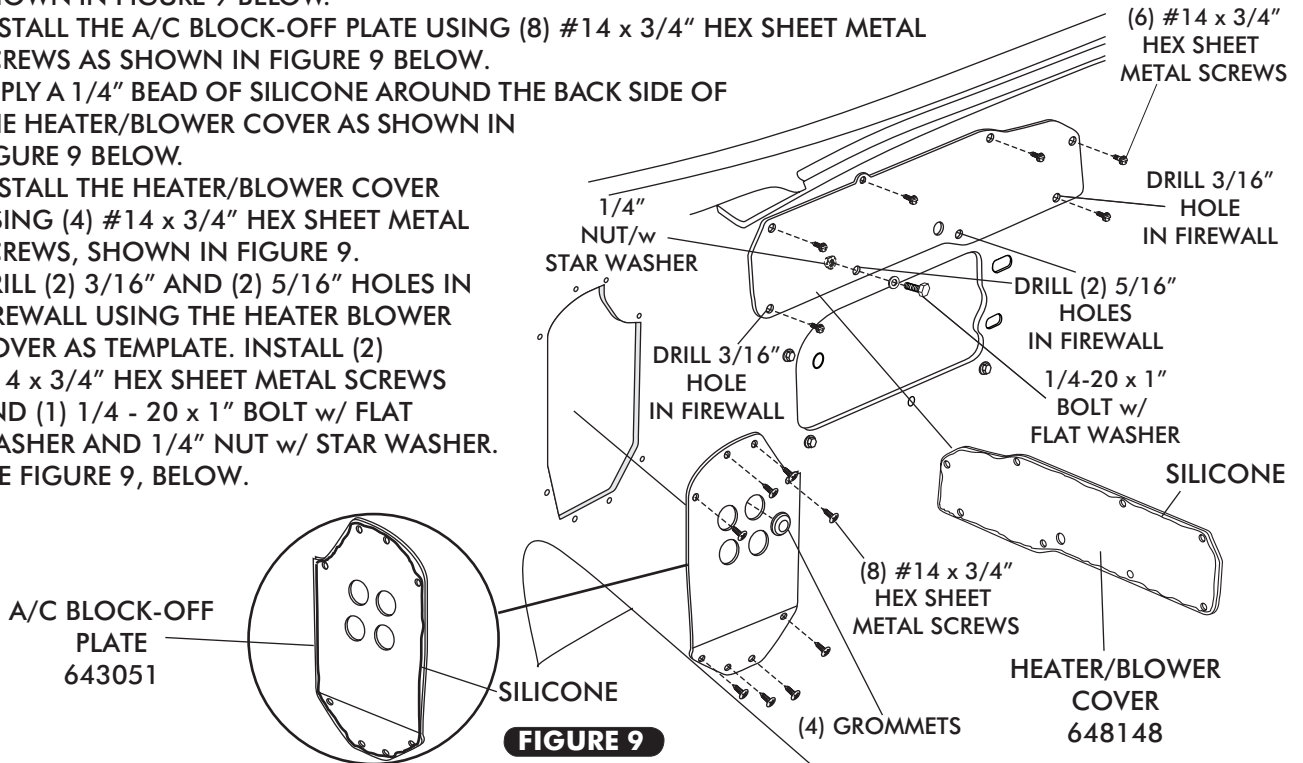

FIGURE 9

KICK PANEL FRESH AIR CAP INSTALLATION

- ❑ INSTALL (4) GROMMETS IN KICK PANEL FRESH AIR CAP, SEE FIGURE 10a BELOW.
- ❑ ROUTE A/C AND HEATER HOSE THROUGH A/C BLOCK-OFF PLATE AND KICK PANEL FRESH AIR CAP AS SHOWN IN FIGURE 10 AND 10b, BELOW.
- ❑ APPLY A 1/4" BEAD OF SILICONE AROUND THE BACK SIDE OF KICK PANEL FRESH AIR CAP AS SHOWN IN FIGURE 10a, BELOW.
- ❑ SECURE KICK PANEL FRESH AIR CAP USING (8) #8 x 1 1/4" PH PAN HEAD SCREWS, AS SHOWN IN FIGURE 10b BELOW.

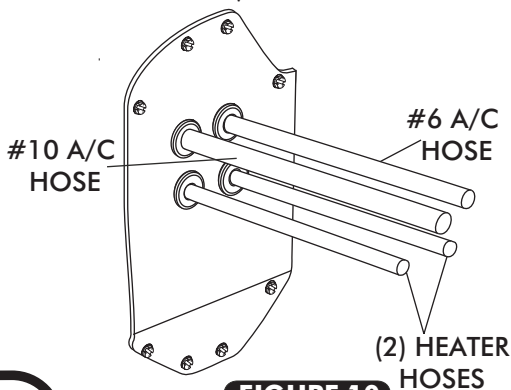

FIGURE 10

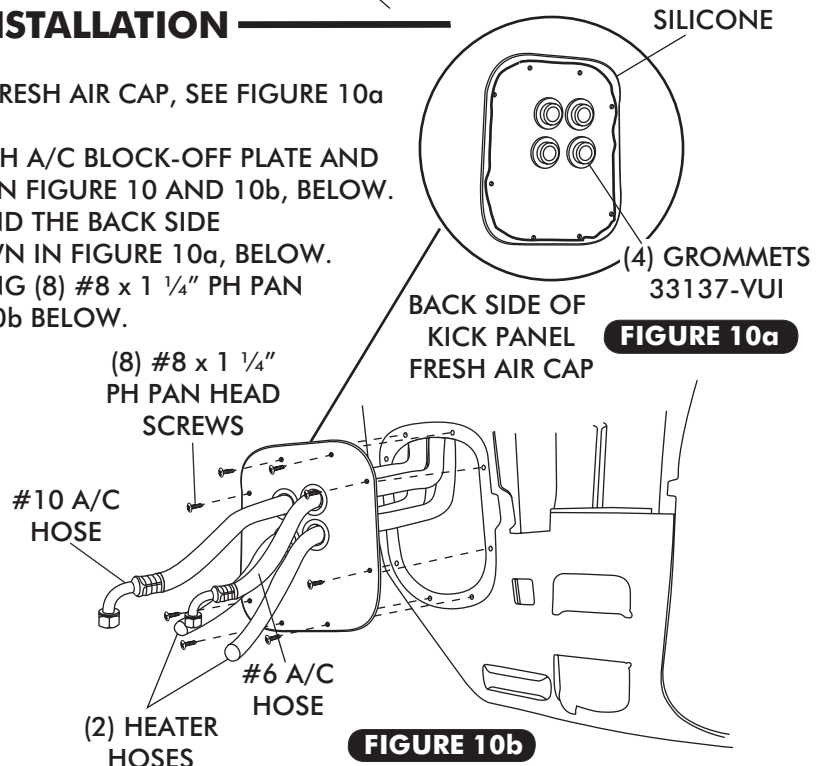

FIGURE 10a

FIGURE 10b



EVAPORATOR INSTALLATION CONT.

- LIFT EVAPORATOR UNIT UP UNDER THE DASHBOARD. SECURE LOOSELY TO THE FIREWALL FROM THE ENGINE COMPARTMENT SIDE USING (2) 1/4-20 NUTS AND FLAT WASHERS, SEE FIGURE 12.
- SECURE THE FRONT EVAPORATOR MOUNTING BRACKET TO COWL USING (2) #14 x 3/4" HEX SHEET METAL SCREWS. SEE FIGURE 12 BELOW.
- VERIFY THAT EVAPORATOR UNIT IS LEVEL AND SQUARE TO THE DASH, THEN TIGHTEN ALL MOUNTING BOLTS. **NOTE: TIGHTEN THE BOLT ON FIREWALL FIRST, THEN THE FRONT MOUNTING BRACKET.**

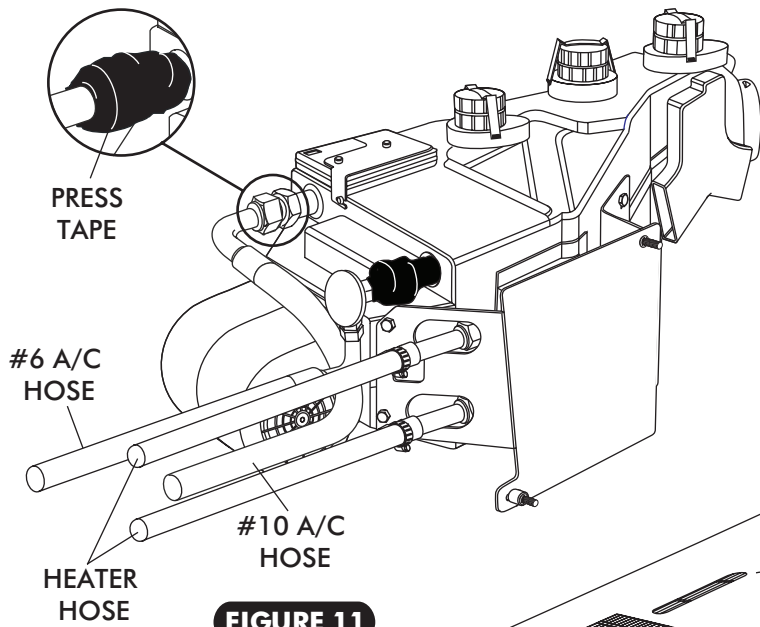

FIGURE 11

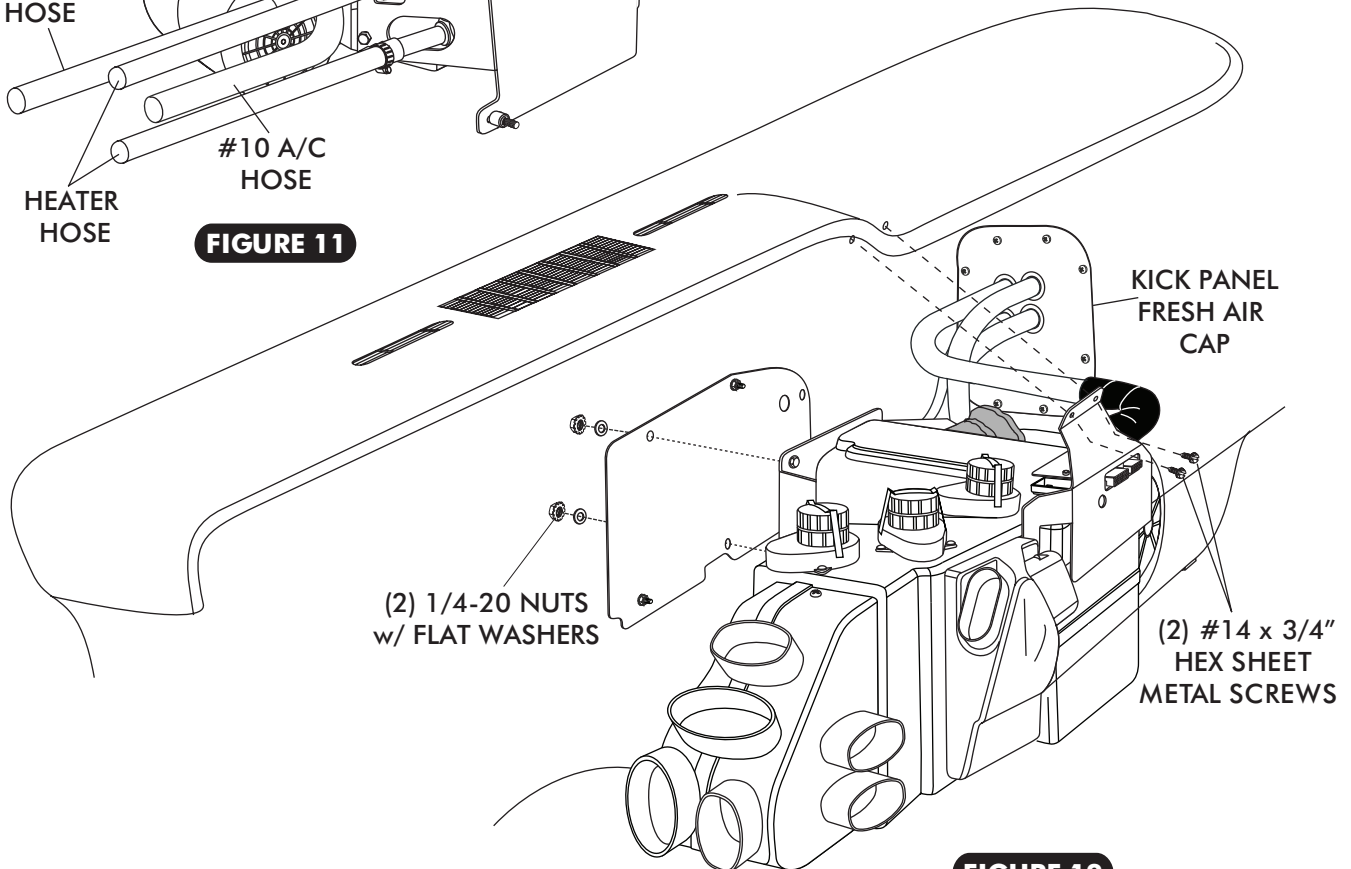

FIGURE 12



DRAIN HOSE INSTALLATION

- LOCATE EVAPORATOR DRAIN ON BOTTOM OF EVAPORATOR CASE.
- IN LINE WITH DRAIN, LIGHTLY MAKE A MARK ON THE FIREWALL. MEASURE 1" DOWN AND DRILL A 5/8" HOLE THROUGH THE FIREWALL. SEE FIGURE 13 BELOW.
- INSTALL DRAIN HOSE TO BOTTOM OF EVAPORATOR UNIT AND ROUTE THROUGH FIREWALL. INSTALL 1/2" 90° DRAIN ELBOW ON DRAIN HOSE. SEE FIGURE 13.

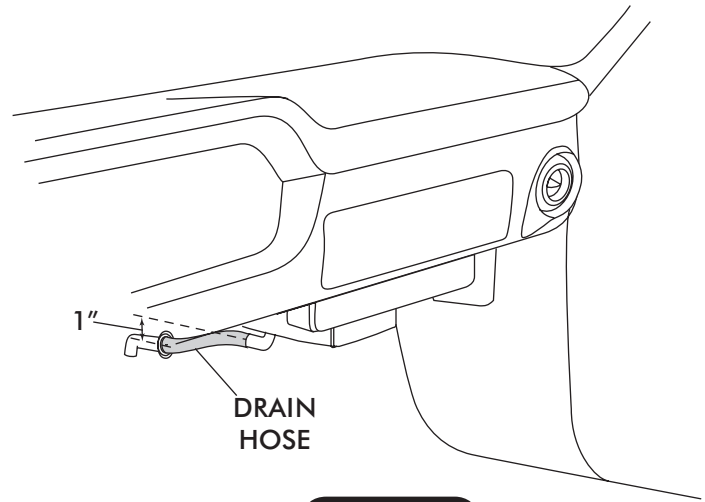
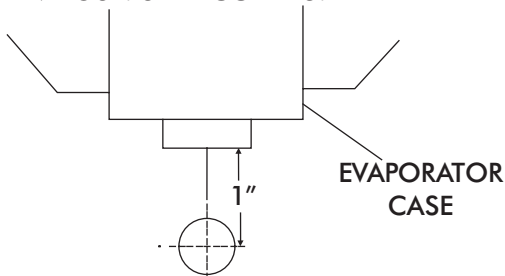

FIGURE 13

LUBRICATING O-RINGS

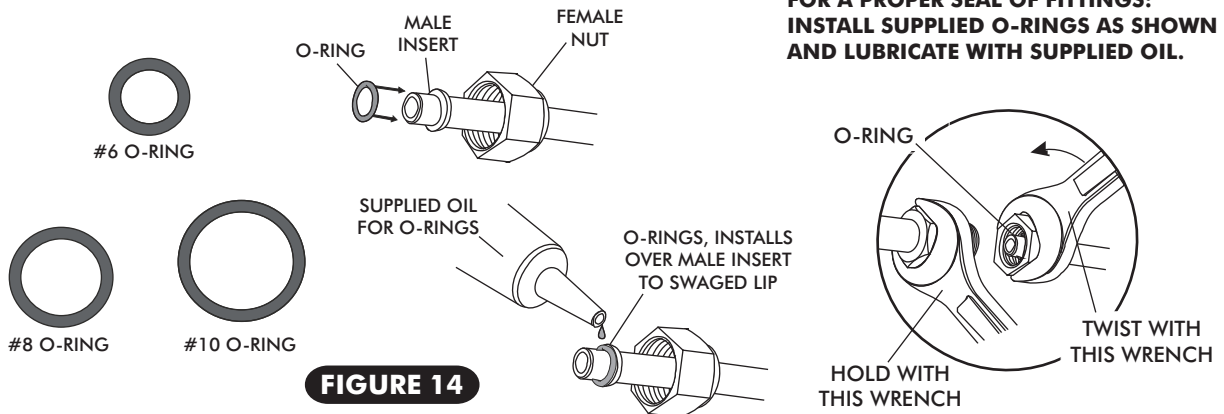

FIGURE 14

A/C HOSE INSTALLATION

STANDARD HOSE KIT

- LOCATE THE #8 COMPRESSOR A/C HOSE. LUBRICATE (2) #8 O-RINGS (SEE FIGURE 14, ABOVE) AND CONNECT THE 90° FEMALE FITTING TO THE #8 DISCHARGE PORT ON THE COMPRESSOR. ROUTE THE STRAIGHT FEMALE FITTING w/ 134a SERVICE PORT TO THE #8 CONDENSER HARDLINE COMING THROUGH CORE SUPPORT. SEE FIGURE 15 PAGE 14. TIGHTEN EACH FITTING CONNECTION AS SHOWN IN FIGURE 14 ABOVE.
- LOCATE THE #10 COMPRESSOR A/C HOSE. LUBRICATE (2) #10 O-RINGS (SEE FIGURE 14, ABOVE) AND CONNECT THE #10 135° FEMALE FITTING w/134a SERVICE PORT TO THE #10 SUCTION PORT ON THE COMPRESSOR. ROUTE THE 90° FEMALE FITTING TO THE #10 EVAPORATOR. SEE FIGURE 11 PAGE 12 AND FIGURE 15 PAGE 14. TIGHTEN EACH FITTING CONNECTION AS SHOWN IN 14 ABOVE.
- LOCATE THE #6 EVAPORATOR A/C HOSE. LUBRICATE (2) #6 O-RINGS (SEE FIGURE 14, ABOVE) AND CONNECT THE STRAIGHT FEMALE FITTING TO THE DRIER. ROUTE THE 90° FEMALE FITTING TO THE #6 EVAPORATOR. SEE FIGURE 11, PAGE 12 AND FIGURE 15 PAGE 14. TIGHTEN EACH FITTING CONNECTION AS SHOWN IN FIGURE 14, ABOVE.

MODIFIED A/C HOSE KIT

- REFER TO SEPARATE INSTRUCTIONS INCLUDED WITH MODIFIED HOSE KIT.



HEATER HOSE & HEATER CONTROL VALVE INSTALLATION

- ROUTE A PIECE OF HEATER HOSE FROM THE WATER PUMP TO THE TOP HEATER FITTING OF HEATER CORE AS SHOWN IN FIGURE 11, PAGE 12 AND FIGURE 15, BELOW. SECURE USING HOSE CLAMPS.
NOTE: OEM WATER PUMP OUTLET IS 3/4". A 3/4" x 5/8" REDUCER FITTING IS REQUIRED (NOT SUPPLIED).
- ROUTE A PIECE OF HEATER HOSE FROM THE INTAKE TO THE BOTTOM HEATER FITTING OF HEATER CORE AS SHOWN IN FIGURE 11, PAGE 12 AND FIGURE 15, BELOW. INSTALL HEATER CONTROL VALVE IN LINE WITH INTAKE MANIFOLD (PRESSURE SIDE) HEATER HOSE. SECURE USING HOSE CLAMPS AS SHOWN IN FIGURE 15, BELOW. **NOTE PROPER FLOW DIRECTION.**

A/C & HEATER HOSE ROUTING 64-67 GTO SHOWN

NOTE: OEM WATER PUMP OUTLET IS 3/4". A 3/4" x 5/8" REDUCER FITTING IS REQUIRED (NOT SUPPLIED)

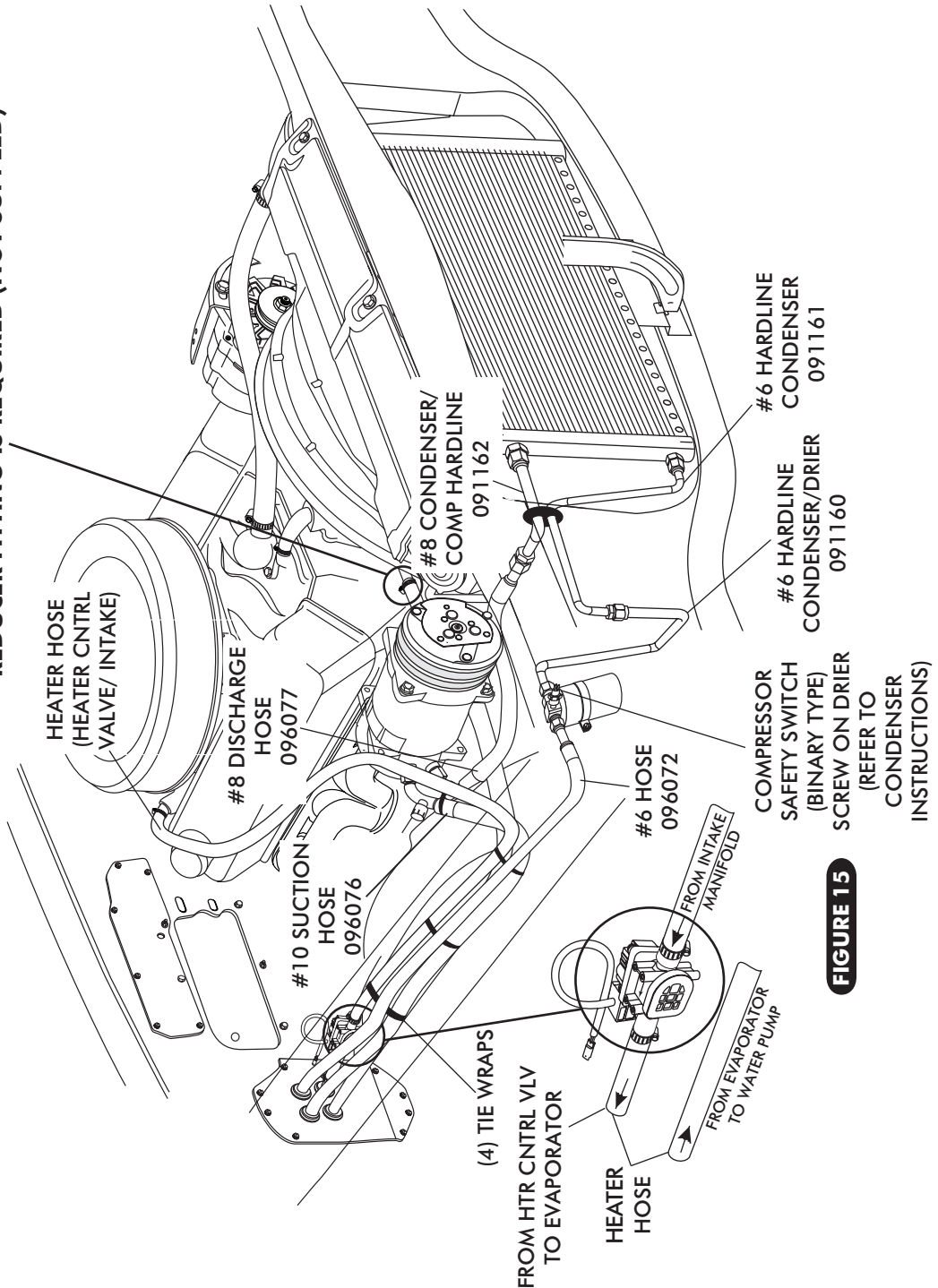

FIGURE 15



FINAL STEPS

- INSTALL DUCT HOSES AS SHOWN IN FIGURE 20, PAGE 17.
- ROUTE A/C WIRES THROUGH 3/8" GROMMET AS SHOWN IN FIGURE 16 (12 VOLT/ GROUND/ BINARY SWITCH/ HEATER VALVE).
- INSTALL CONTROL PANEL ASSEMBLY.
- PLUG THE WIRING HARNESS IN THE ECU MODULE ON SUB CASE AS SHOWN IN FIGURE 20, PAGE 17 (WIRE ACCORDING TO WIRING DIAGRAM ON PAGE 18 AND 19).
- INSTALL GLOVE BOX DOOR.
- INSTALL NEW GLOVE BOX USING OEM SCREWS, SEE FIGURE 17.
- MODIFY PASSENGER SIDE KICK PANEL AS SHOWN IN FIGURE 18 BELOW.
- REINSTALL ALL PREVIOUSLY REMOVED ITEMS, INNER FENDER.
- FILL RADIATOR WITH AT LEAST A 50/50 MIXTURE OF APPROVED ANTIFREEZE AND DISTILLED WATER. IT IS THE OWNER'S RESPONSIBILITY TO KEEP THE FREEZE PROTECTION AT THE PROPER LEVEL FOR THE CLIMATE IN WHICH THE VEHICLE IS OPERATED. FAILURE TO FOLLOW ANTIFREEZE RECOMMENDATIONS WILL CAUSE HEATER CORE TO CORRODE PREMATURELY AND POSSIBLY BURST IN A/C MODE AND/OR FREEZING WEATHER, VOIDING YOUR WARRANTY.
- DOUBLE CHECK ALL FITTINGS, BRACKETS AND BELTS FOR TIGHTNESS.
- VINTAGE AIR RECOMMENDS THAT ALL A/C SYSTEMS BE SERVICED BY A CERTIFIED AUTOMOTIVE AIR CONDITIONING TECHNICIAN.
- EVACUATE THE SYSTEM FOR A MINIMUM OF 45 MINUTES PRIOR TO CHARGING, AND LEAK CHECK PRIOR TO SERVICING.
- CHARGE THE SYSTEM TO THE CAPACITIES STATED ON THE INFORMATION PAGE (PAGE 4) OF THIS INSTRUCTION MANUAL.
- SEE OPERATION OF CONTROLS PROCEDURES PAGE 20 (64 GTO) AND PAGE 21 (65-67 GTO).

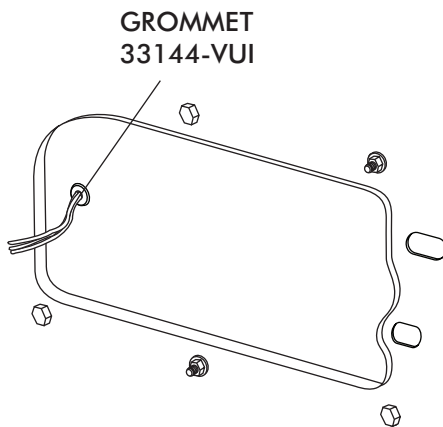

FIGURE 16

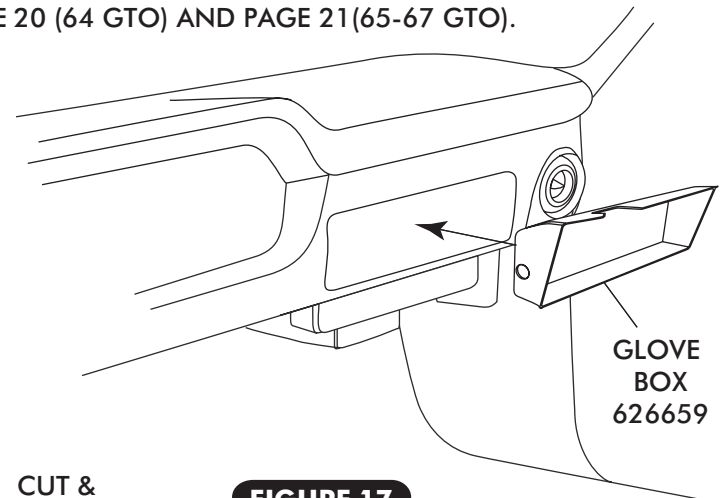

FIGURE 17

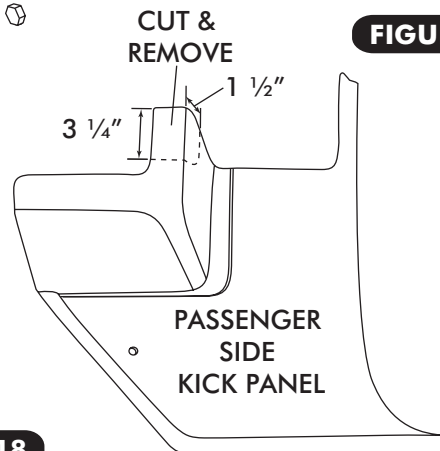
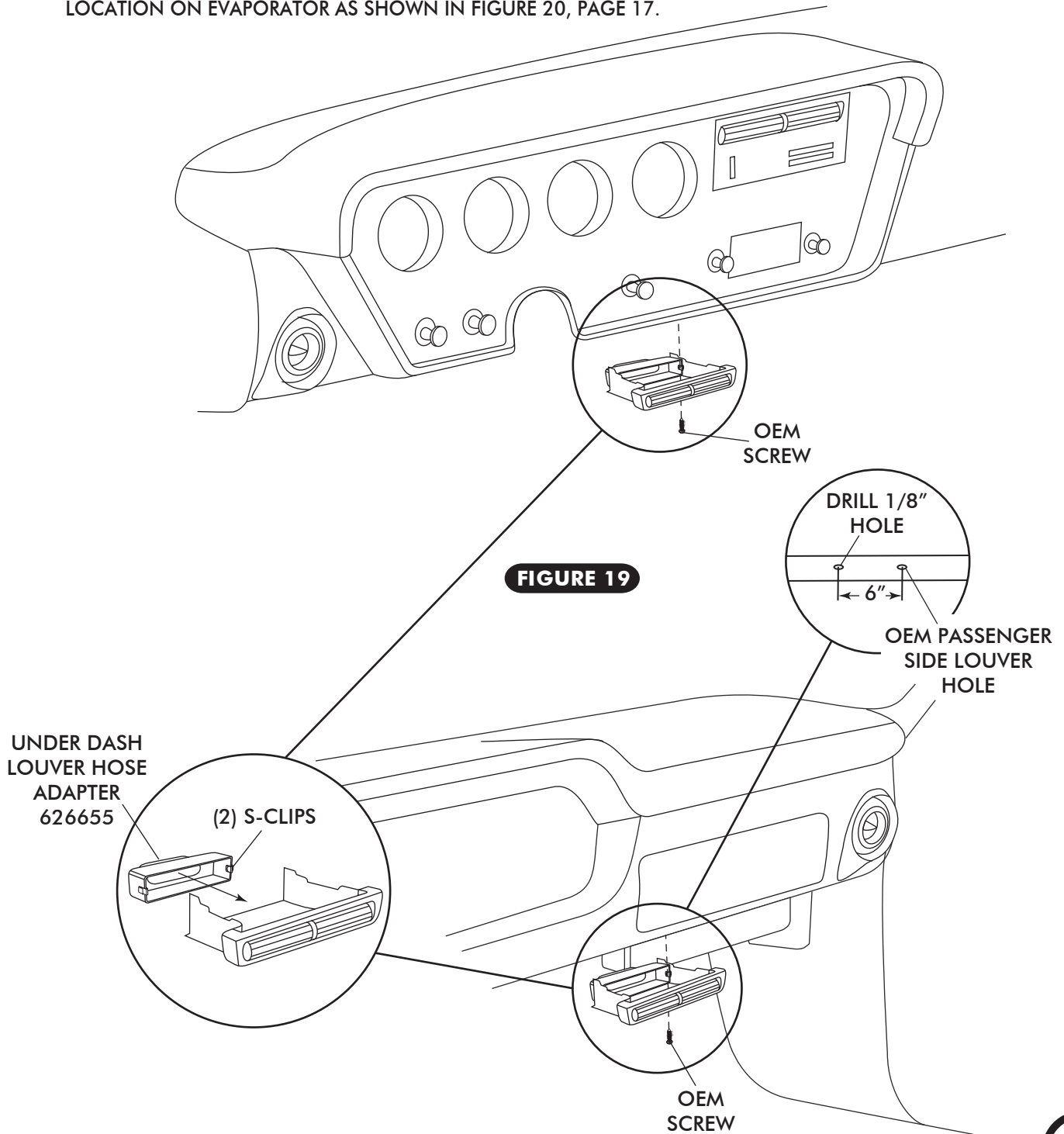

FIGURE 18



OEM UNDER DASH LOUVER HOSE ADAPTER INSTALLATION

- INSTALL HOSE ADAPTER AS SHOWN IN FIGURE 19 BELOW.
- PASSENGER SIDE UNDER DASH LOUVER MUST BE RELOCATED AS SHOWN BELOW.
- DRILL 1/8" HOLE AND INSTALL LOUVER USING OEM SCREWS.
- ONCE THE LOUVER ASSEMBLY IS IN PLACE, ROUTE THE DUCT HOSES AND ATTACH THEM TO THE CORRECT LOCATION ON EVAPORATOR AS SHOWN IN FIGURE 20, PAGE 17.





CONTROL PANEL & DUCT HOSE ROUTING

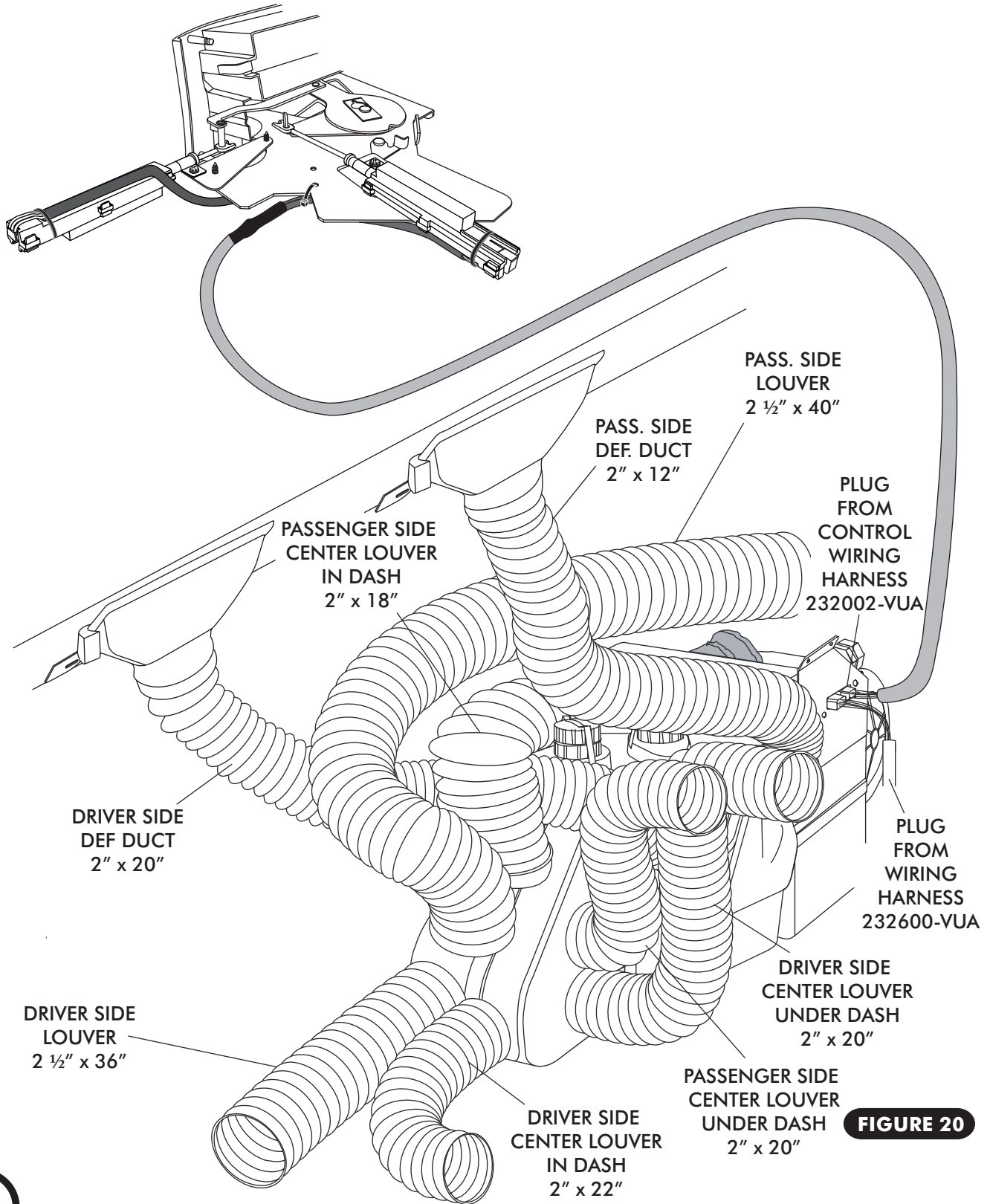

FIGURE 20



Wiring Diagram

REVISION C 10/06/17

232007-VUR

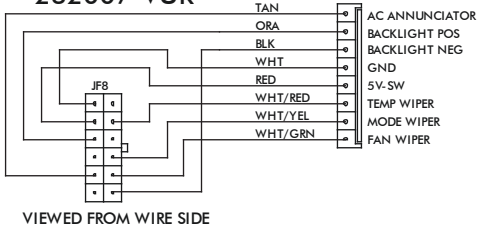

232002-VUA

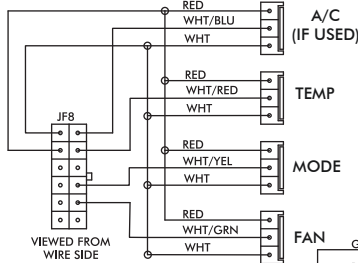

GEN IV ECU

GEN IV WIRING DIAGRAM
REV D, 5/6/2014

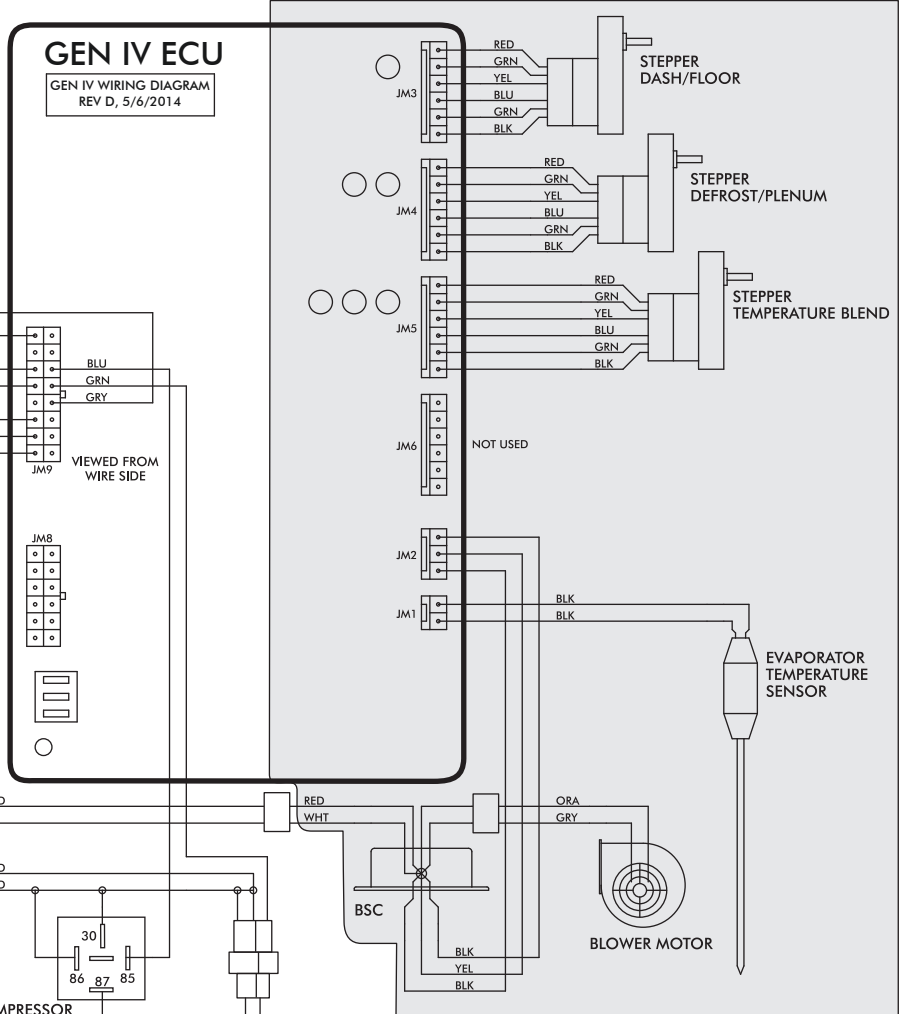

PROGRAM

N/A

* DASH LAMP (IF USED)

*** WIDE OPEN THROTTLE SWITCH (OPTIONAL)

WHT

IGNITION SWITCH

+ 12v

BATTERY

** CIRCUIT BREAKER 30 AMP

COMPR

HEATER CONTROL VALVE

NOTE: = CHASSIS GROUND

• Dash Lamp Is Used Only With Type 232007-VUR Harness.

•• Warning: Always Mount Circuit Breaker As Close to the Battery As Possible. (NOTE: Wire Between Battery and Circuit Breaker Is Unprotected and Should Be Carefully Routed to Avoid a Short Circuit).

••• Wide Open Throttle Switch Contacts Close Only at Full Throttle, Which Disables A/C Compressor.



Gen IV Wiring Connection Instruction

WIRING HARNESS

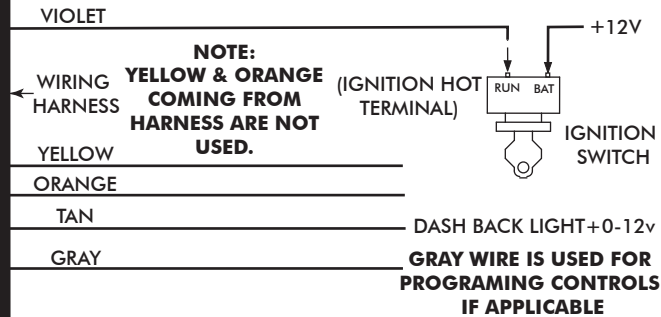
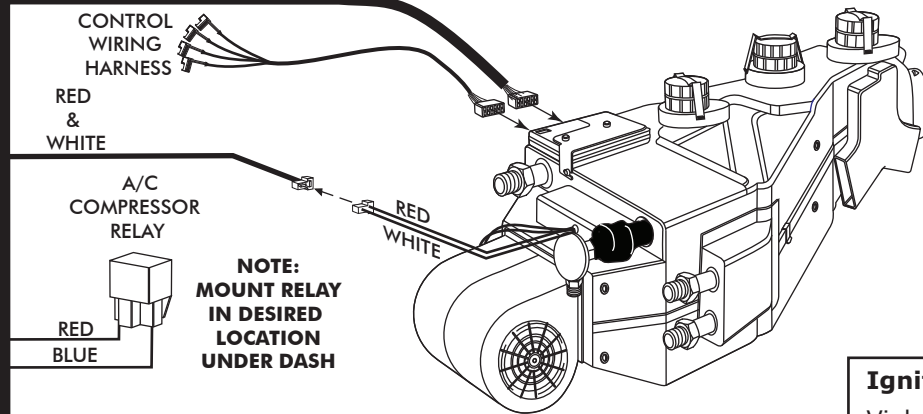

Ignition Switch:
Violet 12V Ign Switch Source (Key On Accessory) Position Must Be Switched.

Dash Light:
Tan Wire Used Only With Vintage Air Supplied Control Panel With LED Back Light.

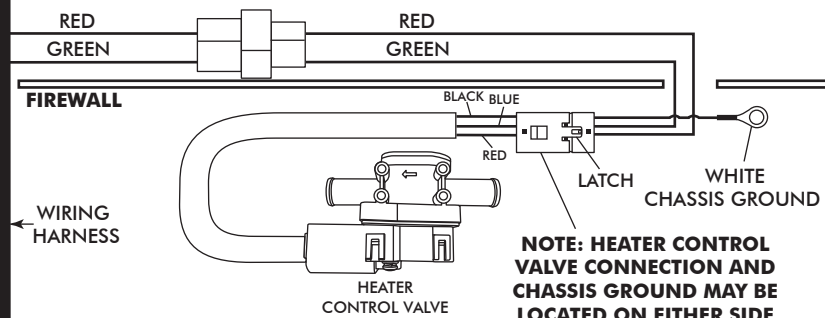

Heater Control Valve:
Install With Servo Motor Facing Down, As Shown. Note Flow Direction Arrow Molded Into Valve Body, And Install Accordingly.

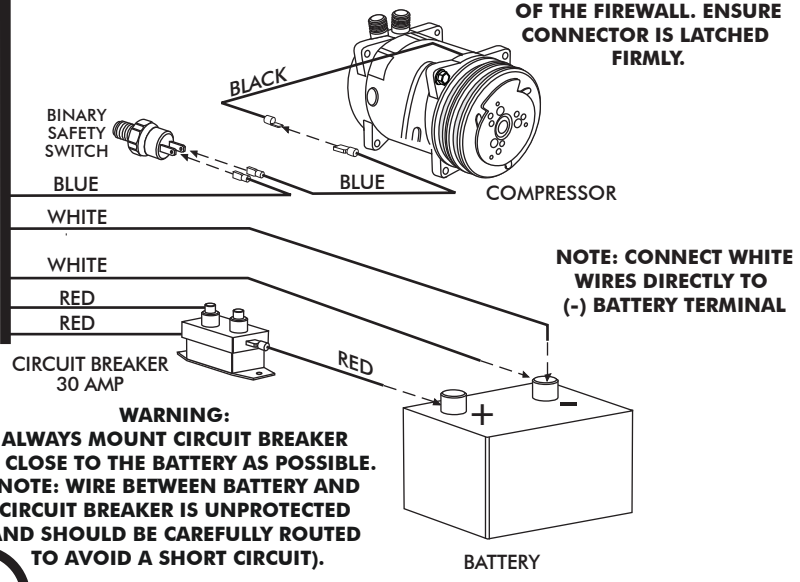

Binary/Trinary & Compressor:
Binary: Connect As Shown (Typical Compressor Wiring). Be Sure Compressor Body Is Grounded.
Trinary Switch: Connect According To Trinary Switch Wiring Diagram.

Circuit Breaker/Battery:
White **Must** Run To (-) Battery. Red May Run To (+) Battery Or Starter. Mount Circuit Breaker As Close to Battery As Possible.



OPERATION OF CONTROLS (64 GTO ONLY)

NOTE: CONTROLS MUST BE CALIBRATED FOR PROPER OPERATION.

THE TEMPERATURE LEVER TOGGLES BETWEEN A/C AND HEAT MODES. FOR A/C MODE SLIDE THE TEMPERATURE LEVER ALL THE WAY LEFT TO ENGAGE THE COMPRESSOR, THEN MOVE THE LEVER TO SELECT THE DESIRED TEMPERATURE. FOR HEAT MODE SLIDE THE LEVER RIGHT TO DISENGAGE THE COMPRESSOR, THEN MOVE THE LEVER TO SELECT DESIRED TEMPRATURE.

NOTE: EACH TIME THE SYSTEM TOGGLES BETWEEN MODES, THE BLOWER WILL MOMENTARILY CHANGE SPEEDS.

ALL SWITCHES ARE VARIABLE BETWEEN POSITIONS, SYSTEM WILL PERFORM A BLEND BETWEEN THE FUNCTIONS.

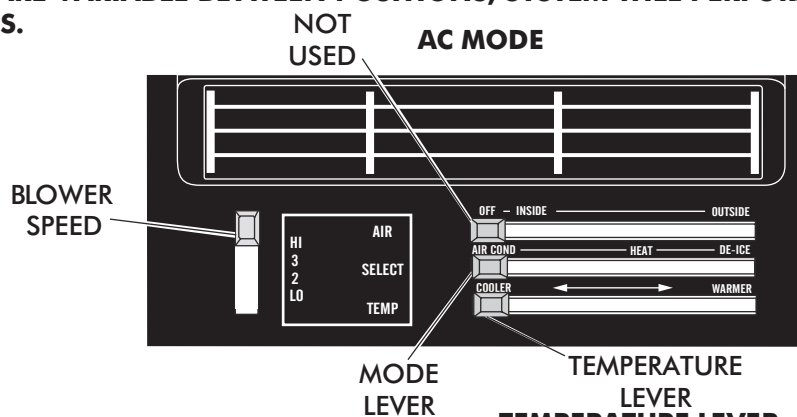

BLOWER SPEED
ADJUST TO DESIRED SPEED

MODE LEVER
SLIDE THE LEVER TO THE LEFT POSITION

TEMPERATURE LEVER
IN A/C MODE SLIDE THE TEMPERATURE LEVER ALL THE WAY TO THE LEFT TO ENGAGE COMPRESSOR. (SLIDE LEVER LEFT OR RIGHT TO ADJUST DESIRED TEMPERATURE)

HEAT MODE

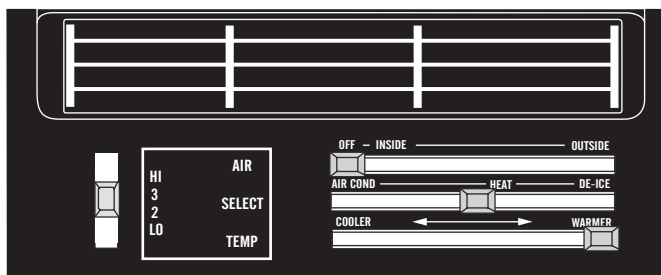

BLOWER SPEED
ADJUST TO DESIRED SPEED

MODE LEVER
SLIDE THE LEVER TO THE CENTER POSITION

TEMPERATURE LEVER
SLIDE THE TEMPERATURE LEVER ALL THE WAY RIGHT TO THE WARMER POSITION. (SLIDE LEVER LEFT OR RIGHT TO DESIRED TEMPERATURE)

DEFROST/ DE-FOG MODE

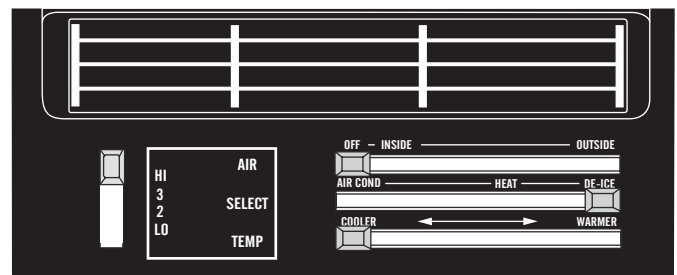

BLOWER SPEED
ADJUST TO DESIRED SPEED

MODE LEVER
SLIDE THE LEVER TO THE RIGHT POSITION

TEMPERATURE LEVER
ADJUST LEVER TO DESIRED TEMPERATURE. (COMPRESSOR IS AUTOMATICALLY ENGAGED)



OPERATION OF CONTROLS (65-67 GTO ONLY)

NOTE: CONTROLS MUST BE CALIBRATED FOR PROPER OPERATION.

THE TEMPERATURE LEVER TOGGLES BETWEEN A/C AND HEAT MODES. FOR A/C MODE SLIDE THE TEMPERATURE LEVER ALL THE WAY LEFT TO ENGAGE THE COMPRESSOR, THEN MOVE THE LEVER TO SELECT THE DESIRED TEMPERATURE. FOR HEAT MODE SLIDE THE LEVER RIGHT TO DISENGAGE THE COMPRESSOR, THEN MOVE THE LEVER TO SELECT DESIRED TEMPRATURE.

NOTE: EACH TIME THE SYSTEM TOGGLES BETWEEN MODES, THE BLOWER WILL MOMENTARILY CHANGE SPEEDS.

ALL SWITCHES ARE VARIABLE BETWEEN POSITIONS, SYSTEM WILL PERFORM A BLEND BETWEEN THE FUNCTIONS.

AC MODE

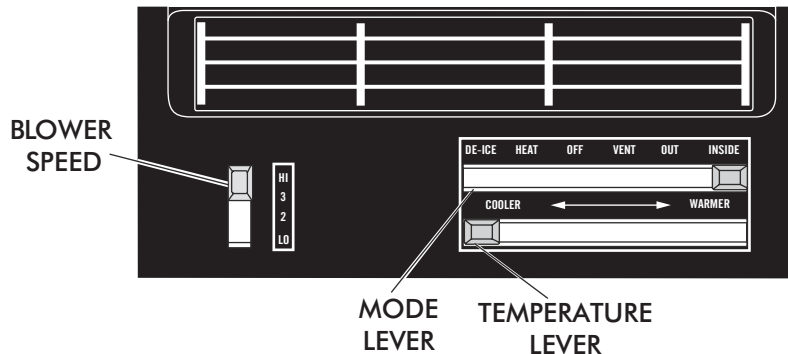

BLOWER SPEED
ADJUST TO DESIRED SPEED

MODE LEVER
SLIDE THE LEVER TO THE RIGHT POSITION

TEMPERATURE LEVER
IN A/C MODE SLIDE THE TEMPERATURE LEVER ALL THE WAY TO THE LEFT TO ENGAGE COMPRESSOR. (SLIDE LEVER LEFT OR RIGHT TO ADJUST DESIRED TEMPERATURE)

HEAT MODE

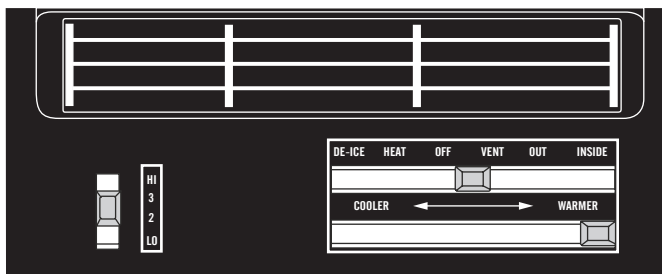

BLOWER SPEED
ADJUST TO DESIRED SPEED

MODE LEVER
SLIDE THE LEVER TO THE CENTER POSITION

TEMPERATURE LEVER
SLIDE THE TEMPERATURE LEVER ALL THE WAY RIGHT TO THE WARMER POSITION. (SLIDE LEVER LEFT OR RIGHT TO DESIRED TEMPERATURE)

DEFROST/ DE-FOG MODE

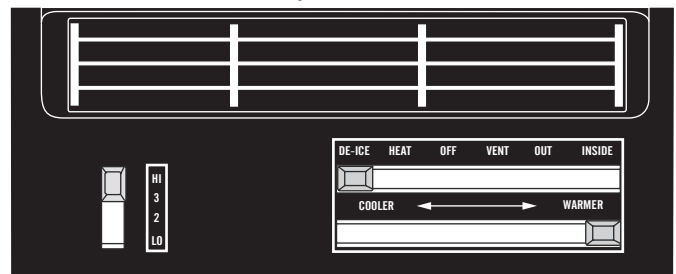

BLOWER SPEED
ADJUST TO DESIRED SPEED

MODE LEVER
SLIDE THE LEVER TO THE LEFT POSITION

TEMPERATURE LEVER
ADJUST LEVER TO DESIRED TEMPERATURE. (COMPRESSOR IS AUTOMATICALLY ENGAGED)



Troubleshooting Guide

Symptom	Condition	Checks	Actions	Notes	
1a.	Blower stays on high speed when ignition is on.	No other functions work.	Verify that all pins are inserted into plug. Ensure that no pins are bent or damaged in ECU.	Loss of ground on this wire renders control head inoperable. See blower switch check procedure.	
		All other functions work.	Check for damaged pins or wires in control head plug. Check for damaged ground wire (white) in control head harness. Check for damaged blower switch or potentiometer and associated wiring.		Verify continuity to chassis ground with white control head wire at various points.
1b.	Blower stays on high speed when ignition is on or off.		Be sure the small, 20 GA white ground wire is connected to the battery ground post. If it is, replace the ECU.	No other part replacements should be necessary.	
			Unplug 3-wire BSC control connector from ECU. If blower shuts off, ECU is either improperly wired or damaged.		Check to ensure that no BSC wiring is damaged or shorted to vehicle ground. The BSC operates the blower by ground side pulse width modulation switching. The positive wire to the blower will always be hot. If the "ground" side of the blower is shorted to chassis ground, the blower will run on HI.
			Unplug 3-wire BSC control connector from ECU. If blower stays running, BSC is either improperly wired or damaged.		Replace BSC (This will require removal of evaporator from vehicle).
2.	Compressor will not turn on (All other functions work).	System is not charged.	Charge system or bypass pressure switch.	Danger: Never bypass safety switch with engine running. Serious injury can result. To check for proper pot function, check voltage at white/blue wire. Voltage should be between 0V and 5V, and will vary with pot lever position. Disconnected or faulty thermistor will cause compressor to be disabled.	
		System is charged.	Check for faulty A/C potentiometer or associated wiring (Not applicable to 3-pot controls).		To check for proper pot function, check voltage at white/blue wire. Voltage should be between 0V and 5V, and will vary with pot lever position.
		System is charged.	Check for disconnected or faulty thermistor.		Disconnected or faulty thermistor will cause compressor to be disabled.
3.	Compressor will not turn off (All other functions work).		Repair or replace pot/control wiring.	Red wire at A/C pot should have approximately 5V with ignition on. White wire will have continuity to chassis ground. White/Blue wire should vary between 0V and 5V when lever is moved up or down.	
			Check for faulty A/C potentiometer or associated wiring.		
			Check for faulty A/C relay.		Replace relay.



Troubleshooting Guide (Cont.)

Symptom	Condition	Checks	Actions	Notes
4. System will not turn on, or runs intermittently.	Works when engine is not running; shuts off when engine is started (Typically early Gen IV, but possible on all versions).	Noise interference from either ignition or alternator.	Install capacitors on ignition coil and alternator. Ensure good ground at all points. Relocate coil and associated wiring away from ECU and ECU wiring. Check for burned or loose plug wires.	Ignition noise (radiated or conducted) will cause the system to shut down due to high voltage spikes. If this is suspected, check with a quality oscilloscope. Spikes greater than 16V will shut down the ECU. Install a radio capacitor at the positive post of the ignition coil (See radio capacitor installation bulletin). A faulty alternator or worn out battery can also result in this condition.
	Will not turn on under any conditions.	Verify connections on power lead, ignition lead, and both white ground wires.	Check for positive power at heater valve green wire and blower red wire. Check for ground on control head white wire.	
		Verify battery voltage is greater than 10 volts and less than 16.	Verify proper meter function by checking the condition of a known good battery.	
		Check for damaged mode switch or potentiometer and associated wiring.		
5. Loss of mode door function.	No mode change at all.	Check for obstructed or binding mode doors.		Typically caused by evaporator housing installed in a bind in the vehicle. Be sure all mounting locations line up and don't have to be forced into position.
	Partial function of mode doors.	Check for damaged stepper motor or wiring.		
		Check for at least 12V at circuit breaker.	Ensure all system grounds and power connections are clean and tight.	
6. Blower turns on and off rapidly.	Battery voltage is at least 12V.	Check for faulty battery or alternator.	Charge battery.	System shuts off blower at 10V. Poor connections or weak battery can cause shutdown at up to 11V.
	Battery voltage is less than 12V.			
7. Erratic functions of blower, mode, temp, etc.		Check for damaged switch or pot and associated wiring.	Repair or replace.	
		This is an indicator that the system has been reset. Be sure the red power wire is on the battery post, and not on a switched source. Also, if the system is pulled below 7V for even a split second, the system will reset.	Run red power wire directly to battery.	



EVAPORATOR KIT PACKING LIST

EVAPORATOR KIT
564467

NO.	QTY.	PART NO.	DESCRIPTION
1.	1	744002	GEN IV 6-VENT EVAPORATOR SUB CASE with 204 ECU
2.	1	784158	1964-67 GTO with A/C ACCESSORY KIT

CHECK BY: _____
 PACKED BY: _____
 DATE: _____

①

**GEN IV 6-VENT
EVAPORATOR SUB CASE
with 204 ECU
744002**

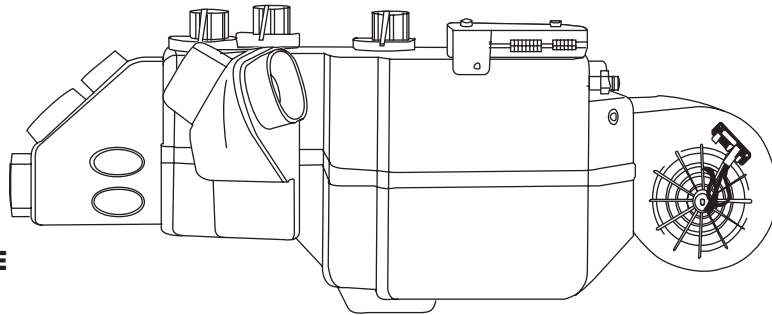

②

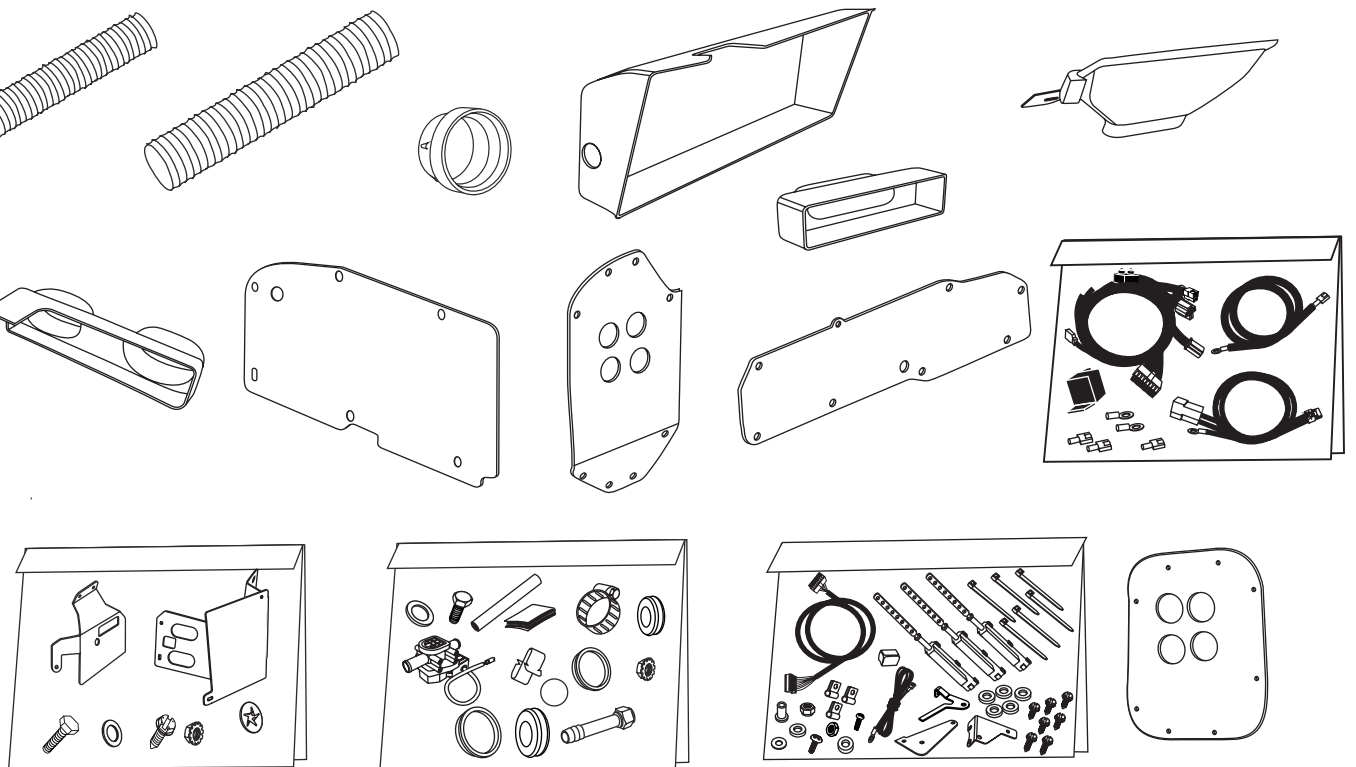

**ACCESSORY KIT
784158**

**NOTE: IMAGES MAY NOT DEPICT ACTUAL PARTS AND QUANTITIES.
REFER TO PACKING LIST FOR ACTUAL PARTS AND QUANTITIES.**