

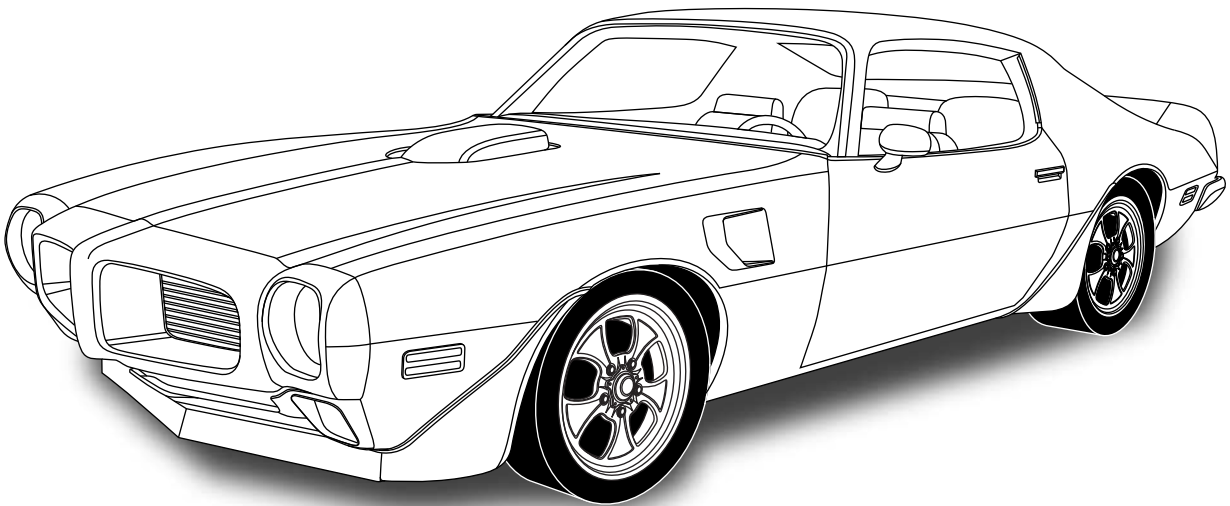

an ISO 9001:2008 Registered Company

1970-81 Pontiac Firebird

with **Factory Air
Evaporator Kit
(564150)**



18865 Goll St. San Antonio, TX 78266
Phone: 210-654-7171
Fax: 210-654-3113
www.vintageair.com



www.vintageair.com

Table of Contents

Thank you for purchasing this evaporator kit from Vintage Air. When installing these components as part of a complete SureFit™ system, Vintage Air recommends working from front to back on the vehicle, installing the condenser kit, hose kit, and compressor first, followed by the wiring, evaporator, and finally the control panel.

- Cover..... 1
- Table of Contents..... 2
- Packing List/Parts Disclaimer..... 3
- Information Page.....4
- Wiring Notice..... 5
- Engine Compartment Disassembly, Condenser Assembly and Installation, Compressor and Brackets..... 6
- Engine Compartment Disassembly (Cont.)..... 7
- OEM Control Panel Removal..... 8
- OEM Control Panel Removal (Cont.)..... 9
- Passenger Compartment Disassembly.....10
- Fresh Air Cap Installation, Heater Cover Assembly and Firewall Cover Installation..... 11
- Heater Cover Assembly and Firewall Cover Installation (Cont.), Defrost Duct Installation..... 12
- Hose Adapter Installation..... 13
- Passenger Side Kick Panel and Fresh Air Cover Modification.....14
- Kick Panel Fresh Air Cap Installation, Evaporator Installation..... 15
- Evaporator Installation (Cont.)..... 16
- Evaporator Installation (Final)..... 17
- Drain Hose Installation, Lubricating O-rings, A/C Hose Installation..... 18
- Heater Hose & Heater Control Valve Installation, A/C and Heater Hose Routing.....19
- Final Steps, Under Dash Hose Adapter Assembly Installation..... 20
- Glove Box Installation, Driver Side Under Dash Cover Installation..... 21
- Control Panel & Duct Hose Routing.....22
- Wiring Diagram..... 23
- Gen IV Wiring Connection Instruction..... 24
- Operation of Controls..... 25
- Troubleshooting Guide.....26
- Troubleshooting Guide (Cont.)..... 27
- Packing List..... 28



www.vintageair.com

Packing List: Evaporator Kit (564150)

No.	Qty.	Part No.	Description
1.	1	762171	Gen IV 6-Vent Evaporator Sub Case with 204 ECU
2.	1	781181	Accessory Kit

**** Before beginning installation, open all packages and check contents of shipment. Please report any shortages directly to Vintage Air within 15 days. After 15 days, Vintage Air will not be responsible for missing or damaged items.**

1

**Gen IV 6-Vent Evaporator
Sub Case
w/ 204 ECU
762171**

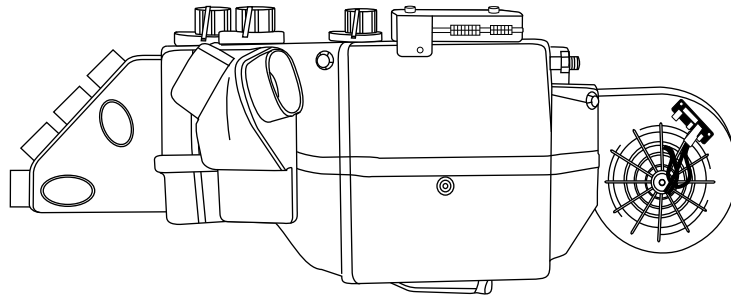

2

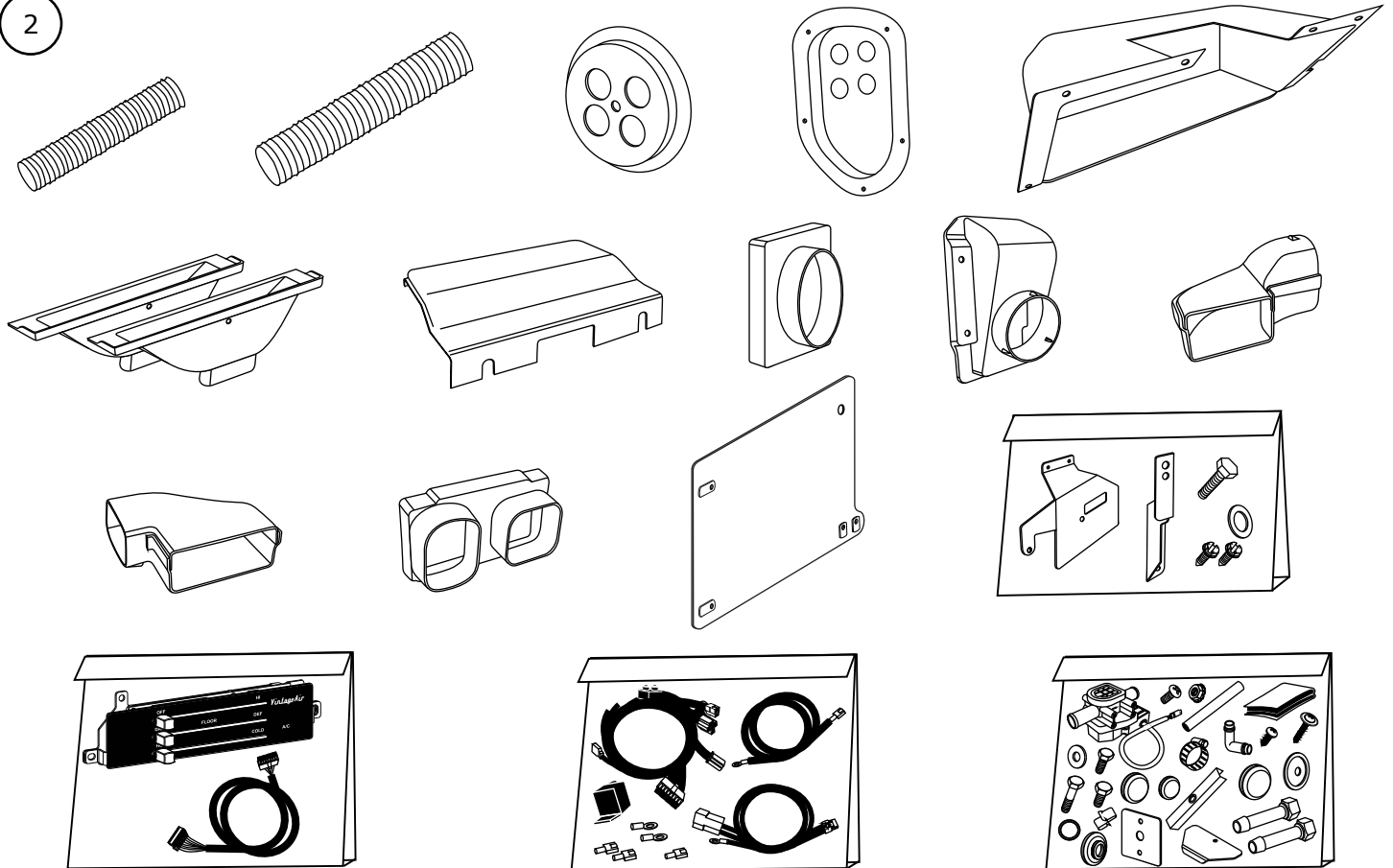

**Accessory Kit
781181**

NOTE: Images may not depict actual parts and quantities. Refer to packing list for actual parts and quantities.



www.vintageair.com

Important Notice—Please Read

For Maximum System Performance, Vintage Air Recommends the Following:

NOTE: Vintage Air systems are designed to operate with R134a refrigerant only. Use of any other refrigerant could damage your A/C system and/or vehicle, and possibly cause a fire, in addition to potentially voiding the warranties of the A/C system and its components.

Refrigerant Capacities:

Vintage Air System: 1.8 lbs. (1 lb., 12 oz.) of **R134a**, charged by weight with a quality charging station or scale. **NOTE:** Use of the proper type and amount of refrigerant is critical to system operation and performance.

Other Systems: Consult manufacturer's guidelines.

Lubricant Capacities:

New Vintage Air-supplied Sanden Compressor: No additional oil needed (Compressor is shipped with proper oil charge).

All Other Compressors: Consult manufacturer (Some compressors are shipped dry and will need oil added).

Safety Switches

Your Vintage Air system is equipped with a binary pressure safety switch. A binary switch disengages the compressor clutch in cases of extreme low pressure conditions (Refrigerant Loss) or excessively high head pressure (406 PSI) to prevent compressor damage or hose rupture. A trinary switch combines Hi/Lo pressure protection with an electric fan operation signal at 254 PSI, and should be substituted for use with electric fans. Compressor safety switches are extremely important since an A/C system relies on refrigerant to circulate lubricant.

Service Info:

Protect Your Investment: Prior to assembly, it is critical that the compressor, evaporator, A/C hoses and fittings, hardlines, condenser and receiver/drier remained capped. Removing caps prior to assembly will allow moisture, insects and debris into the components, possibly leading to reduced performance and/or premature failure of your A/C system. This is especially important with the receiver/drier.

Additionally, when caps are removed for assembly, **BE CAREFUL!** Some components are shipped under pressure with dry nitrogen.

Evacuate the System for 35-45 Minutes: Ensure that system components (Drier, compressor, evaporator and condenser) are at a temperature of at least 85° F. On a cool day, the components can be heated with a heat gun **or** by running the engine with the heater on before evacuating. Leak check and charge to specifications.

Bolts Passing Through Cowl and/or Firewall:

To ensure a watertight seal between the passenger compartment and the vehicle exterior, for all bolts passing through the cowl and/or firewall, Vintage Air recommends coating the threads with silicone prior to installation.

Heater Hose (Not Included With This Kit):

Heater hose may be purchased from Vintage Air (Part# 31800-VUD) or your local parts retailer. Routing and required length will vary based on installer preference.



www.vintageair.com

Important Wiring Notice—Please Read

Some Vehicles May Have Had Some or All of Their Radio Interference Capacitors Removed. There Should Be a Capacitor Found At Each of the Following Locations:

- 1. On the positive terminal of the ignition coil.**
- 2. If there is a generator, on the armature terminal of the generator.**
- 3. If there is a generator, on the battery terminal of the voltage regulator.**

Most alternators have a capacitor installed internally to eliminate what is called “whining” as the engine is revved. If whining is heard in the radio, or just to be extra cautious, a radio interference capacitor can be added to the battery terminal of the alternator.

It is also important that the battery lead is in good shape and that the ground leads are not compromised. There should be a heavy ground from the battery to the engine block, and additional grounds to the body and chassis.

If these precautions are not observed, it is possible for voltage spikes to be present on the battery leads. These spikes come from ignition systems, charging systems, and from switching some of the vehicle’s other systems on and off. Modern computer-operated equipment can be sensitive to voltage spikes on the power leads, which can cause unexpected resets, strange behavior, and/or permanent damage.

Vintage Air strives to harden our products against these types of electrical noise, but there is a point where a vehicle’s electrical system can be degraded so much that nothing can help.

Radio interference capacitors should be available at most auto and truck parts suppliers. They typically are cylindrical in shape, a little over an inch long, a little over a half inch in diameter, and they have a single lead coming from one end of the cylinder with a terminal on the end of the wire, as well as a mounting clip which is screwed into a good ground on the vehicle. The specific value of the capacitance is not too significant in comparison to ignition capacitors that are matched with the coil to reduce pitting of the points.

- Care must be taken, when installing the compressor lead, not to short it to ground. The compressor lead must not be connected to a condenser fan or to any other auxiliary device. Shorting to ground or connecting to a condenser fan or any other auxiliary device may damage wiring, the compressor relay, and/or cause a malfunction.
- When installing ground leads on Gen IV systems, the blower control ground and ECU ground must be connected directly to the negative battery post.
- For proper system operation, the heater control valve must be connected to the ECU.



www.vintageair.com

Engine Compartment Disassembly

NOTE: Before starting the installation, check the function of the vehicle (horn, lights, etc.) for proper operation, and study the instructions, illustrations, & diagrams.

Perform the Following (NOTE: Retain OEM bolts, screws, washers and nuts, as some hardware will be reused):

1. Remove the hood and the passenger side hood hinge. Make a mark around the hood hinge to show where it is located.
2. Place (2) jack stands under the sway bar below the frame to keep the complete frame straight (See Photo 1, below).
3. Disconnect battery.
4. Drain radiator.
5. Evacuate the A/C system, and loosen the expansion valve nut to drain the refrigerant oil (See Photos 2 & 3, Page 7). **NOTE: Refrigerant oil may be under pressure. Be careful when loosening the expansion valve nut, and place a rag around the fitting to absorb the oil.**
6. Remove the expansion valve nut (discard) (See Photo 3, Page 7).
7. Remove the A/C and heater hoses, lines and A/C muffler (discard) (See Photo 4, Page 7).
8. Remove the air cleaner (retain) (See Photo 4, Page 7).
9. Remove the OEM compressor and brackets (discard) (See Photo 4, Page 7).
10. Remove the passenger side front tire (retain).
11. Remove the passenger side inner fender and radiator overflow (retain) (See Photo 6, Page 7). To remove the inner fender, remove the passenger side lower fender bolts (See Photo 5, Page 7). **NOTE: Protect the fender and door to avoid scratching the paint.**
12. Remove the OEM A/C and heater wiring (discard) (See Photo 7, Page 7).
13. Remove the OEM evaporator with blower motor (discard) (See Photo 7, Page 7).

Condenser Assembly and Installation

1. Refer to separate instructions included with the condenser kit to install the condenser.
2. Binary switch installation (Refer to condenser instructions).

Compressor and Brackets

1. Refer to separate instructions included with the bracket kit to install the compressor bracket.

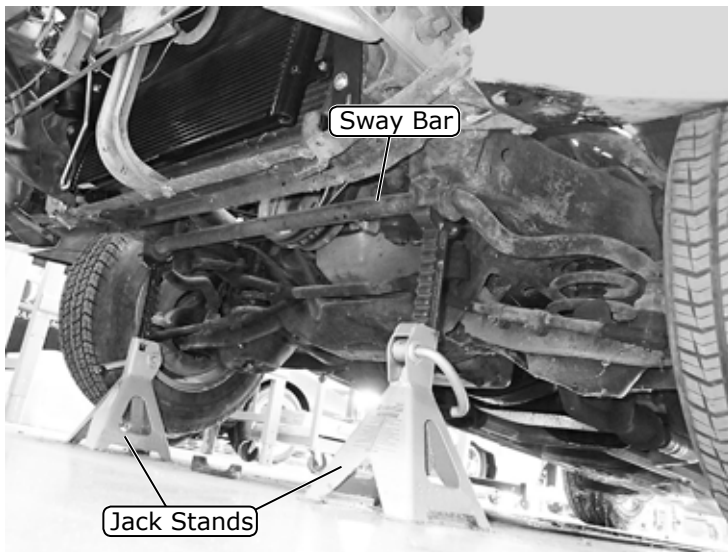

Photo 1

Engine Compartment Disassembly (Cont.)

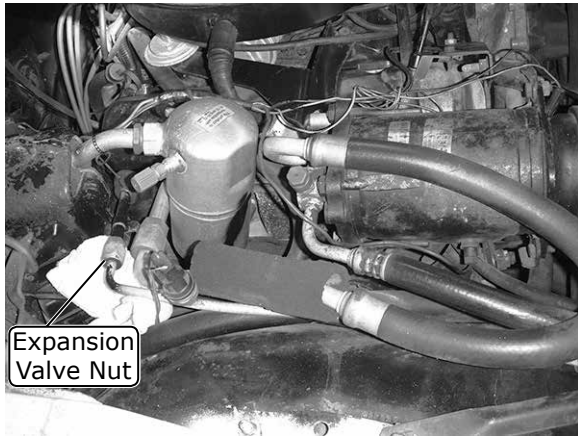

Photo 2

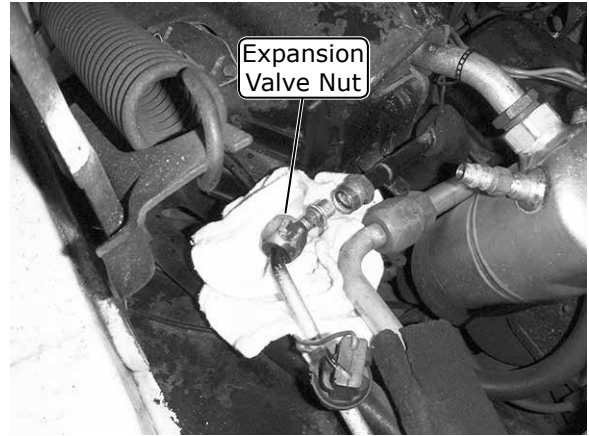

Photo 3

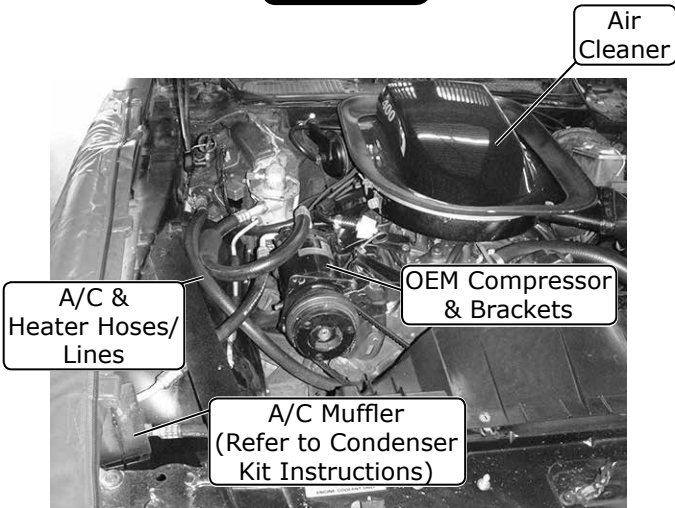

Photo 4

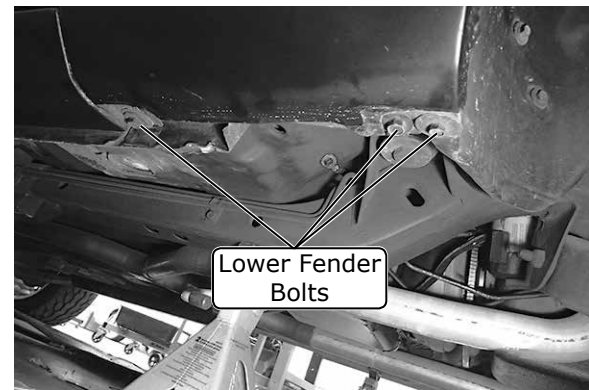

Photo 5



Photo 6

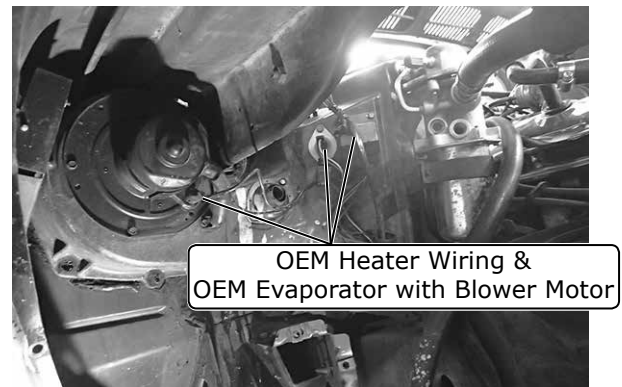

Photo 7



www.vintageair.com

OEM Control Panel Removal

Perform the Following:

1. Remove (2) screws retaining the plastic cover beneath the steering column as shown in Photo 8, below (retain). Remove the cover (retain).
2. Remove the instrument panel trim plate by removing (2) lower screws (See Photo 9, below), (3) upper screws (See Photo 10, below), and the lighter retainer nut ring (See Photos 11 and 11a, Page 9) (retain).
3. Disconnect cables and wires from the back of the control panel as shown in Photo 13, Page 9. **NOTE: For ease of access to the control panel cables and wires, Vintage Air recommends removing the gauge cluster located directly above the control panel (See Photo 12, Page 9).**
4. Remove the OEM control panel (discard).

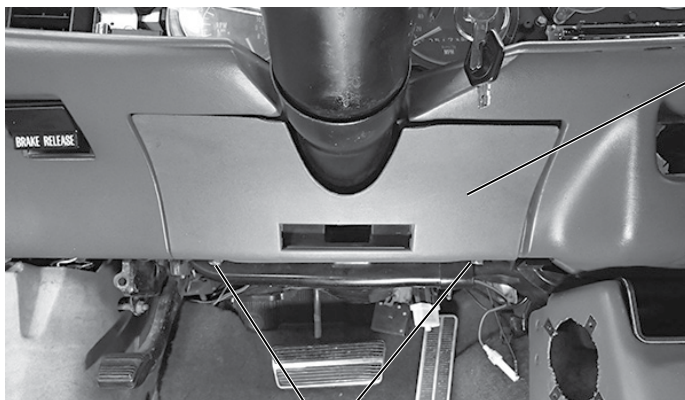

Plastic
Cover

Photo 8

Remove
(2) Screws

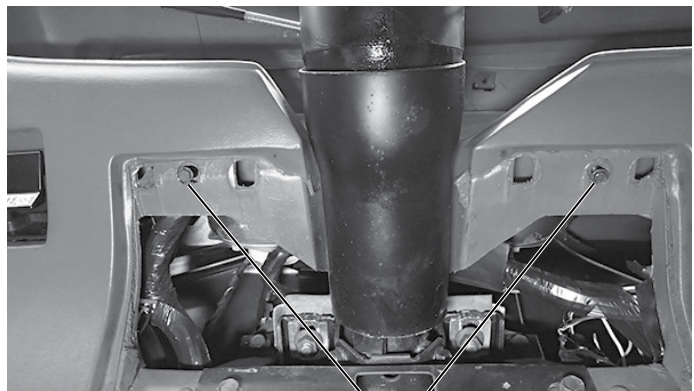

Photo 9

Remove
(2) Screws



Instrument
Panel Trim Plate

Remove
(3) Screws

Photo 10

OEM Control Panel Removal (Cont.)

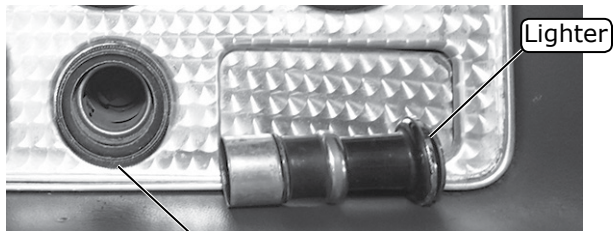

Photo 11

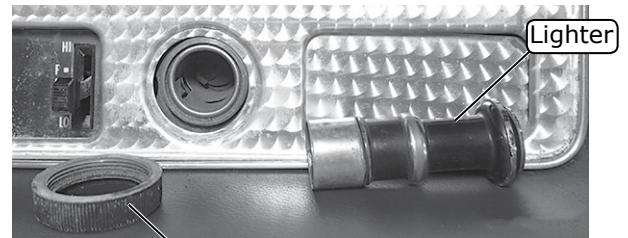

Photo 11a

Remove OEM Screw
Lighter Retainer Nut Ring

Gauge Cluster
Lighter Retainer Nut Ring

Remove OEM Screw

Remove OEM Screw

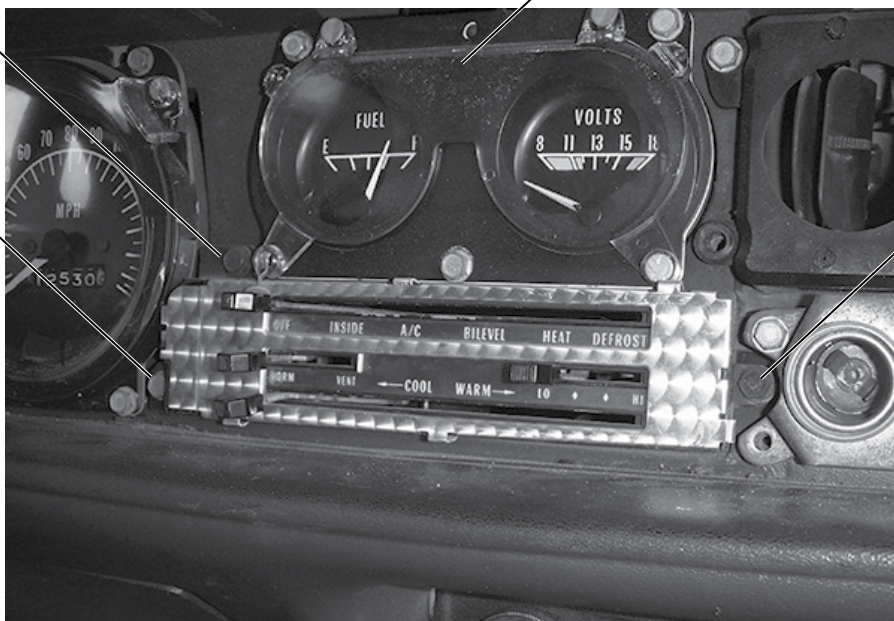

Photo 12

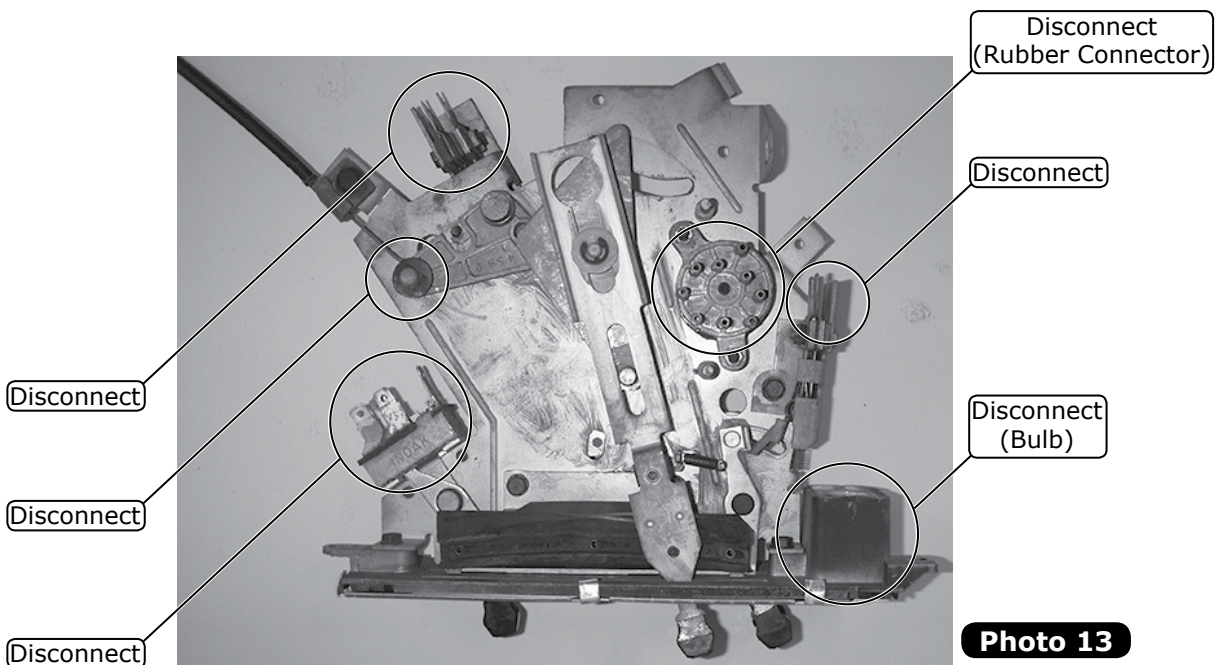

Photo 13



www.vintageair.com

Passenger Compartment Disassembly

Perform the Following:

1. For ease of access in the passenger compartment, remove the passenger seat.
2. Remove the glove box door (retain) (See Figure 1, below).
3. Remove the glove box (discard) (See Figure 1, below).
4. Remove the passenger side kick panel fresh air cover (retain), door vacuum (discard) and passenger side kick panel (retain) (See Figure 3, below).
5. Remove the OEM heater assembly (discard) (See Figure 2, below).
6. Remove all heater assembly ducting (discard).
7. Remove the (2) wires and grommets located on the firewall by the heater/evaporator assembly opening (discard).
8. Remove the OEM defrost ducts (discard) (See Figure 2, below).

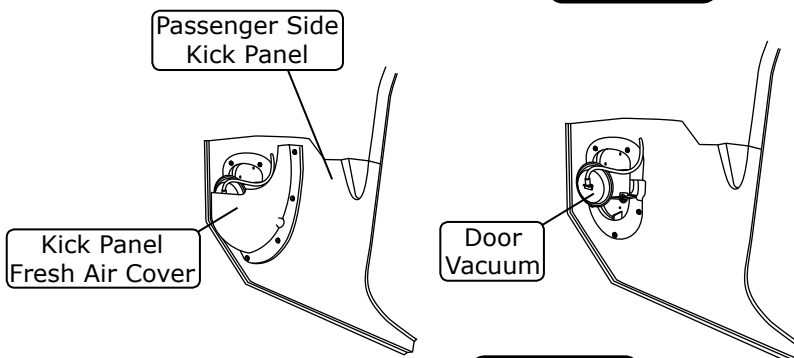
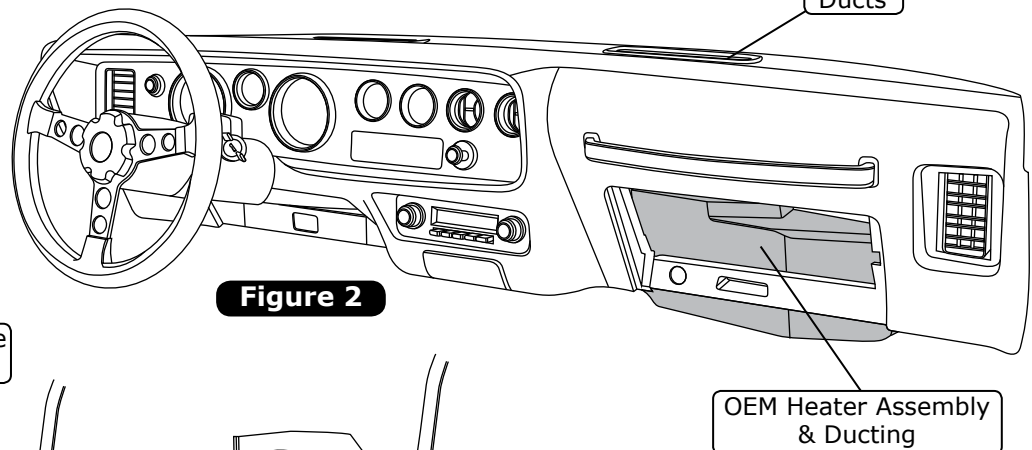
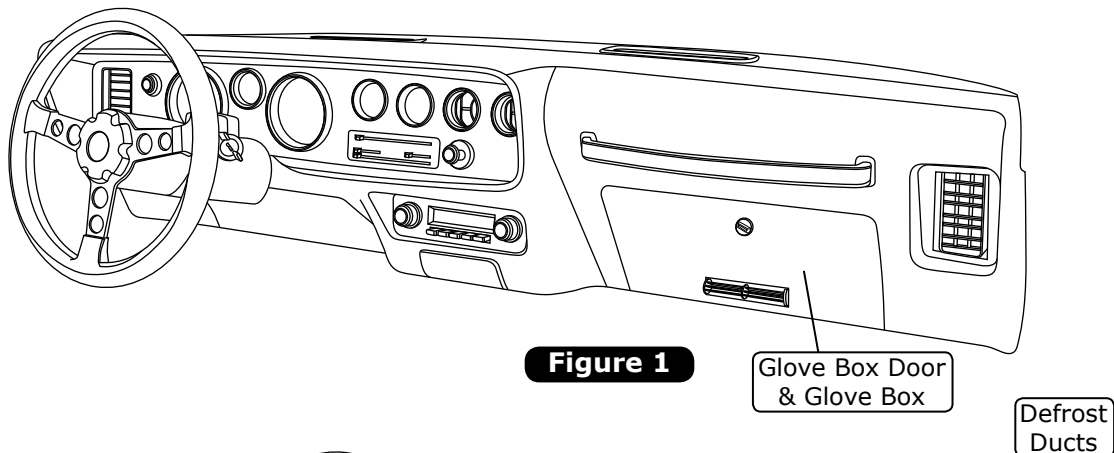

Figure 3



www.vintageair.com

Fresh Air Cap Installation

1. Install (4) grommets in the fresh air cap as shown in Figure 4, below.
2. Apply a 1/4" bead of silicone around the mating surface of the fresh air cap as shown in Figure 4, below.
3. Attach the fresh air cap to the firewall using the fresh air cap bracket, a 1/4-20 x 1 1/2" bolt, and a washer as shown in Figure 4, below. **NOTE: The fresh air cap installs on the engine side of the firewall.**
4. Install plugs into the firewall as shown in Figure 4, below.

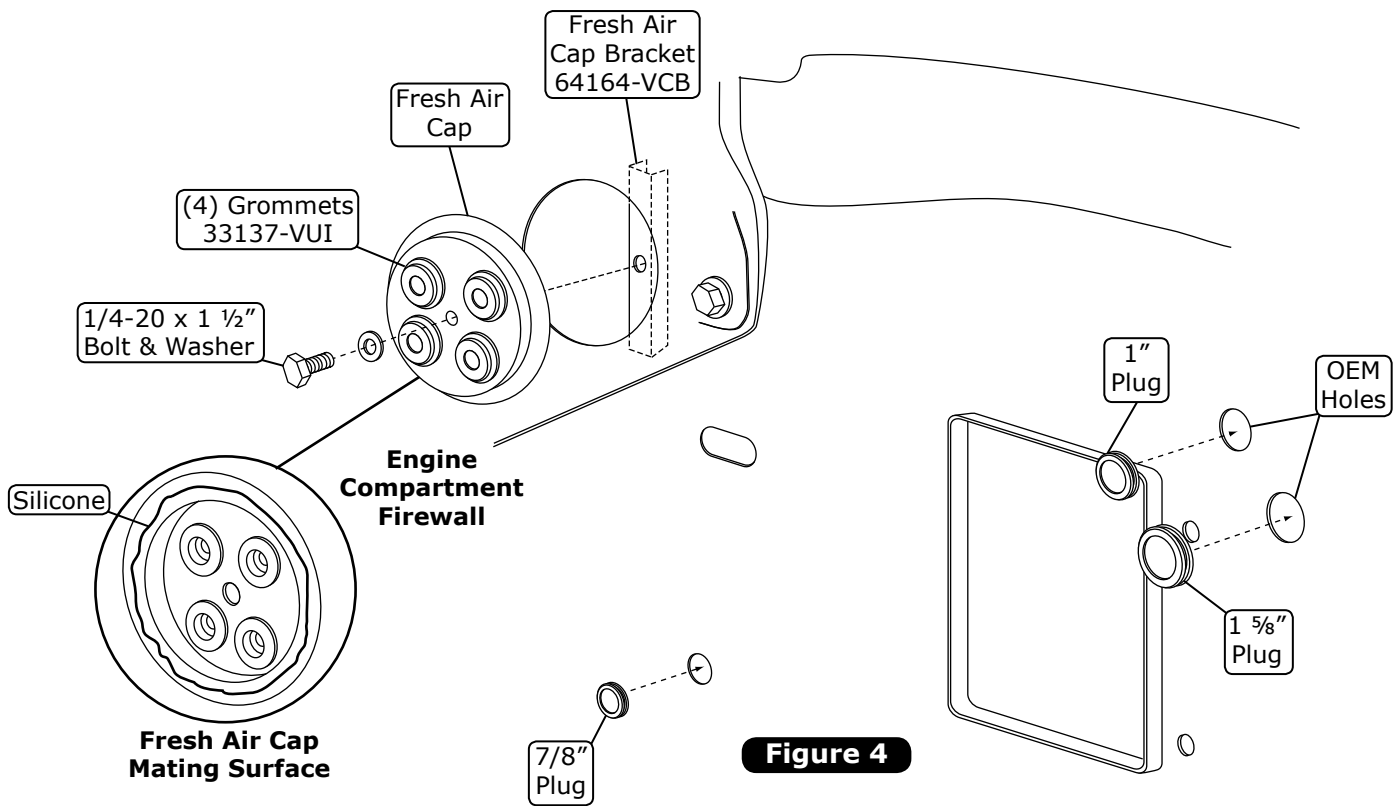

Figure 4

Heater Cover Assembly and Firewall Cover Installation

1. Using the heater cover assembly as a template, mark and drill (2) 5/16" holes in the firewall (See Figure 5, Page 12). **NOTE: Be sure to center the heater cover assembly hole with the OEM hole on the firewall before drilling.**
2. Enlarge (2) OEM holes in firewall to 5/16" (See Figure 5, Page 12).
3. Apply a 1/4" bead of silicone around the mating surface of the firewall cover (See Figure 5, Page 12).
4. From the passenger compartment, install the firewall cover onto the firewall. From the engine compartment, secure the firewall cover to the firewall using (3) 1/4-20 x 1" bolts and washers (See Figure 5, Page 12).
5. Apply a 1/4" bead of silicone around the mating surface of the heater cover assembly (See Figure 5, Page 12).
6. From the passenger compartment, install the heater cover assembly onto the firewall (See Figure 5, Page 12). From the engine compartment, secure the heater cover assembly to the firewall using (2) 1/4-20 x 1/2" bolts and washers (See Figure 5, Page 12). **NOTE: For a finished appearance and a watertight seal, Vintage Air recommends applying a smooth bead of automotive seam sealer in the engine compartment to the joints between the heater and firewall covers and the firewall (See Photos 14 & 15, Page 12).**
7. Install a 3/8" grommet into the center hole of the heater cover, and then route the A/C wires through the grommet (12 volt, ground, binary switch, heater control valve) (See Photo 15, Page 12).



www.vintageair.com

Heater Cover Assembly and Firewall Cover Installation (Cont.)

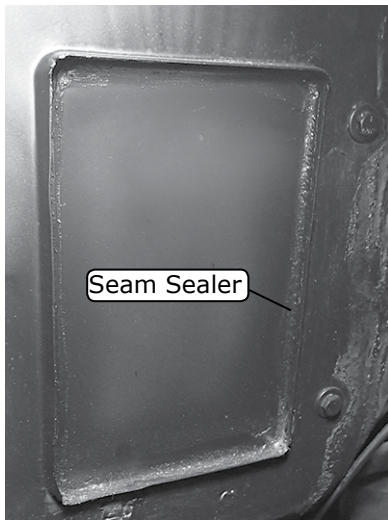

Seam Sealer

Photo 14

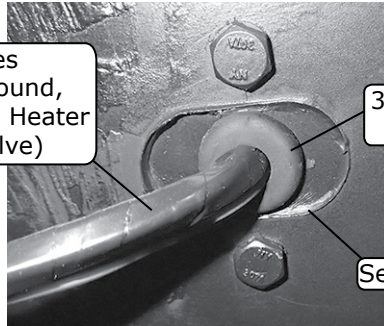

A/C Wires
(12 Volt, Ground,
Binary Switch, Heater
Control Valve)

3/8" Grommet
33144-VUI

Photo 15

Seam Sealer

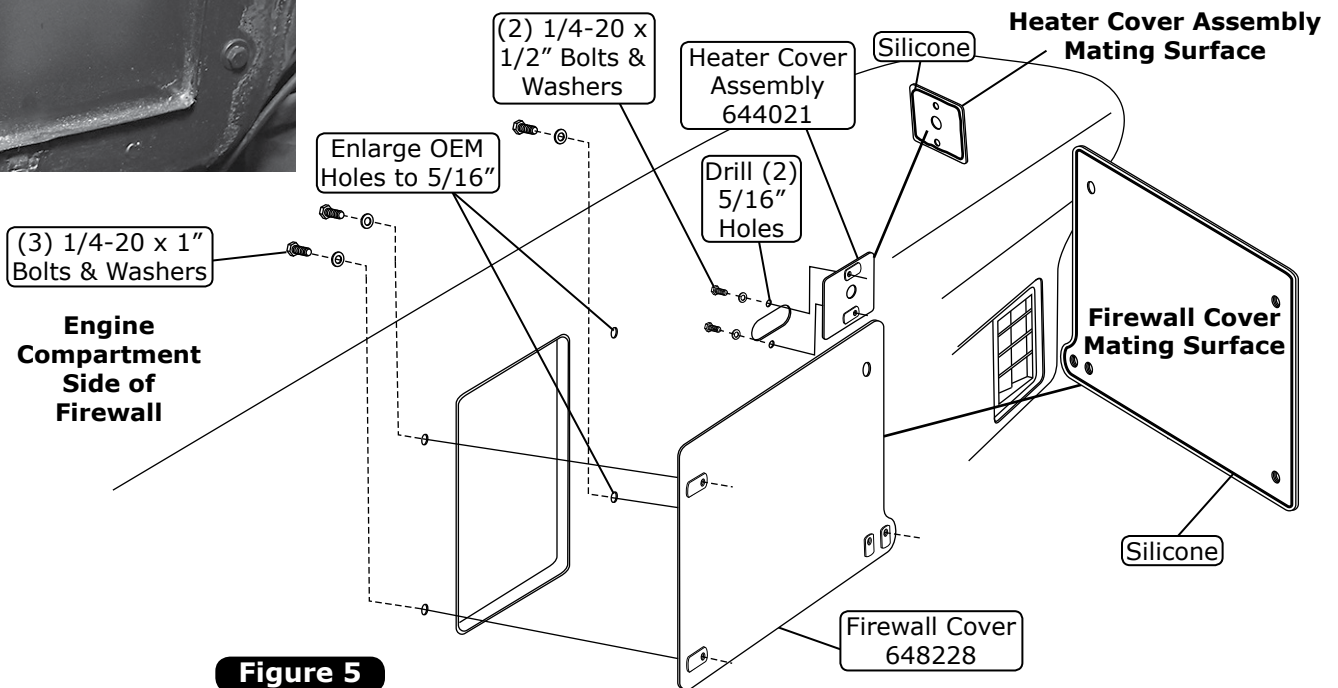

Figure 5

Defrost Duct Installation

1. Secure a 22" length of 2" duct hose onto the driver side defrost duct as shown in Figure 6, below. Secure a 14" length of 2" duct hose onto the passenger side defrost duct.
2. Install the (2) defrost ducts on the OEM defrost duct mounting flanges under the dash using (2) defrost brace brackets, (2) 10-32 x 1/2" screws and (2) 10-32 nuts with star washers as shown in Figure 6, below.

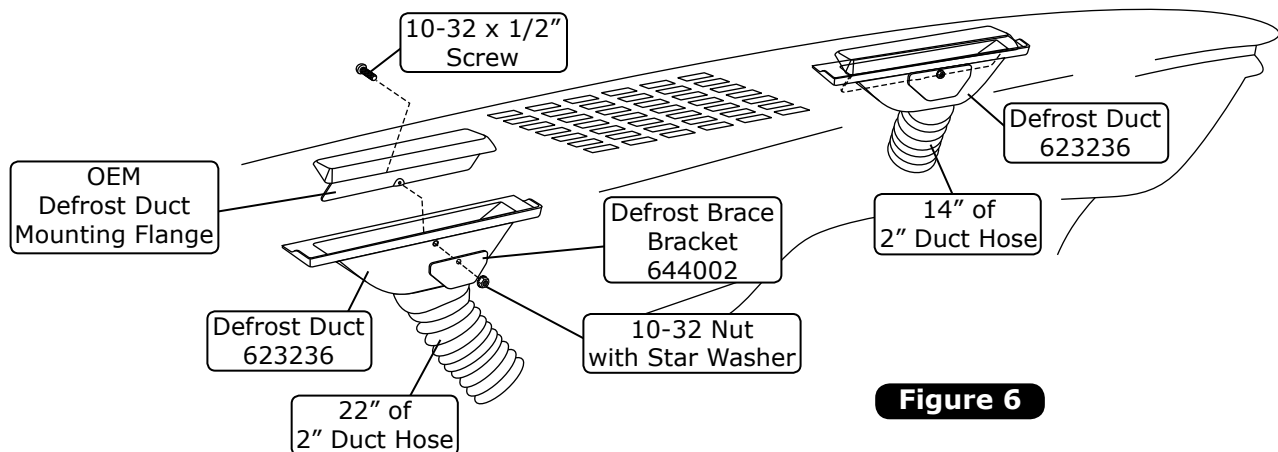

Figure 6



www.vintageair.com

Hose Adapter Installation

1. Locate the driver and passenger side hose adapters.
2. Install (2) S-clips ((1) on each side) onto the driver side hose adapter as shown in Figure 7, below.
3. Secure 36" of 2 1/2" duct hose onto the driver side hose adapter as shown in Figure 7, below.
4. Install the driver side hose adapter onto the back side of the driver side OEM louver as shown in Figure 7, below.
5. Secure 50" of 2 1/2" duct hose onto the passenger side hose adapter as shown in Photo 16, below.
6. Using (3) OEM screws, install the passenger side hose adapter onto the back side of the passenger side louver as shown in Photo 16, below.
7. Locate the center louver hose adapter, and install (2) S-clips ((1) on the center top and (1) on the center bottom) as shown in Figure 8, below.
8. Secure (2) 16" lengths of 2 1/2" duct hose onto the hose adapter as shown in Figure 8, below.
9. Install the hose adapter onto the back side of the OEM center louver as shown in Figure 8, below. **NOTE: Orient the center hose adapter as shown in Figure 8a, below, before installing onto the OEM center louver.**

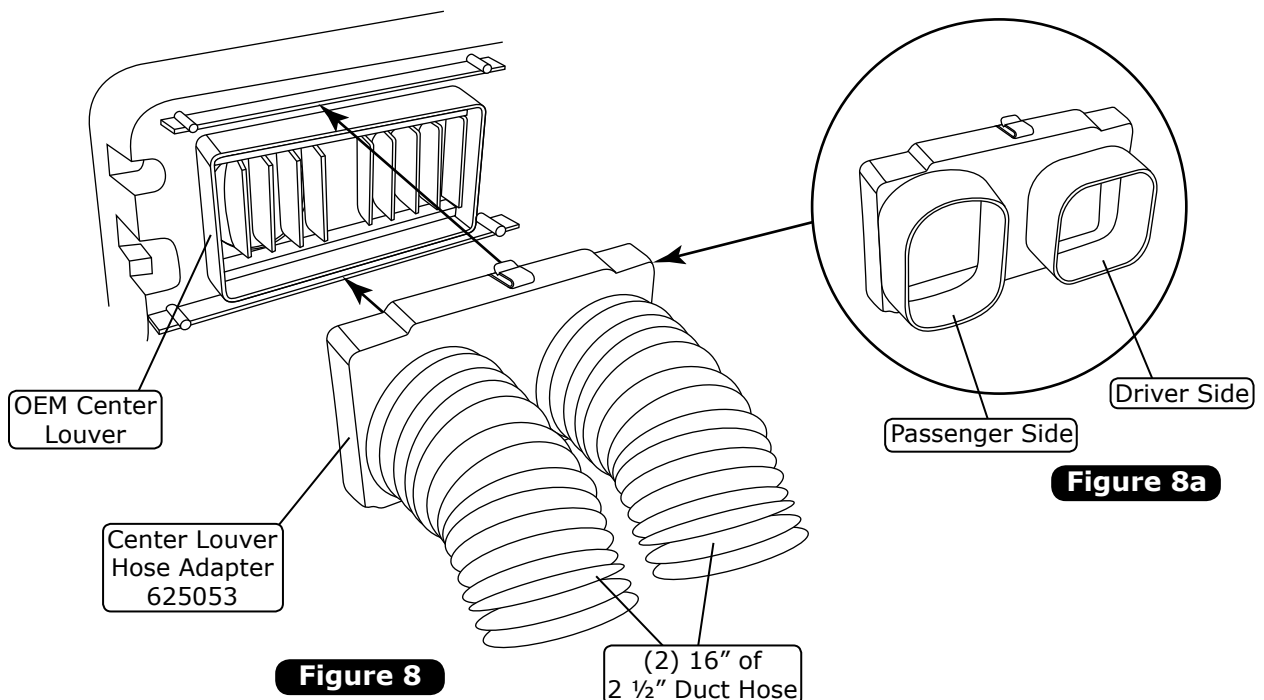
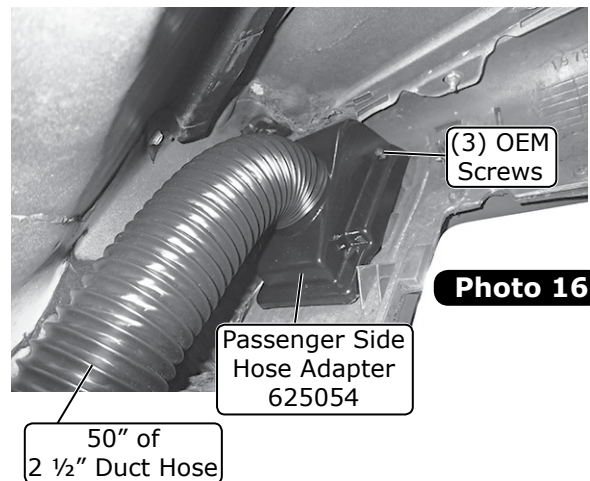
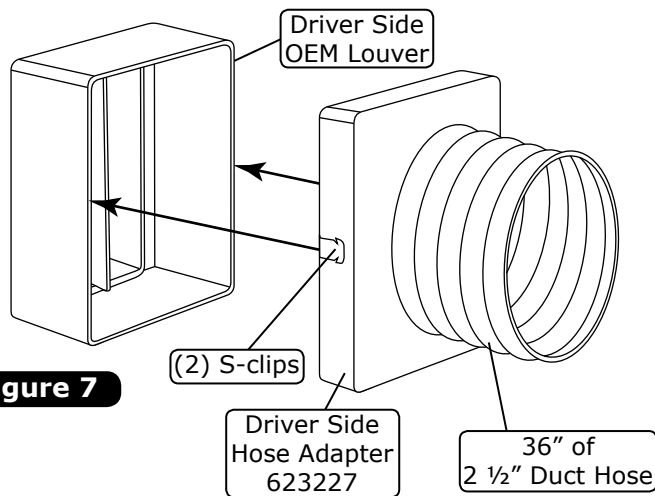



www.vintageair.com

Passenger Side Kick Panel and Fresh Air Cover Modification

1. Locate the OEM passenger side kick panel and kick panel fresh air cover.
2. On the kick panel, mark 3/8" out from the fresh air door assembly lip around the entire perimeter of the fresh air door assembly as shown in Figure 9, below. Cut out the section as shown.
3. Once the evaporator sub case is installed (See Page 15), trim the passenger side kick panel fresh air cover as needed, and secure using OEM screws (See Figure 10, below).

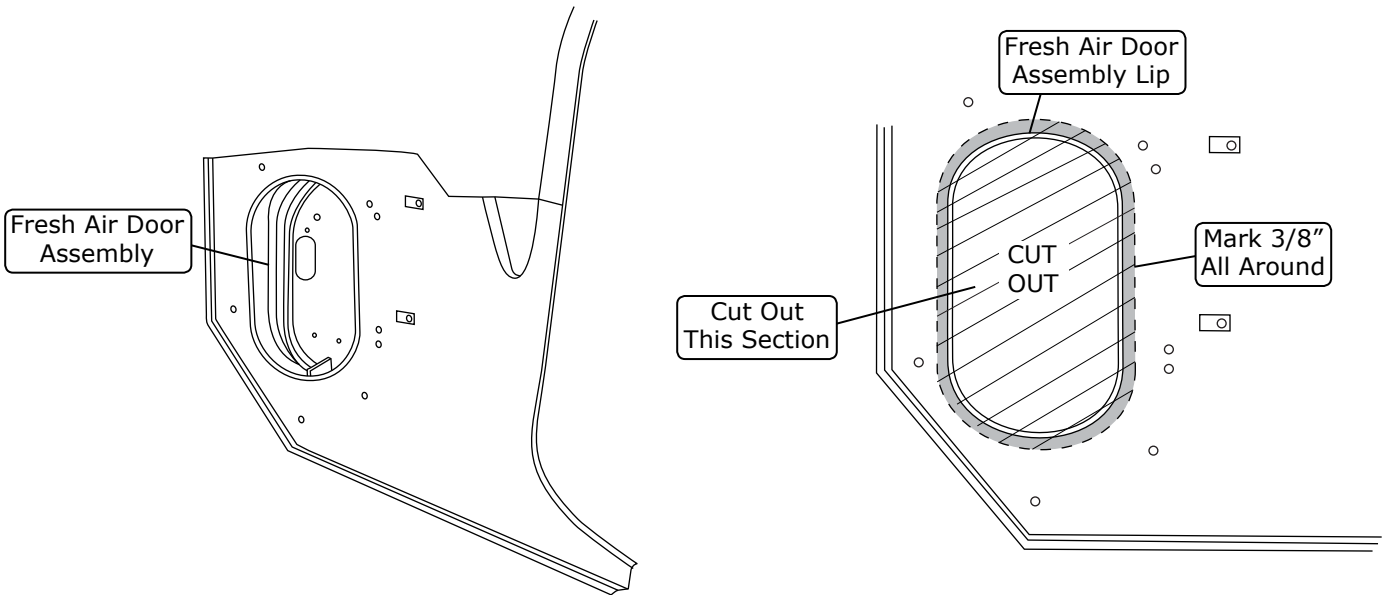

Figure 9

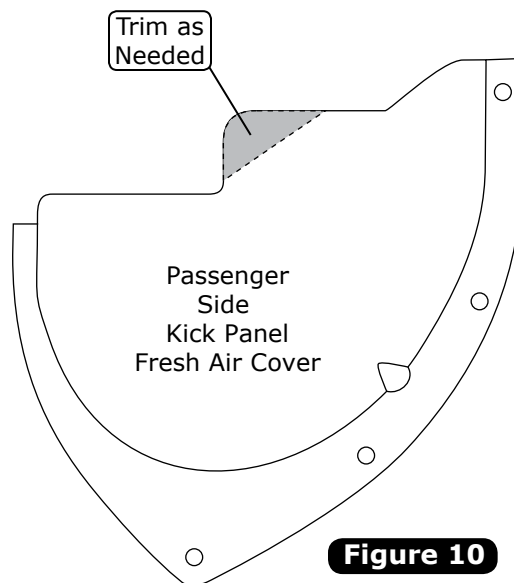

Figure 10



www.vintageair.com

Kick Panel Fresh Air Cap Installation

1. Install (4) grommets into the kick panel fresh air cap as shown in Figure 11a, below.
2. Place the kick panel into position in the passenger compartment. Route the A/C and heater hoses through the fresh air cap, kick panel, and the kick panel fresh air cap as shown in Figures 11 & 11b, below.
3. Apply a 1/4" bead of silicone around the mating surface of the kick panel fresh air cap, and secure using (5) #8 x 1 1/4" countersunk screws with washers as shown in Figures 11a & 11b, below.

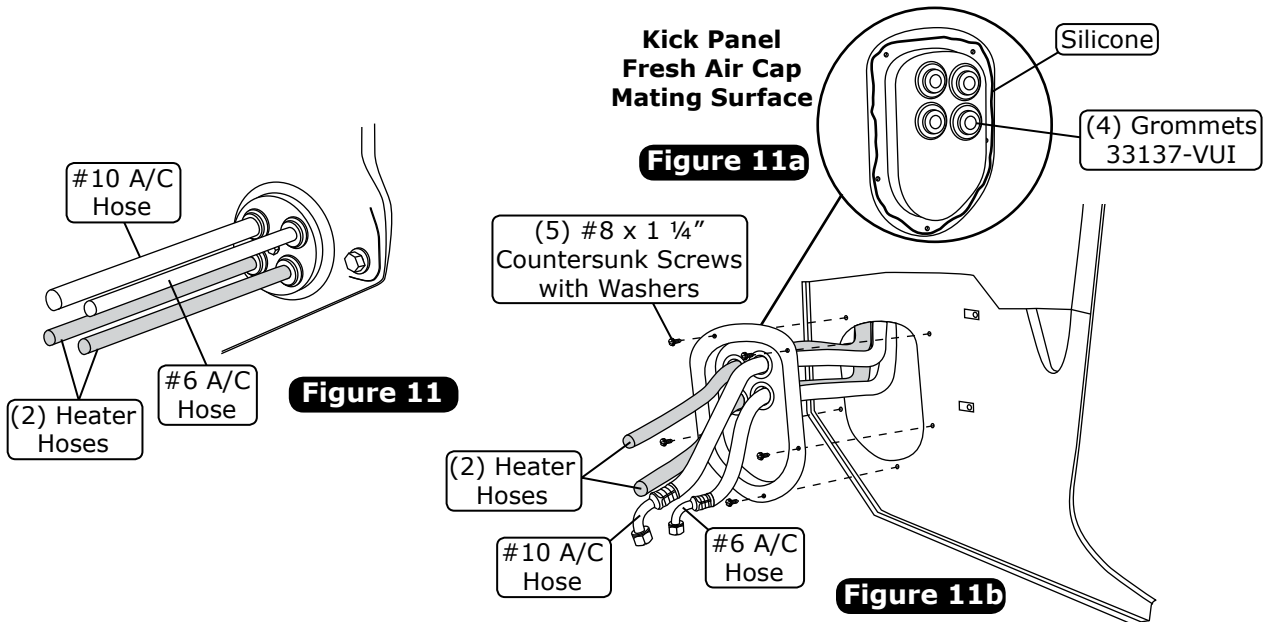

Evaporator Installation

NOTE: To ensure a watertight seal between the passenger compartment and the vehicle exterior, for all bolts passing through the firewall, Vintage Air recommends coating the threads with silicone prior to installation.

1. On a workbench, install the evaporator rear bracket using (2) 1/4-20 x 1/2" bolts (supplied on the evaporator sub case) (See Figure 12, Page 16).
2. Install (2) heater fittings (See Figure 12, Page 16) with properly lubricated O-rings (See Figure 15, Page 18).
3. Place the evaporator unit under the dashboard by the passenger side kick panel, and install the heater hoses and #6 A/C hose (See Figure 13a, Page 17). Use (2) hose clamps on the heater hoses.
4. Lift the evaporator sub case up under the dashboard. Using the bottom hole of the bracket, secure loosely to the firewall using a 1/4-20 x 1" bolt and washer (See Figure 12, Page 16). **NOTE: When lifting up the evaporator sub case, be careful to prevent damage to the drain outlet located at the bottom of the unit. Feed the hoses into or out of the kick panel fresh air cap as needed while lifting the evaporator sub case into position.**
5. Install the #10 A/C hose onto the evaporator (See Figure 13a, Page 17) with properly lubricated O-rings (See Figure 15, Page 18).
6. Install press tape all around the #10 A/C hose fitting as shown in Figure 13a, Page 17.
7. Install the front mounting bracket onto the evaporator using (2) 1/4-20 x 1/2" bolts, and tighten (See Figure 13, Page 17).
8. Using the front mounting bracket as a template, mark and drill (2) 5/32" holes on the inner cowl (See Figure 13, Page 17). **NOTE: To ensure proper drainage, it is very important that the evaporator is level, both left-right and fore-aft. Prior to drilling, check for level on the flat portions of the case around the drain.**
9. Loosely attach the front mounting bracket to the inner cowl using (2) #14 x 3/4" sheet metal screws (See Figure 13, Page 17).
10. Verify that the evaporator unit is level and square to the dash. Then, tighten all mounting bolts. **NOTE: Tighten the bolt on the firewall first. Then tighten the front mounting bracket sheet metal screws.**



Evaporator Installation (Cont.)

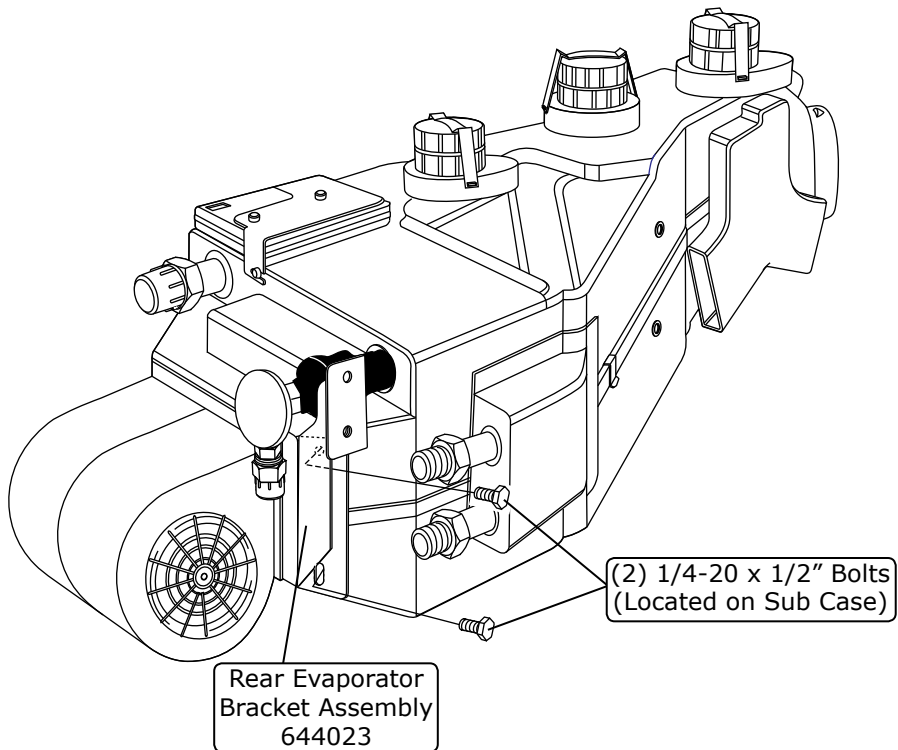
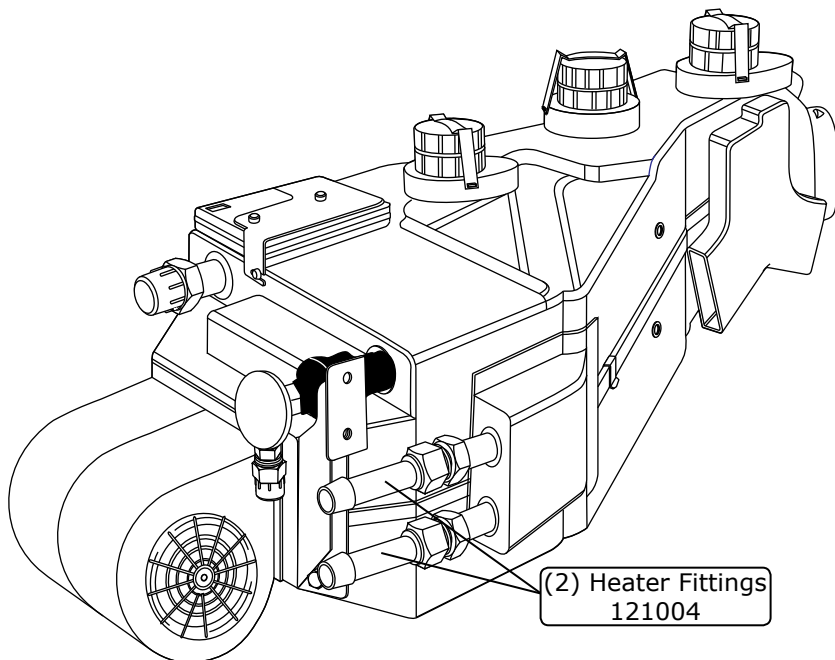
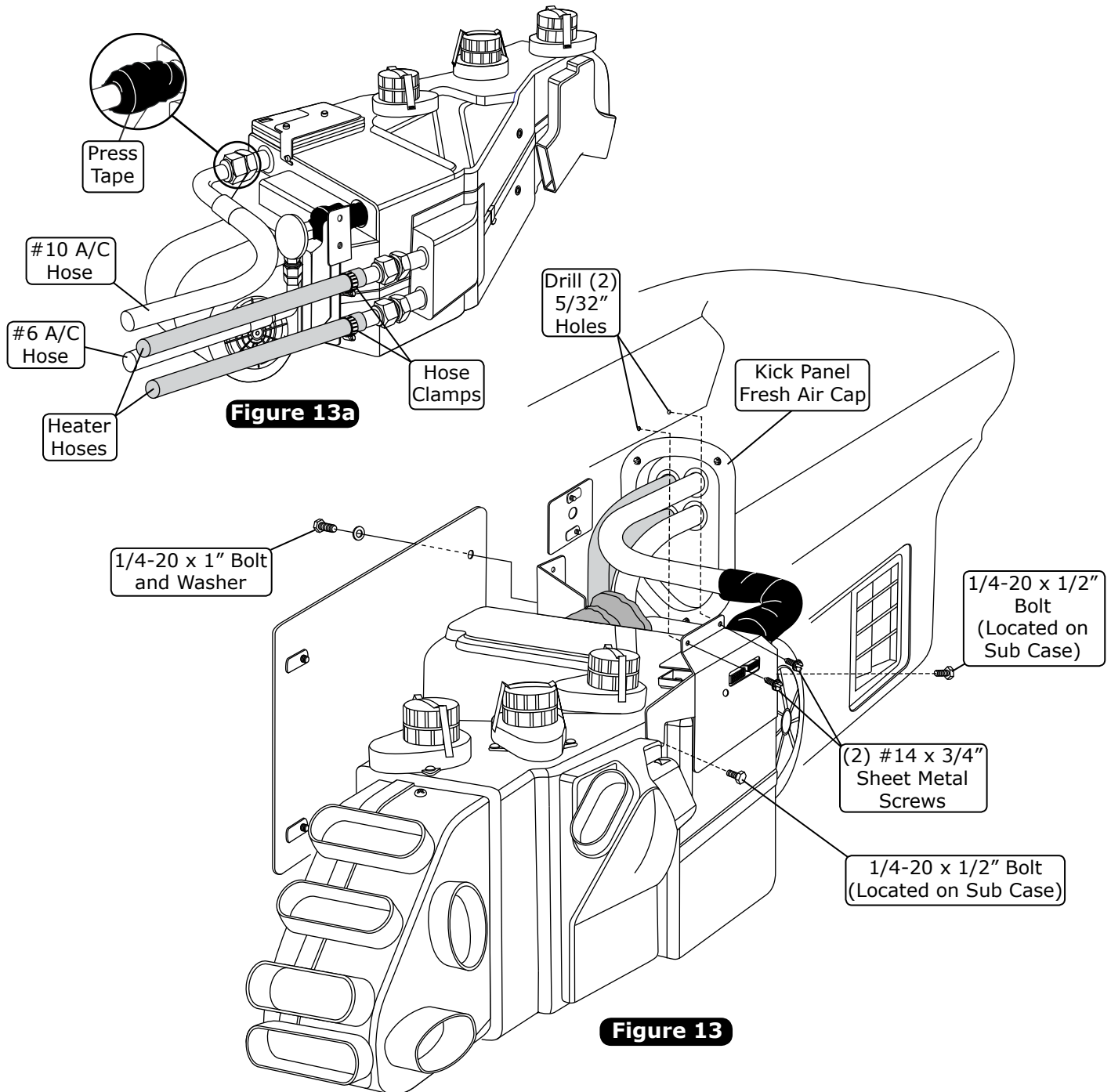

Figure 12





Evaporator Installation (Final)





www.vintageair.com

Drain Hose Installation

1. Locate the evaporator drain on the bottom of the evaporator case.
2. In line with the drain, lightly make a mark on firewall. Then, measure 1" down and drill a 5/8" hole through the firewall (See Figure 14, below).
3. Install the drain hose onto the evaporator drain on the bottom of the unit, and route through the firewall.

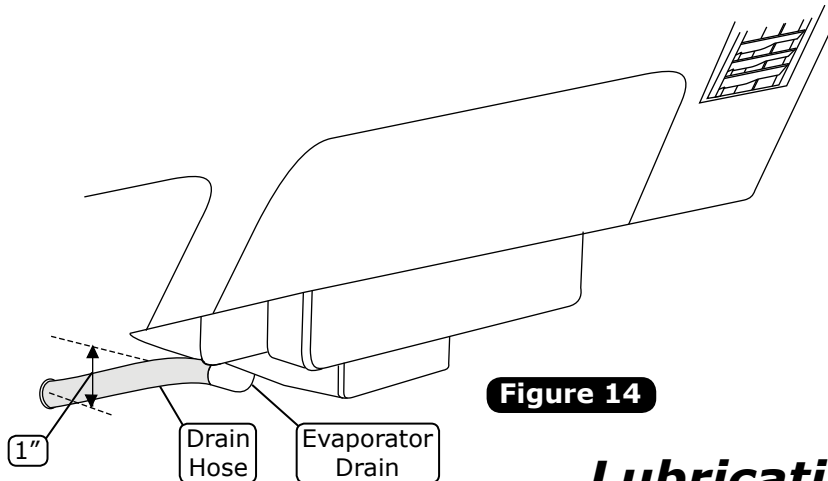

Figure 14

Lubricating O-rings

For a proper seal of fittings: Install supplied O-rings as shown, and lubricate with supplied oil.

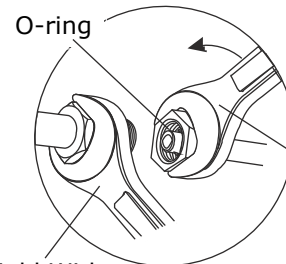
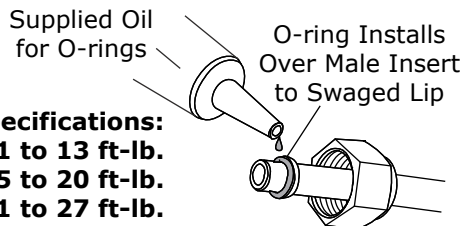
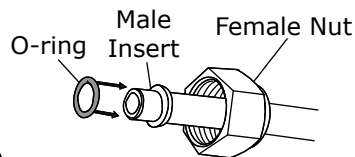
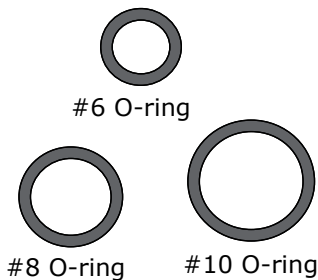

Figure 15

Twist With This Wrench

Hold With This Wrench

NOTE: Standard torque specifications:
#6: 11 to 13 ft-lb.
#8: 15 to 20 ft-lb.
#10: 21 to 27 ft-lb.

A/C Hose Installation

Standard Hose Kit:

1. Locate the #8 compressor A/C hose. Lubricate (2) #8 O-rings (See Figure 15, above) and connect the #8 135° fitting with 134a service port to the #8 discharge port on the compressor (See Photo 17, Page 19). Then route the #8 45° fitting to the #8 condenser hardline coming through the core support (See Photo 17, Page 19). Tighten each fitting connection.
2. Locate the #10 compressor A/C hose. Lubricate (2) #10 O-rings (See Figure 15, above) and connect the #10 135° fitting with 134a service port to the #10 suction port on the compressor (See Photo 17, Page 19). Then route the #10 90° fitting to the #10 fitting on the evaporator (See Figure 13a, Page 17, & Figure 16, Page 19). Tighten each fitting connection.
3. Locate the #6 evaporator A/C hose. Lubricate (2) #6 O-rings (See Figure 15, above) and connect the #6 straight fitting to the #6 hardline coming through the core support from the drier (See Photo 17, Page 19). Then route the #6 90° fitting to the #6 fitting on the evaporator (See Figure 13a, Page 17, & Figure 16, Page 19). Tighten each fitting connection.

Modified Hose Kit:

1. Refer to separate instructions included with modified hose kit.



www.vintageair.com

Heater Hose & Heater Control Valve Installation

1. Route a piece of heater hose from the water pump to the upper heater core fitting (See Photo 17, below, & Figure 13a, Page 17). Secure using hose clamps.
2. Route a piece of heater hose from the intake to the heater control valve, and from the heater control valve to the lower heater core fitting (See Photo 17 & Figure 16, below, & Figure 13a, Page 17). **NOTE: Install the heater control valve in line with the intake manifold (pressure side) heater hose, and secure using hose clamps. Also note proper flow direction.**

A/C and Heater Hose Routing

NOTE: Vintage Air Systems use 5/8" heater connections. On engines equipped with 3/4" hose nipples, these will need to be removed and replaced with 5/8" nipples (not supplied). For water pumps with a cast-in 3/4" heater outlet, a 3/4" x 5/8" reducer fitting (not supplied) will need to be installed in the heater hose.

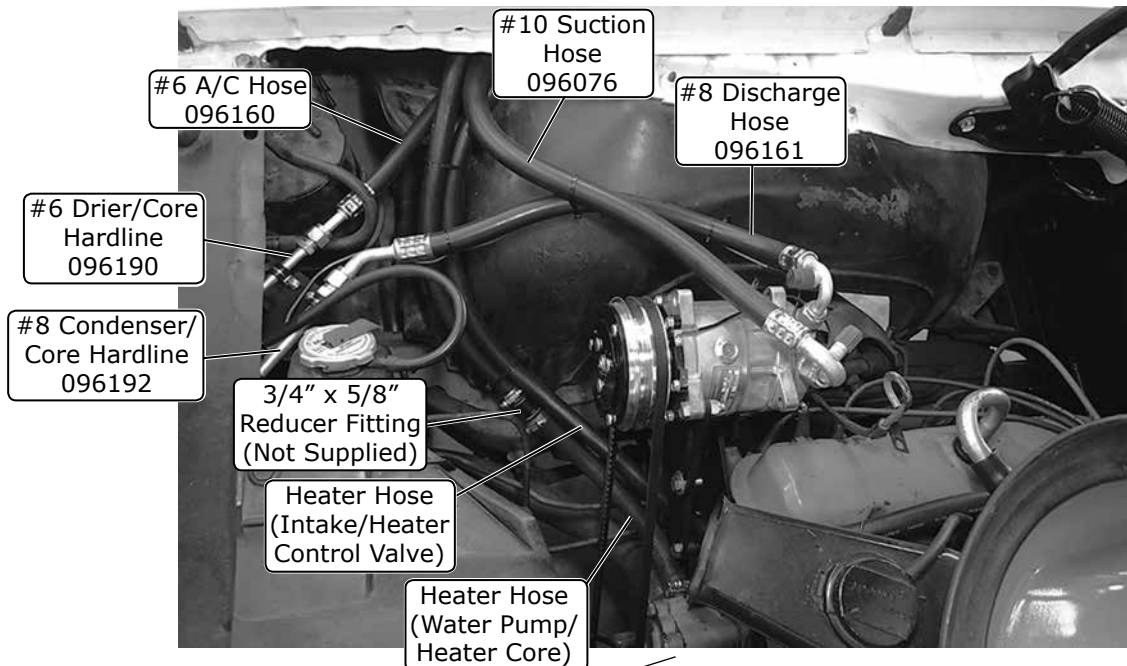

Photo 17

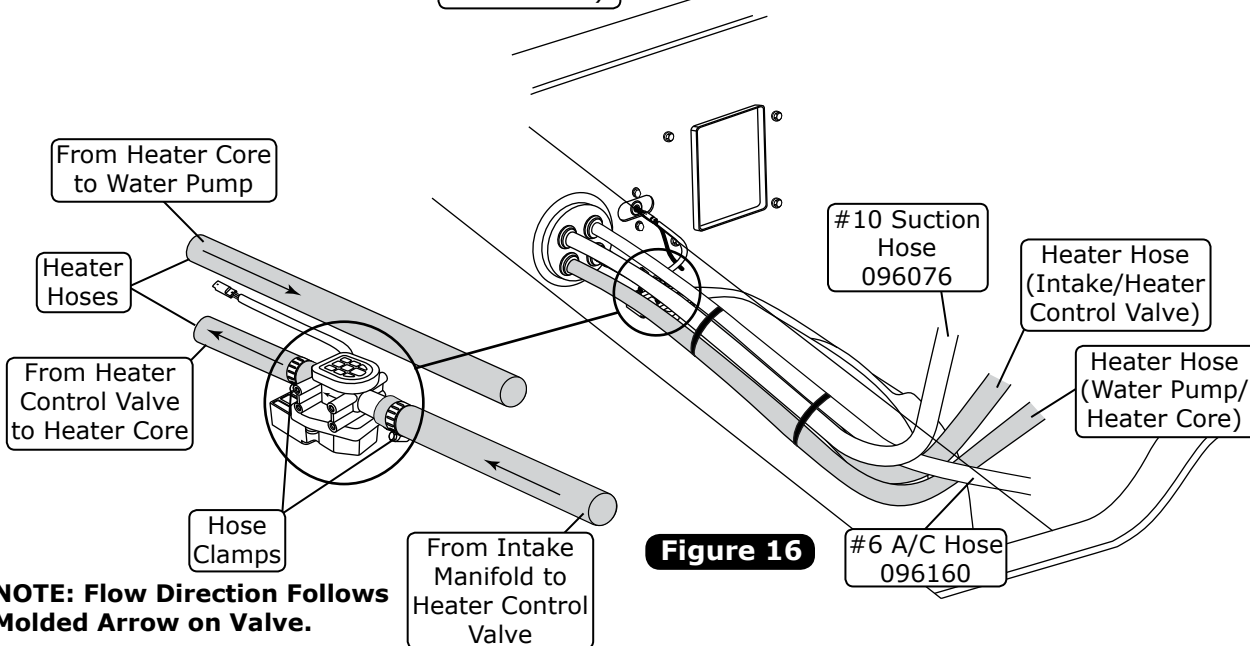

Figure 16

NOTE: Flow Direction Follows Molded Arrow on Valve.



www.vintageair.com

Final Steps

1. Install the duct hoses onto the sub case (See Figure 18, Page 22).
2. Install the control panel assembly. Refer to control panel instructions.
3. Plug the wiring harnesses into the ECU module on the sub case. Wire according to the wiring diagrams on Pages 23 & 24.
4. Refer to the instruction below, and install the driver and passenger side under dash hose adapter assemblies.
5. Refer to the instruction on Page 21, and install the glove box.
6. Refer to the instruction on Page 21, and install the driver side under dash cover.
7. Reinstall all previously removed items.
8. Fill radiator with at least a 50/50 mixture of approved antifreeze and distilled water. It is the owner's responsibility to keep the freeze protection at the proper level for the climate in which the vehicle is operated. Failure to follow antifreeze recommendations will cause heater core to corrode prematurely and possibly burst in A/C mode and/or freezing weather, voiding your warranty.
9. Double check all fittings, brackets and belts for tightness.
10. Vintage Air recommends that all A/C systems be serviced by a licensed automotive A/C technician.
11. Evacuate the system for a minimum of 45 minutes prior to charging, and perform a leak check prior to servicing.
12. Charge the system to the capacities stated on Page 4 of this instruction manual.
13. See Operation of Controls procedures on Page 25.

Under Dash Hose Adapter Assembly Installation

1. Locate the driver side under dash hose adapter assembly, and place it onto the bottom flange of the dash support brace under the steering column (See Figure 17, below). Center the hose adapter assembly onto the opening, and drill a 7/64" hole from the bottom flange of the support brace and through the hose adapter assembly (See Figure 17, below). Secure using a #8 x 1/2" screw (See Figure 17, below).
2. Locate the passenger side under dash hose adapter assembly, and install it onto the A/C duct located on the dash support brace under the glove box (See Figure 17, below). Drill (2) 7/64" holes through the duct and hose adapter assembly (See Figure 17, below). Secure using (2) #8 x 1/2" screws (See Figure 17, below).

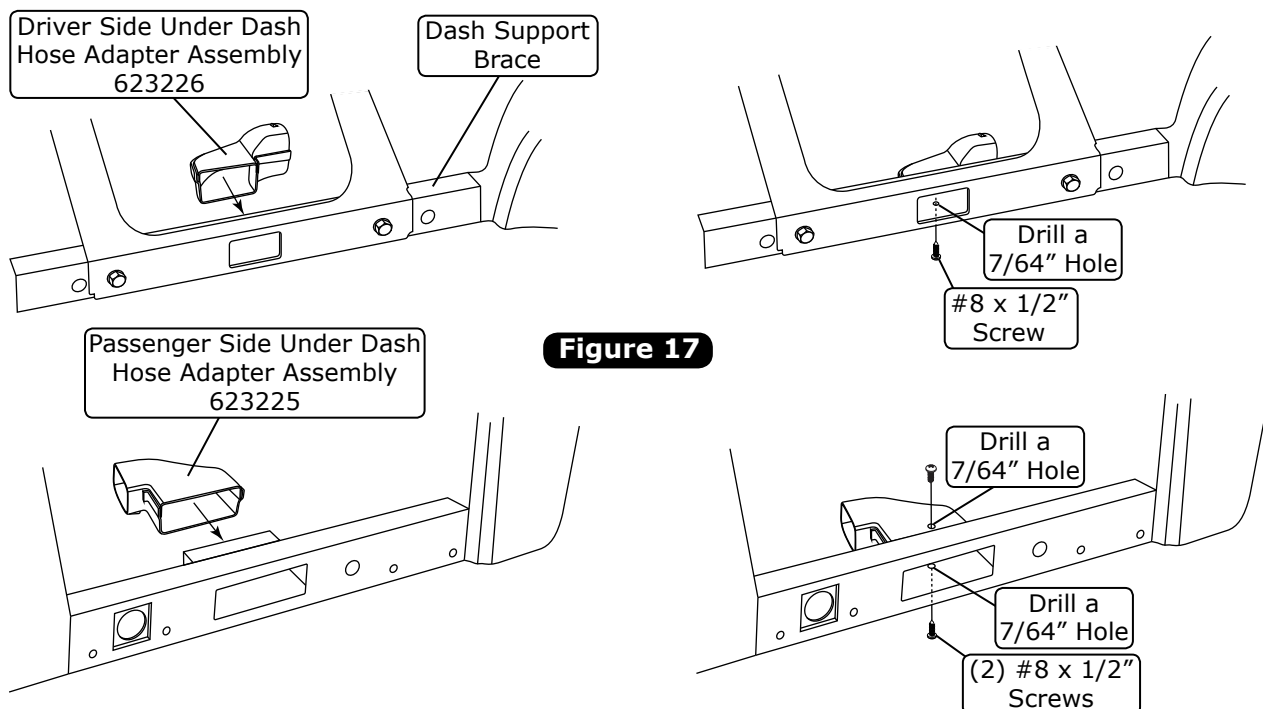

Figure 17



www.vintageair.com

Glove Box Installation

1. Install the new glove box provided with the kit, and secure using OEM screws as shown in Photo 18, below.
2. Reinstall the glove box door.



Photo 18

Driver Side Under Dash Cover Installation

1. Loosen (2) bolts on the dash support brace under the steering column (See Photo 19, below).
2. Install the driver side under dash cover and tighten the screws (See Photo 19, below).
3. Reinstall the OEM plastic steering column cover.

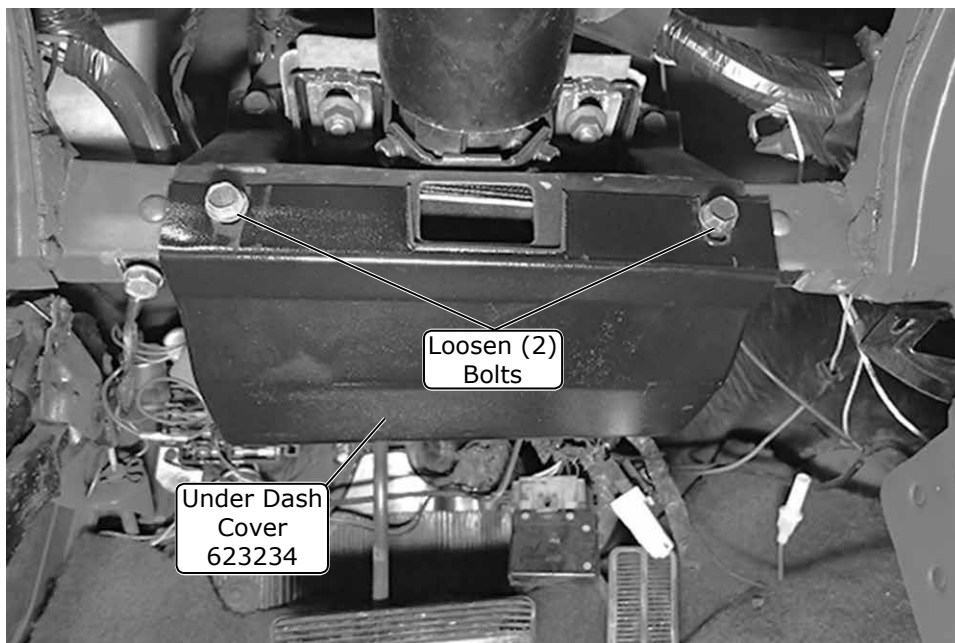

Photo 19



Control Panel & Duct Hose Routing

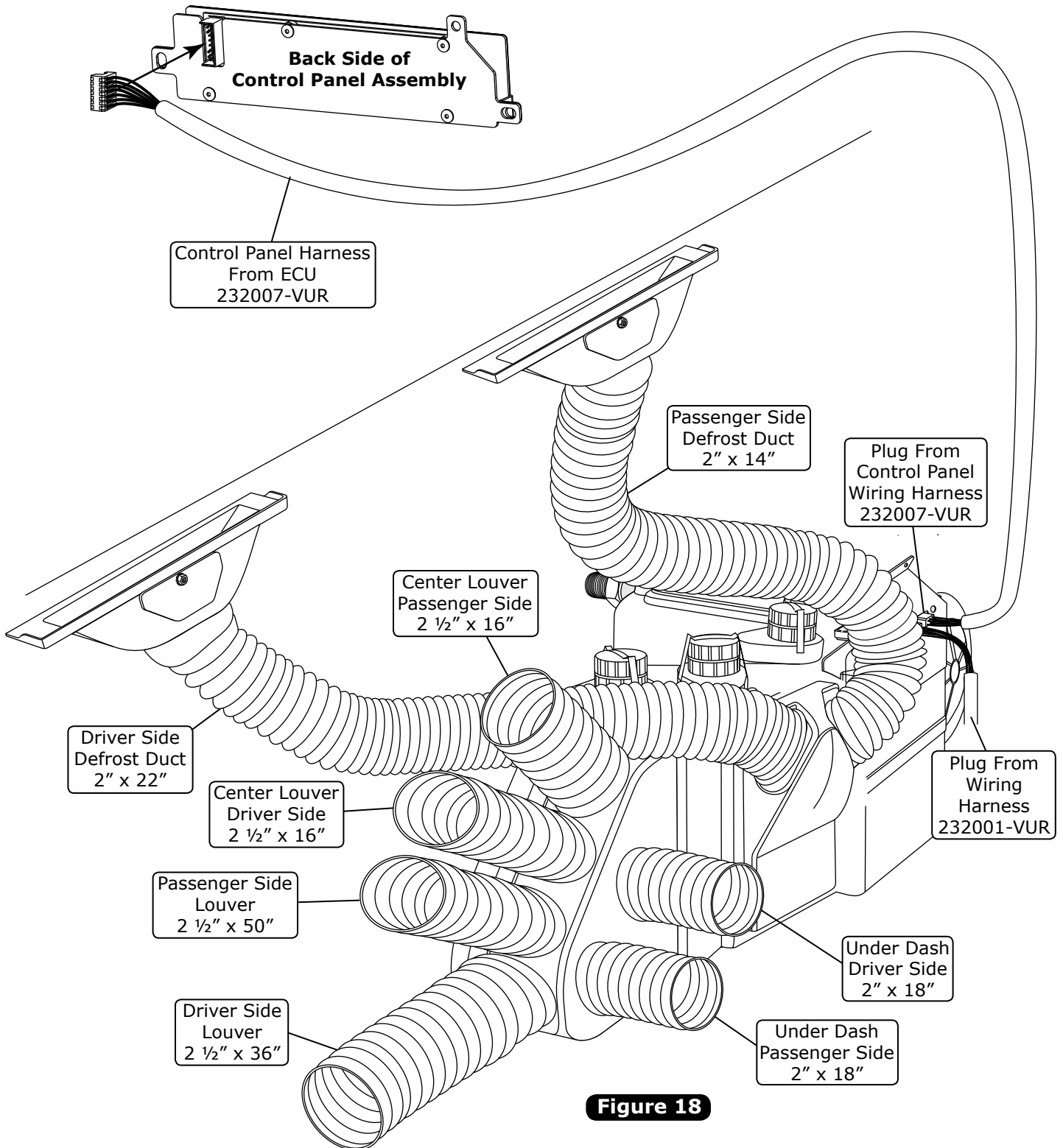

Figure 18



www.vintageair.com

Wiring Diagram

232007-VUR

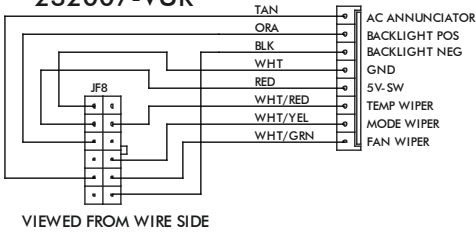

VIEWED FROM WIRE SIDE

232002-VUA

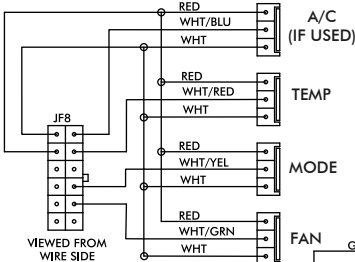

VIEWED FROM WIRE SIDE

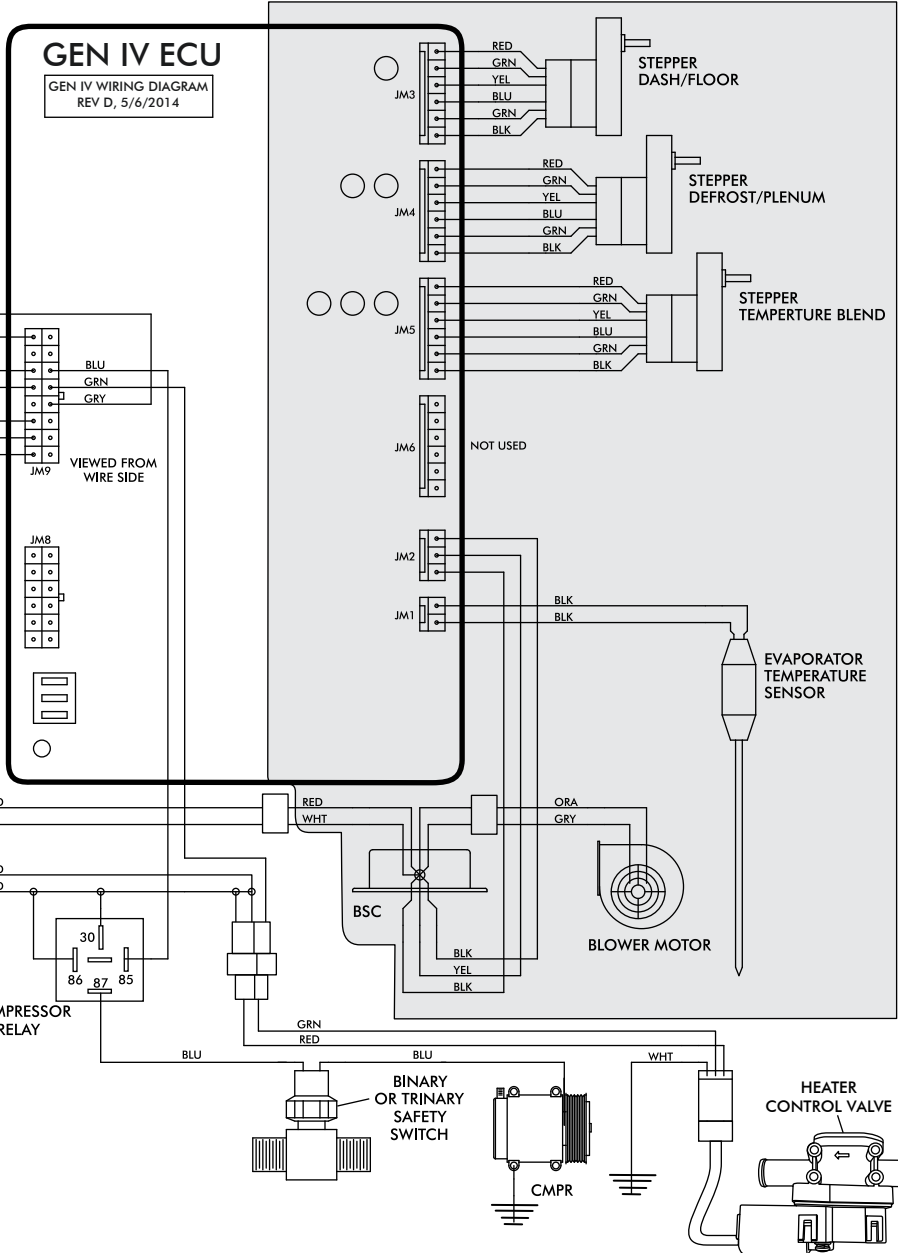

NOTE: = CHASSIS GROUND

- Dash Lamp Is Used Only With Type 232007-VUR Harness.
- Warning: Always Mount Circuit Breaker As Close to the Battery As Possible. (NOTE: Wire Between Battery and Circuit Breaker Is Unprotected and Should Be Carefully Routed to Avoid a Short Circuit).
- Wide Open Throttle Switch Contacts Close Only at Full Throttle, Which Disables A/C Compressor.



www.vintageair.com

Gen IV Wiring Connection Instruction

WIRING HARNESS

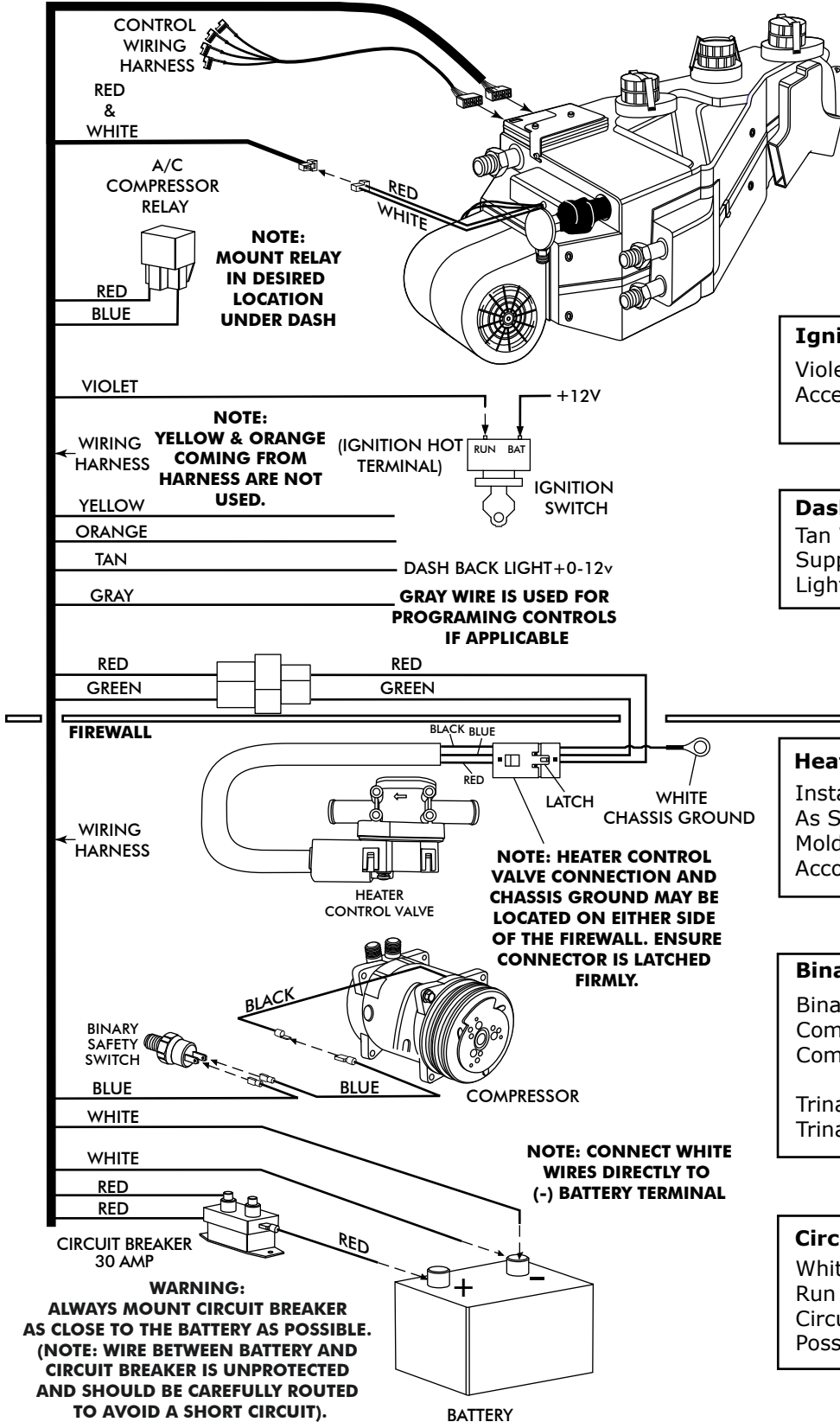

Ignition Switch:
Violet 12V Ign Switch Source (Key On Accessory) Position Must Be Switched.

Dash Light:
Tan Wire Used Only With Vintage Air Supplied Control Panel With LED Back Light.

Heater Control Valve:
Install With Servo Motor Facing Down, As Shown. Note Flow Direction Arrow Molded Into Valve Body, And Install Accordingly.

Binary/Trinary & Compressor:
Binary: Connect As Shown (Typical Compressor Wiring). Be Sure Compressor Body Is Grounded.
Trinary Switch: Connect According To Trinary Switch Wiring Diagram.

Circuit Breaker/Battery:
White **Must** Run To (-) Battery. Red May Run To (+) Battery Or Starter. Mount Circuit Breaker As Close to Battery As Possible.



www.vintageair.com

Operation of Controls

On Gen IV systems with three lever/knob controls, the temperature control toggles between heat and A/C operations. To activate A/C, move the temperature lever/knob all the way to cold and then back it off to the desired vent temperature. For heat operation, move the temperature lever/knob all the way to hot and then adjust to the desired vent temperature. The blower will momentarily change speed, each time you toggle between operations, to indicate the change. **NOTE: For proper control panel function, refer to control panel instructions for calibration procedure.**

Blower Speed

This lever/knob controls blower speed, from OFF to HI.

Mode Control

This lever/knob controls the mode positions, from DASH to FLOOR to DEFROST, with a blend in between.

Temperature Control

This lever/knob controls the temperature, from HOT to COLD.

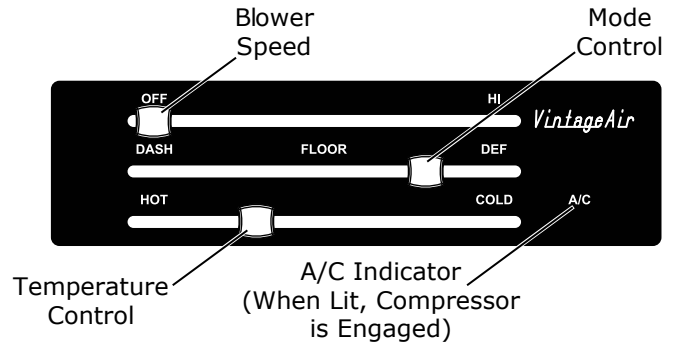

A/C Operation

Blower Speed

Adjust to desired speed.

Mode Control

Adjust to desired mode position (DASH position recommended).

Temperature Control

For A/C operation, adjust to coldest position to engage compressor (Adjust between HOT and COLD to reach desired temperature).



Heat Operation

Blower Speed

Adjust to desired speed.

Mode Control

Adjust to desired mode position (FLOOR position recommended).

Temperature Control

For maximum heating, adjust to hottest position (Adjust between HOT and COLD to reach desired temperature).

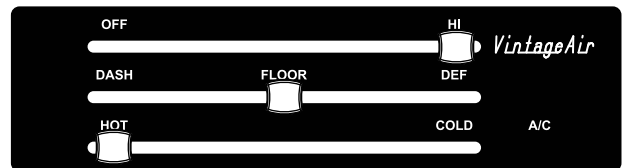

Defrost/De-fog Operation

Blower Speed

Adjust to desired speed.

Temperature Control

Adjust to desired temperature.

Mode Control

Adjust to DEFROST position for maximum defrost, or between FLOOR and DEFROST positions for a bi-level blend (Compressor is automatically engaged).





www.vintageair.com

Troubleshooting Guide

Symptom	Condition	Checks	Actions	Notes
1a. Blower stays on high speed when ignition is on.	No other functions work.	Check for damaged pins or wires in control head plug.	Verify that all pins are inserted into plug. Ensure that no pins are bent or damaged in ECU.	Loss of ground on this wire renders control head inoperable.
	All other functions work.	Check for damaged ground wire (white) in control head harness. Check for damaged blower switch or potentiometer and associated wiring.	Verify continuity to chassis ground with white control head wire at various points.	See blower switch check procedure.
1b. Blower stays on high speed when ignition is on or off.		Unplug 3-wire BSC control connector from ECU. If blower shuts off, ECU is either improperly wired or damaged.	Be sure the small, 20 GA white ground wire is connected to the battery ground post. If it is, replace the ECU.	
		Unplug 3-wire BSC control connector from ECU. If blower stays running, BSC is either improperly wired or damaged.	Check to ensure that no BSC wiring is damaged or shorted to vehicle ground. The BSC operates the blower by ground side pulse width modulation switching. The positive wire to the blower will always be hot. If the "ground" side of the blower is shorted to chassis ground, the blower will run on HI. Replace BSC (This will require removal of evaporator from vehicle).	No other part replacements should be necessary.
2. Compressor will not turn on (All other functions work).	System is not charged.	System must be charged for compressor to engage.	Charge system or bypass pressure switch.	Danger: Never bypass safety switch with engine running. Serious injury can result.
	System is charged.	Check for faulty A/C potentiometer or associated wiring (Not applicable to 3-pot controls). Check for disconnected or faulty thermistor.	Check continuity to ground on white control head wire. Check for 5V on red control head wire. Check 2-pin connector at ECU housing.	To check for proper pot function, check voltage at white/blue wire. Voltage should be between 0V and 5V, and will vary with pot lever position. Disconnected or faulty thermistor will cause compressor to be disabled.
3. Compressor will not turn off (All other functions work).		Check for faulty A/C potentiometer or associated wiring.	Repair or replace pot/control wiring.	Red wire at A/C pot should have approximately 5V with ignition on. White wire will have continuity to chassis ground. White/Blue wire should vary between 0V and 5V when lever is moved up or down.
		Check for faulty A/C relay.	Replace relay.	



www.vintageair.com

Troubleshooting Guide (Cont.)

Symptom	Condition	Checks	Actions	Notes
4.	Works when engine is not running; shuts off when engine is started (Typically early Gen IV, but possible on all versions).	Noise interference from either ignition or alternator.	Install capacitors on ignition coil and alternator. Ensure good ground at all points. Relocate coil and associated wiring away from ECU and ECU wiring. Check for burned or loose plug wires.	Ignition noise (radiated or conducted) will cause the system to shut down due to high voltage spikes. If this is suspected, check with a quality oscilloscope. Spikes greater than 16V will shut down the ECU. Install a radio capacitor at the positive post of the ignition coil (See radio capacitor installation bulletin). A faulty alternator or worn out battery can also result in this condition.
	System will not turn on, or runs intermittently.	Will not turn on under any conditions.	Check for positive power at heater valve green wire and blower red wire. Check for ground on control head white wire.	
		Verify connections on power lead, ignition lead, and both white ground wires.		
		Verify battery voltage is greater than 10 volts and less than 16.	Verify proper meter function by checking the condition of a known good battery.	
5.	Loss of mode door function.	No mode change at all.	Check for damaged mode switch or potentiometer and associated wiring.	Typically caused by evaporator housing installed in a bind in the vehicle. Be sure all mounting locations line up and don't have to be forced into position.
		Partial function of mode doors.	Check for obstructed or binding mode doors.	
			Check for damaged stepper motor or wiring.	
6.	Blower turns on and off rapidly.	Battery voltage is at least 12V.	Check for at least 12V at circuit breaker.	System shuts off blower at 10V. Poor connections or weak battery can cause shutdown at up to 11V.
		Battery voltage is less than 12V.	Check for faulty battery or alternator.	
			Charge battery.	
7.	Erratic functions of blower, mode, temp, etc.	Check for damaged switch or pot and associated wiring.	Repair or replace.	
	When ignition is turned on, blower momentarily comes on, then shuts off. This occurs with the blower switch in the OFF position.	This is an indicator that the system has been reset. Be sure the red power wire is on the battery post, and not on a switched source. Also, if the system is pulled below 7V for even a split second, the system will reset.	Run red power wire directly to battery.	



Packing List: Evaporator Kit (564150)

No.	Qty.	Part No.	Description
1.	1	762171	Gen IV 6-Vent Evaporator Sub Case with 204 ECU
2.	1	781181	Accessory Kit

Checked By: _____
 Packed By: _____
 Date: _____

1

**Gen IV 6-Vent Evaporator
Sub Case
w/ 204 ECU
564150**

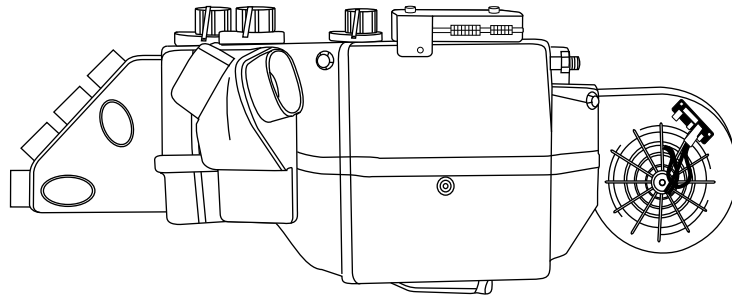

2

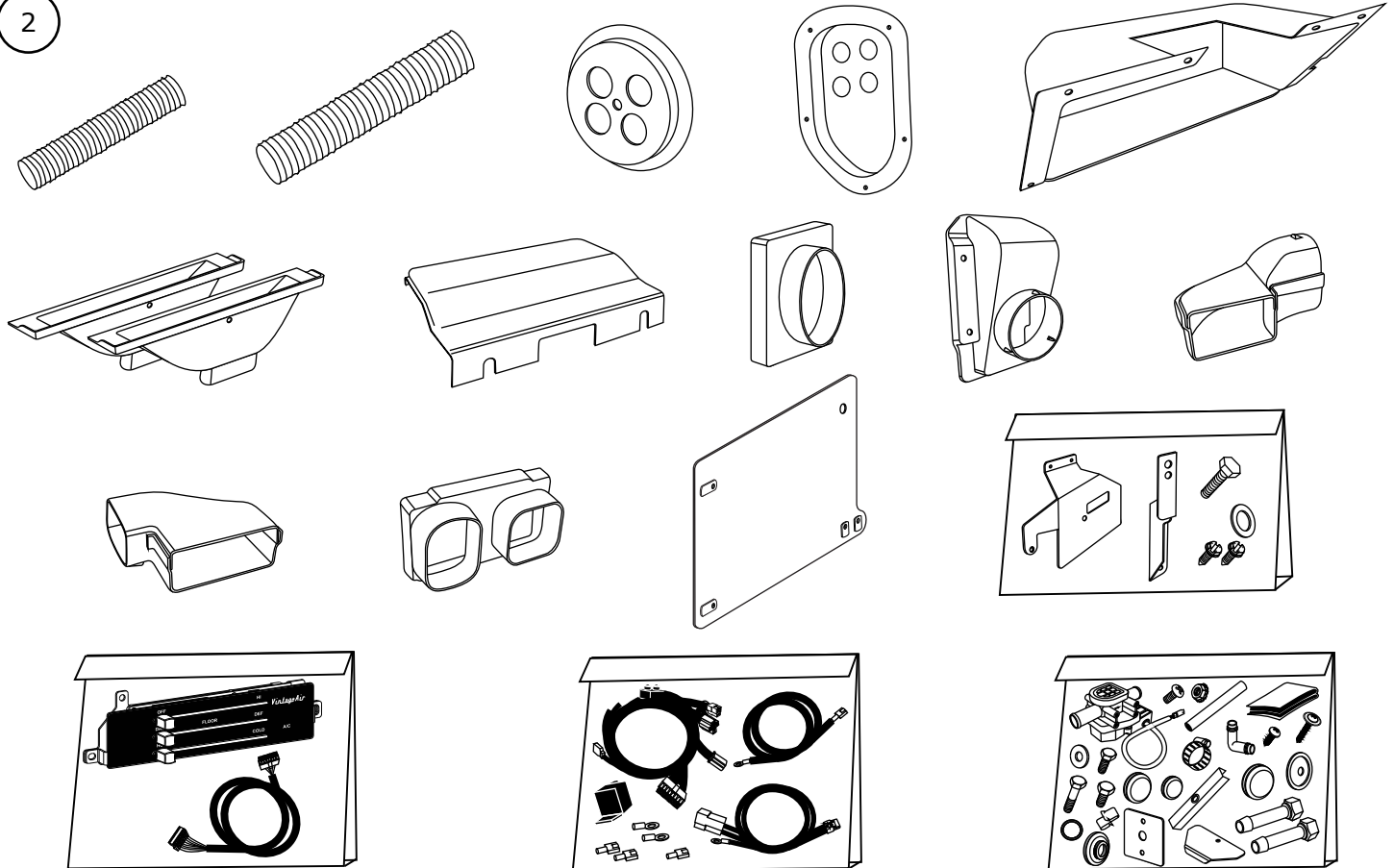

**Accessory Kit
781181**

**NOTE: Images may not depict actual parts and quantities.
Refer to packing list for actual parts and quantities.**