

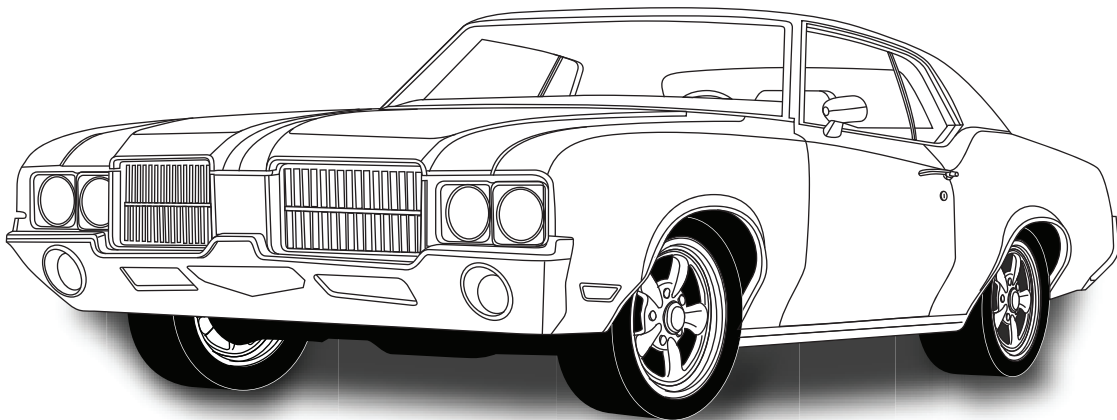

an ISO 9001: 2008 Registered Company

# 1968-69 Cutlass

*with Factory Air*  
**564069**



18865 Goll St. San Antonio, TX 78266 ph: 210-654-7171 fax: 210-654-3113



# Table of Contents

- 1. Cover**
- 2. Table of Contents**
- 3. Packing List / Parts Disclaimer**
- 4. Information Page**
- 5. Wiring Notice**
- 6. Engine Compartment**  
*Figure 1*
- 7. Condenser Assembly, Compressor & Bracket, Pulleys, Passenger Compartment**  
*Figures 2 & 2a*
- 8. Defrost Duct Installation & Hose Adapter Installation**  
*Figures 3 & 4*
- 9. 1968 Center Louver and 1969 Center Louver Installation**  
*Figures 5, 5a, 6 & 6a*
- 10. Fresh Air Cover Installation & Kick Panel Fresh Air Cap Installation**  
*Figures 7, 8, 8a & 8b*
- 11. Firewall Cover Installation & Evaporator Installation**  
*Figures 9 & 10*
- 12. Bracket Installation Cont.**  
*Figure 11*
- 13. Evaporator Installation Cont.**  
*Figures 12 & 13*
- 14. Drain Hose Installation Lubricating O-rings, A/C Hose Installation**  
*Figures 14 & 15*
- 15. A/C & Heater Hose Routing**  
*Figure 16*
- 16. Final Steps, Glove Box And Passenger Side Kick Panel Modification**  
*Figures 17,18 & 19*
- 17. Control Panel & Duct Hose Routing**  
*Figures 20 & 21*
- 18. Wiring Diagram**
- 19. Gen IV Wiring Connection Instructions**
- 20. Operation of Controls**
- 21. Troubleshooting Information**
- 22. Troubleshooting Information Cont.**
- 23. Evaporator Kit Packing List**



## Packing List Evaporator Kit (564069)

No.	QTY.	PART No.	DESCRIPTION
1.	1	744004-VUE	Gen IV 4-Vent Evap. Sub Case w/ 204 ECU
2.	1	784070	1968-69 Cutlass with A/C Acc. Kit

**\*\* Before beginning installation, open all packages and check contents of shipment. Please report any shortages directly to Vintage Air within 15 days. After 15 days, Vintage Air will not be responsible for missing or damaged items.**

①

**Gen IV 4-Vent  
Evap Sub Case  
w/204 ECU  
744004-VUE**

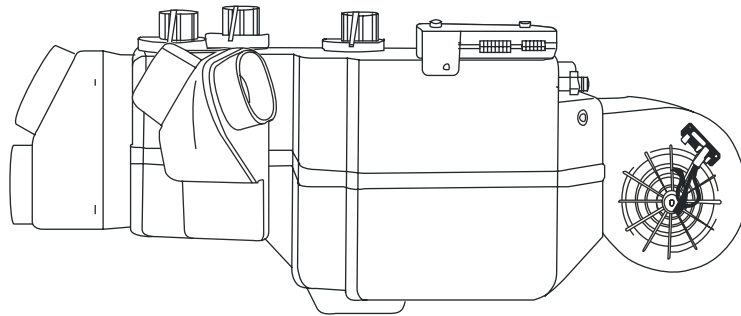

②

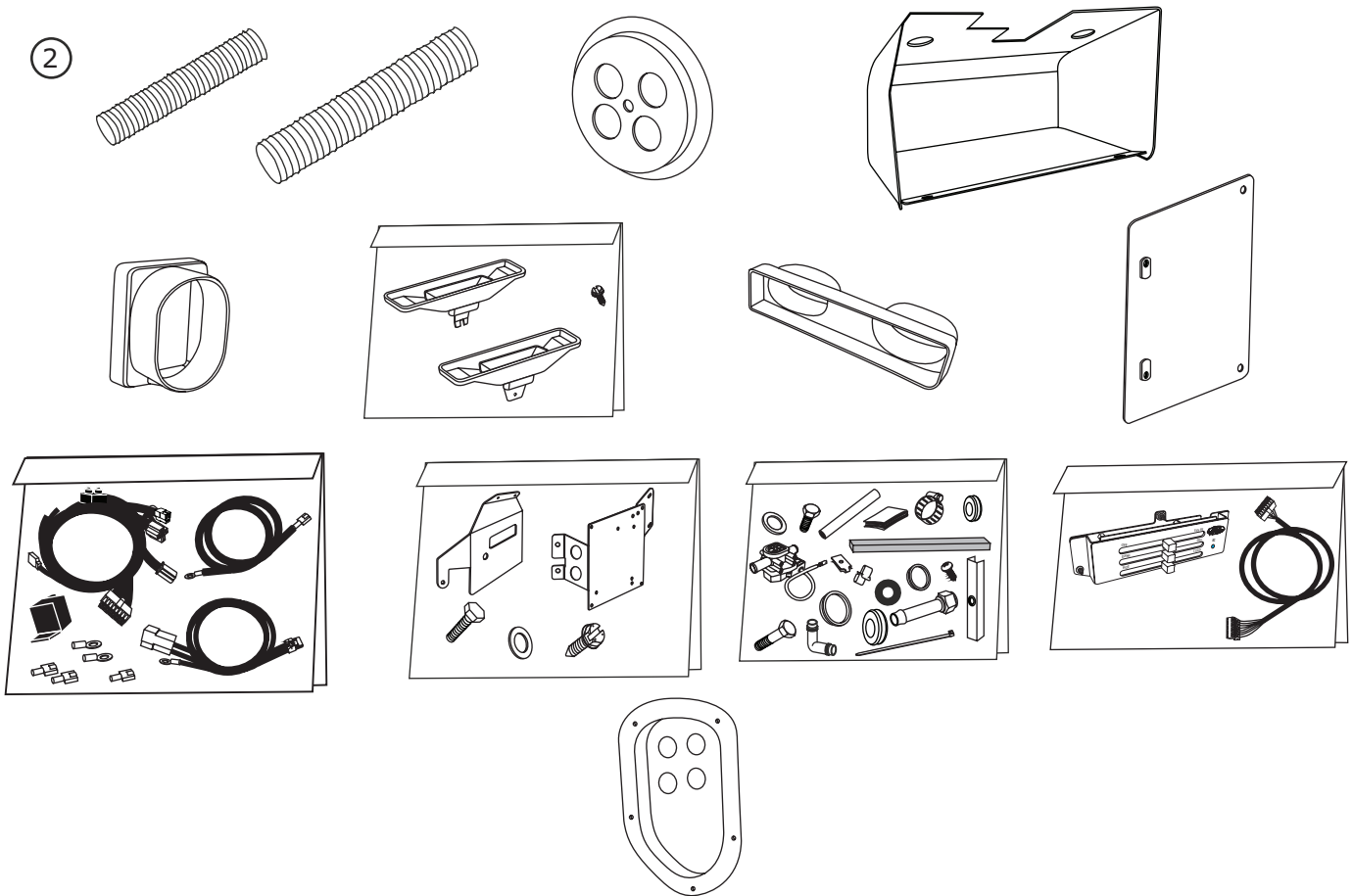

**Accessory Kit  
784070**

**NOTE: Images may not depict actual parts and quantities. Refer to packing list for actual parts and quantities.**

3



## Important Notice—Please Read

***For Maximum System Performance, Vintage Air Recommends the Following:***

### **Heater Hose (Not Included With This Kit):**

Heater hose may be purchased from Vintage Air (Part# 31800-VUD) or your local parts retailer. Routing and required length will vary based on installer preference.

### **Bolts Passing Through Cowl and/or Firewall:**

To ensure a watertight seal between the passenger compartment and the vehicle exterior, for all bolts passing through the cowl and/or firewall, Vintage Air recommends coating the threads with silicone prior to installation.

### **Safety Switches:**

Your Vintage Air system is equipped with a binary pressure safety switch. A binary switch disengages the compressor clutch in cases of extreme low pressure conditions (Refrigerant Loss) or excessively high head pressure (406 PSI) to prevent compressor damage or hose rupture. A trinary switch combines Hi/Lo pressure protection with an electric fan operation signal at 254 PSI, and should be substituted for use with electric fans. Compressor safety switches are extremely important since an A/C system relies on refrigerant to circulate lubricant.

### **Service Info:**

**Attention:** The following system components are capped: Compressor, evaporator, condenser & drier. Caps may be under pressure with dry nitrogen. Be careful removing caps. Do not remove caps prior to installation. Removing caps prior to installation will cause components to collect moisture and lead to premature failure and reduced performance.

Evacuate the system for 35-45 minutes with system components (Drier, compressor, evaporator and condenser) at a temperature of at least 85° F. On a cool day, the components can be heated with a heat gun OR by running the engine with the heater on before evacuating. Leak check and charge to specifications.

***Vintage Air Systems Are Designed to Operate With R134a Refrigerant Only! Use of Any Other Refrigerants Is a Fire Hazard and Could Damage Either Your Air Conditioning System or Your Vehicle.***

***Use of Any Other Refrigerants Will Void All Warranties of the Air Conditioning System and Components. Use of the Proper Type and Amount of Refrigerant Is Critical to Proper System Operation. Vintage Air Recommends Our Systems Be Charged By Weight With a Quality Charging Station or Scale.***

### **Refrigerant Capacity for Vintage Air Systems:**

*(For other systems, consult manufacturer's guidelines)*

#### **R134a System**

Charge with 1.8 lbs. (1 lb., 12 oz.) of refrigerant.

### **Lubricant Capacities:**

**New Vintage Air-supplied Sanden Compressor:** No additional oil needed (Compressor is shipped with proper oil charge).

**All Other Compressors:** Consult manufacturer (Some compressors are shipped dry and will need oil added).



## Important Wiring Notice—Please Read

*Some Vehicles May Have Had Some or All of Their Radio Interference Capacitors Removed. There Should Be a Capacitor Found At Each of the Following Locations:*

- 1. On the positive terminal of the ignition coil.**
- 2. If there is a generator, on the armature terminal of the generator.**
- 3. If there is a generator, on the battery terminal of the voltage regulator.**

Most alternators have a capacitor installed internally to eliminate what is called "whining" as the engine is revved. If whining is heard in the radio, or just to be extra cautious, a radio interference capacitor can be added to the battery terminal of the alternator.

It is also important that the battery lead is in good shape and that the ground leads are not compromised. There should be a heavy ground from the battery to the engine block, and additional grounds to the body and chassis.

If these precautions are not observed, it is possible for voltage spikes to be present on the battery leads. These spikes come from ignition systems, charging systems, and from switching some of the vehicle's other systems on and off. Modern computer-operated equipment can be sensitive to voltage spikes on the power leads, which can cause unexpected resets, strange behavior, and/or permanent damage.

Vintage Air strives to harden our products against these types of electrical noise, but there is a point where a vehicle's electrical system can be degraded so much that nothing can help.

Radio interference capacitors should be available at most auto and truck parts suppliers. They typically are cylindrical in shape, a little over an inch long, a little over a half inch in diameter, and they have a single lead coming from one end of the cylinder with a terminal on the end of the wire, as well as a mounting clip which is screwed into a good ground on the vehicle. The specific value of the capacitance is not too significant in comparison to ignition capacitors that are matched with the coil to reduce pitting of the points.

- Care must be taken, when installing the compressor lead, not to short it to ground. The compressor lead must not be connected to a condenser fan or to any other auxiliary device. Shorting to ground or connecting to a condenser fan or any other auxiliary device may damage wiring, the compressor relay, and/or cause a malfunction.
- When installing ground leads on Gen IV systems, the blower control ground and ECU ground must be connected directly to the negative battery post.
- For proper system operation, the heater control valve must be connected to the ECU.



## Engine Compartment

**NOTE:** Before starting the installation, check the function of the vehicle (horn, lights, etc.) for proper operation, and study the instructions, illustrations, & diagrams.

### Remove the Following:

1. Disconnect battery.
2. Battery (retain).
3. Drain radiator & remove radiator.
4. Evacuate the A/C system if necessary.
5. OEM Condenser and drier (discard) (See Figure 1, below).
6. OEM A/C lines from compressor to evaporator (discard) (See Figure 1, below).
7. OEM Compressor and bracket (discard) (See figure 1).
8. Evaporator blower assembly (Discard). **NOTE: To remove the evaporator and blower assembly (under hood) and the air distribution system (under dash) the factory manual indicates doing the following: Remove right inner fender.**
9. OEM heater hoses, A/C hoses, hardlines and drier (discard). (See Figure 1, below)
10. OEM A/C & heater wiring/vacuum harness molded grommet. (See Figure 1, below)
11. Install 1 3/4" plug in firewall. (See Figure 1, below)

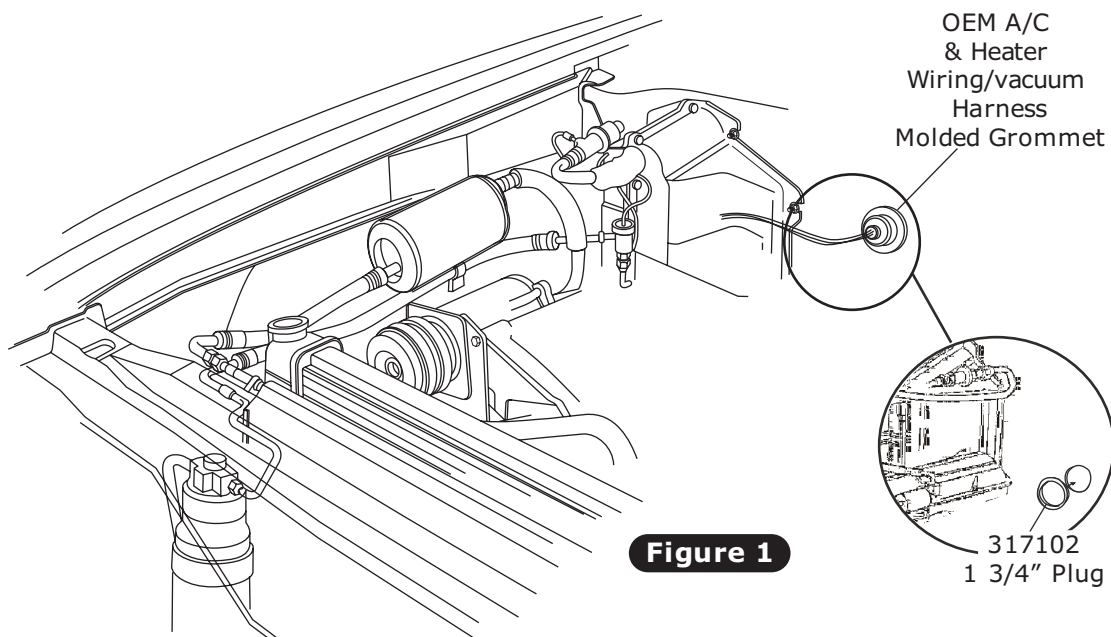

**Figure 1**

## Condenser Assembly & Installation

1. Refer to separate instructions included with the condenser kit to install the condenser.
2. Binary switch installation (Refer to condenser instructions).

## Compressor & Brackets

1. Refer to separate instructions included with the bracket kit to install the compressor bracket.

## Pulleys

1. In most instances, the belt lengths will remain the same.



## Passenger Compartment

### Remove the Following:

1. Remove glove box door (retain) and glove box (discard). (See Figure 2, below)
2. Disconnect all wire and cables from control panel and radio.
3. Remove radio and control panel (retain).
4. All hose and ducting from OEM louvers. (See Figure 2, below)
5. (2) OEM louvers in dash (retain). (See figure 2, below)
6. OEM defrost duct assembly by straightening 4 metal tabs. (See Figure 2, below)
7. OEM A/C & heater ASM (discard). (See Figure 2, below)
8. Passenger side kick panel/ fresh air door ASM as shown in Figure 2a.

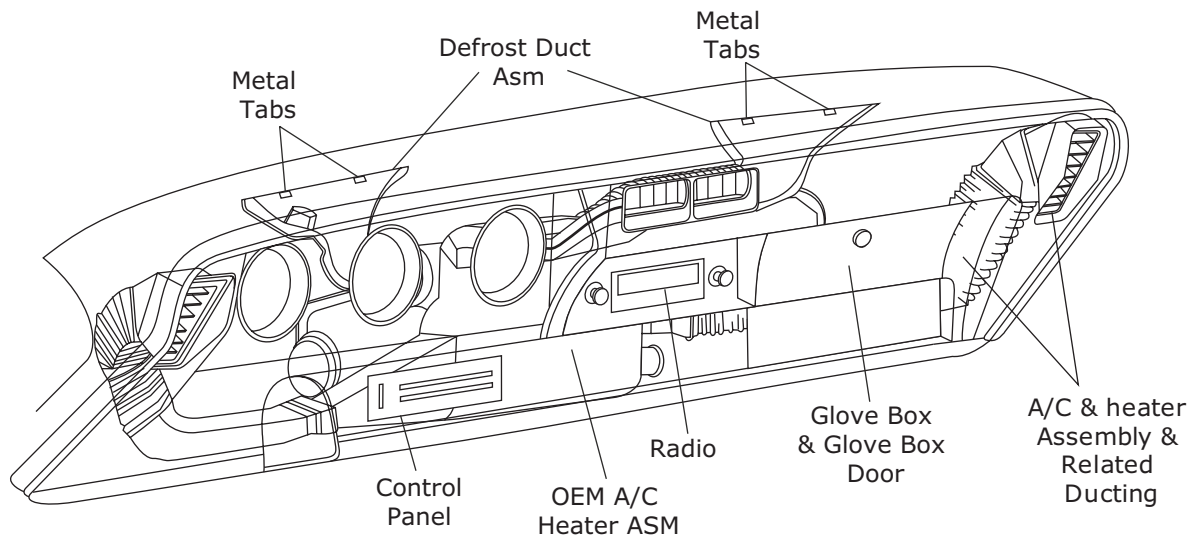

**Figure 2**

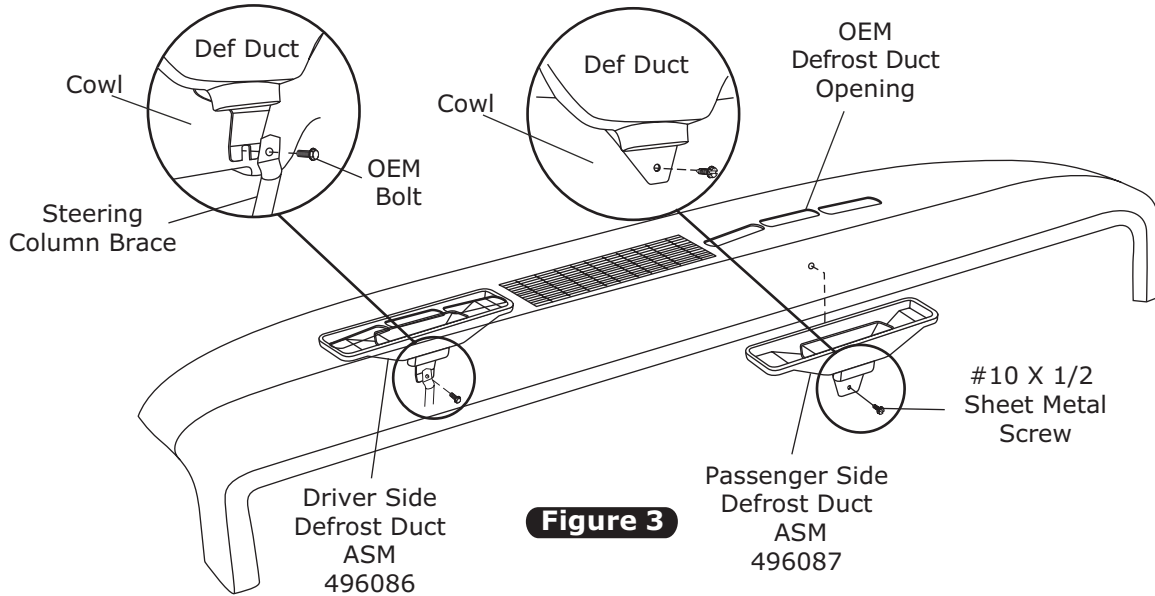

**Figure 2a**



## Defrost Duct Installation

1. Install defrost ducts under dash and align with oem opening. Install the passenger side defrost duct to cowl using #10 x 1/2" sheetmetal screws. See figure 3 below. **NOTE: driver side defrost duct installs behind steering column brace and secures using steering column oem bolt as shown below.**



**Figure 3**

## Hose Adapter Installation

1. Install S-clips on hose adapters as shown in Figure 4, below.
2. Install driver & passenger side hose adapter on OEM louvers. (See Figure 4, below)

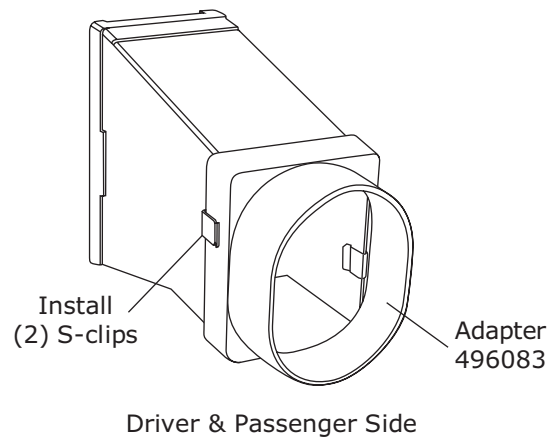

**Figure 4**





## Center Louver Installation (1968 Cutlass)

1. Cut & remove OEM center louver ASM as shown in Figure 5 below.
2. Install (4) S-clips on hose adapter. (See Figure 5a, below).
3. Install center louver hose adapter on center louver assembly as shown in Figure 5a, below.

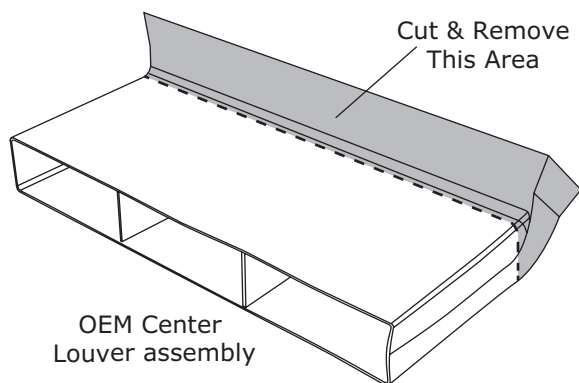

**Figure 5**

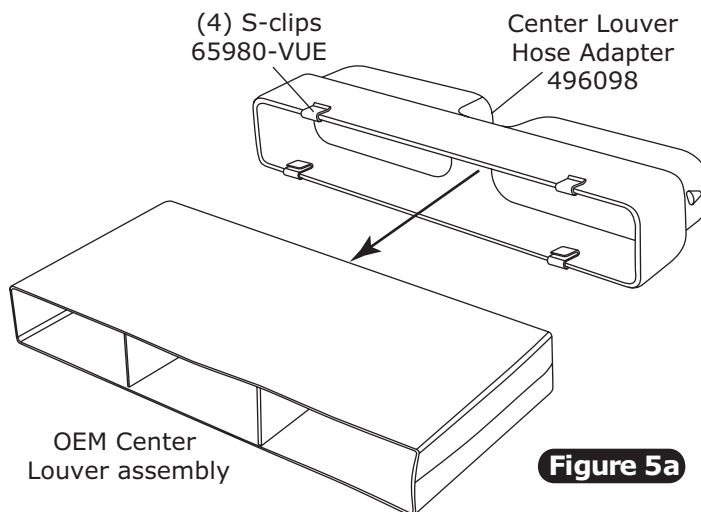

**Figure 5a**

## Center Louver Installation (1969 Cutlass)

1. Modify OEM center louver ASM as shown in Figure 6 below.
2. Install (4) S-clips on hose adapter. (See Figure 6a, below).
3. Install center louver hose adapter on center louver assembly as shown in Figure 6a, below.

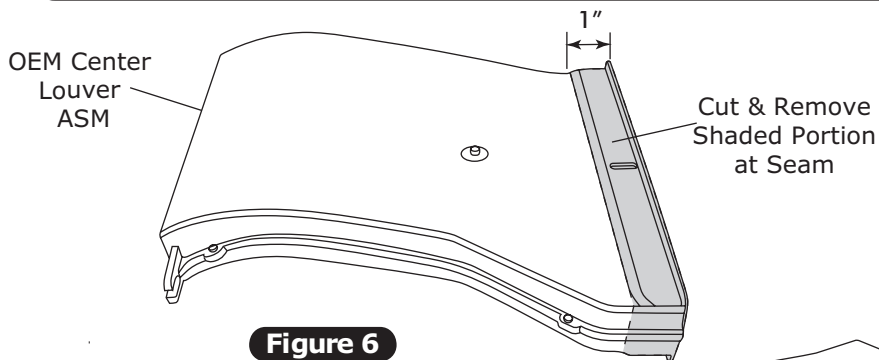

**Figure 6**

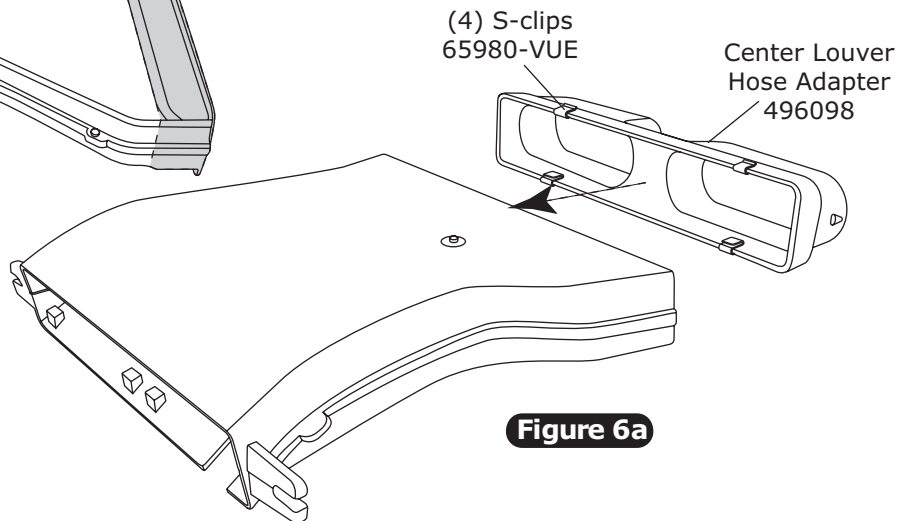

**Figure 6a**



## Fresh Air Cover Installation

1. Install (4) grommets in fresh air cap. (See Figure 7, below)
  2. Apply a 1/4" bead of silicone around the back side of the fresh air cap as shown in Figure 7, Below.
  3. Attach fresh air cap to firewall using a 1/4-20 x 1 1/2" bolt and washer. (See Figure 7, below)
- NOTE: Fresh air cap installs on engine side of firewall.**
4. Install 7/8" plug and 3/8" grommet in firewall. (See Figure 7, below)
  5. Install (2) 1/2" plugs as shown in Figure 7, below. (May need to enlarge to 1/2" dia.)
  6. Enlarge (2) OEM holes to 3/8" as shown in Figure 7, below.

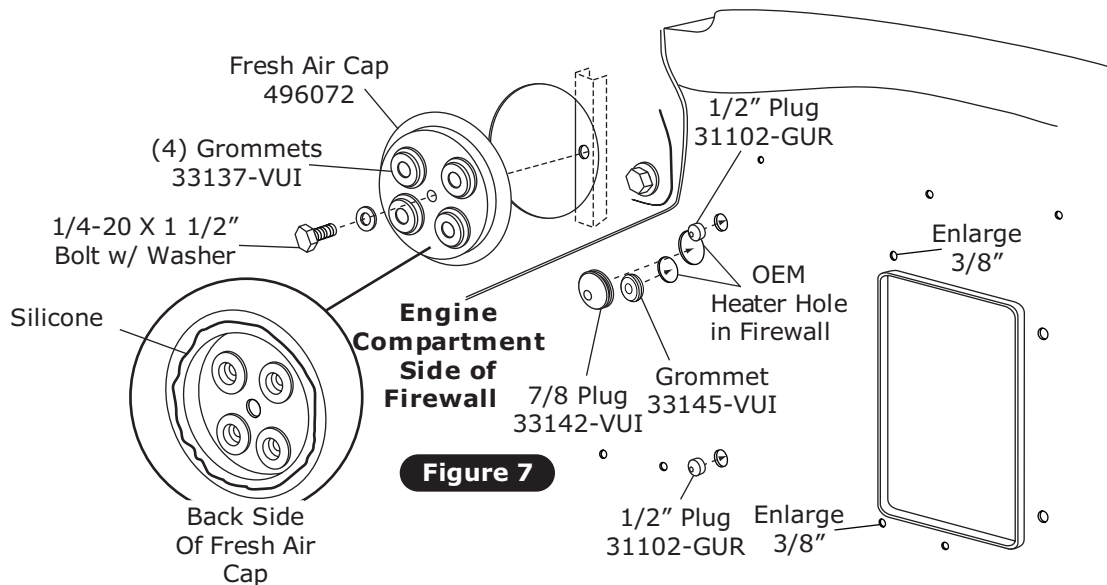

Figure 7

## Kick Panel Fresh Air Cap Installation

1. Install (4) grommets in kick panel fresh air cap. (See Figure 8a, below)
2. Route A/C and heater hose through fresh air cap and kick panel fresh air cap as shown in Figure 8 and 8b, below.
3. Apply a 1/4" bead of silicone around the back side of kick panel fresh air cap as shown in Figure 8a, below.
4. Secure kick panel fresh air cap using OEM screws, as shown in Figure 8b, below.

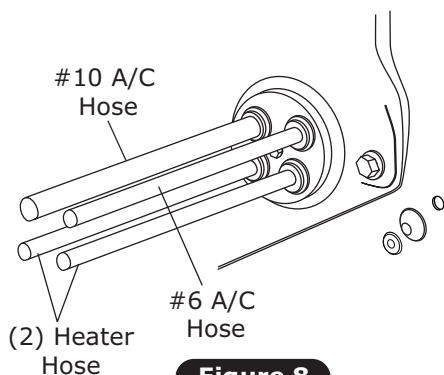

Figure 8

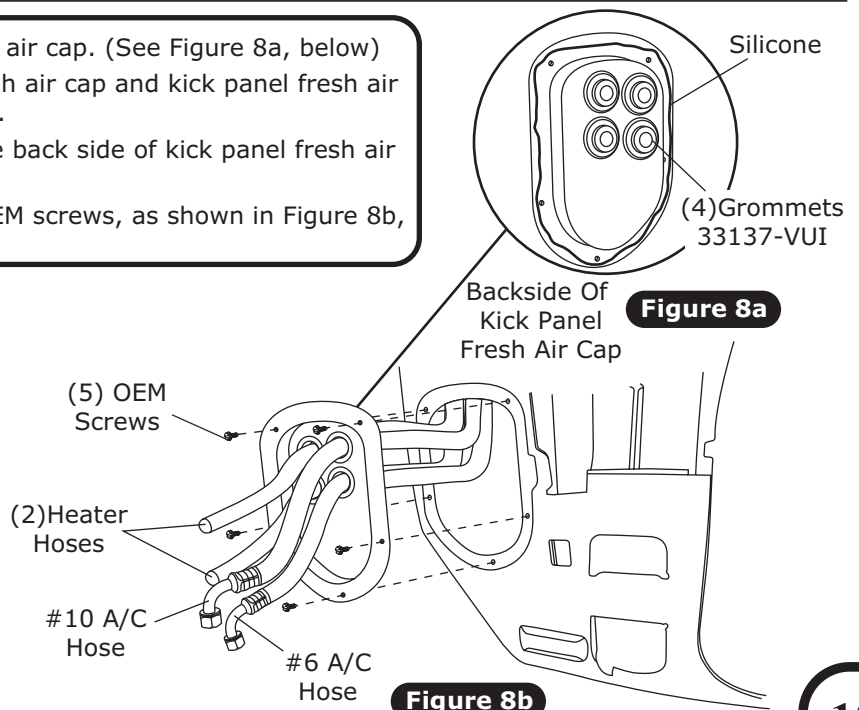

Figure 8a

Figure 8b



## Firewall Cover Installation

1. Apply a 1/4" bead of silicone around the back side of the firewall cover as shown in Figure 9, below.
2. From inside the car, install firewall cover on firewall. Secure to firewall from engine compartment using (2) 1/4-20 x 1" hex bolts, flat washers. (See Figure 9, below). **NOTE: Use seam sealer or silicone to fill gap between cover and lip in firewall before painting.**

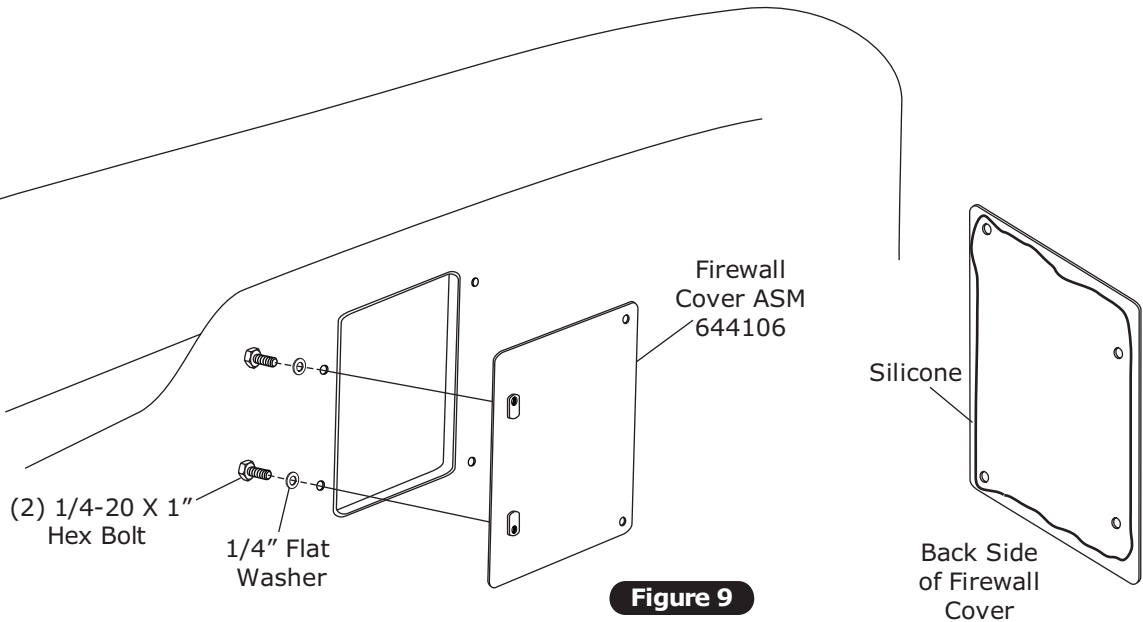

## Evaporator Installation

1. On a work bench install (2) heater fittings with properly lubricated O-rings. (See Figure 15, Page 14, and Figure 11, Page 12.)
2. Install evaporator front & rear mounting brackets on evaporator using (6) 1/4-20 x 1/2 hex bolts and tighten as shown in Figure 10 below & Figure 11, Page 12.
3. Lay evaporator subcase on passenger side floor board. Install A/C & heater hose on evaporator as shown in Figure 15, Page 14 and Figure 12, Page 13. **NOTE: Wrap the #10 fitting connections with press tape.** See Figure 12, Page 13.)

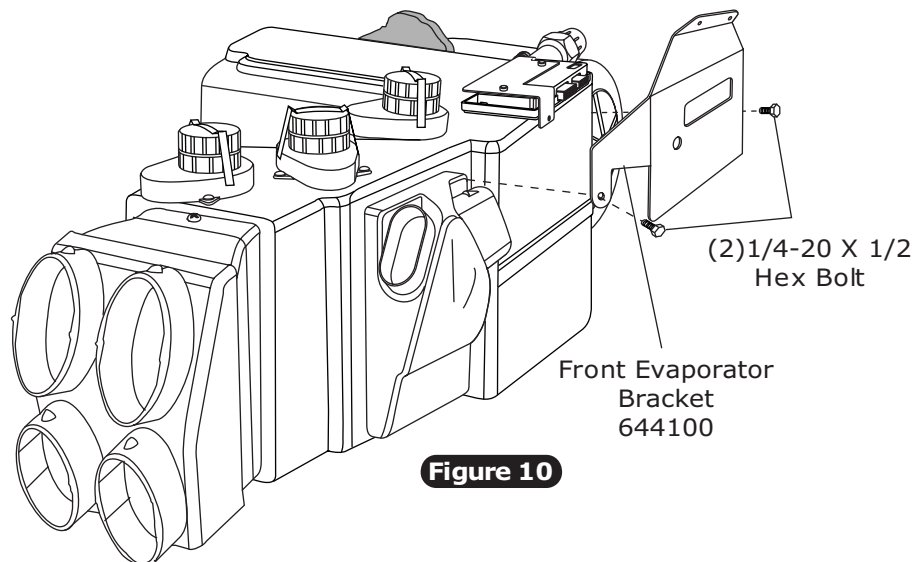



## Bracket Installation Cont.

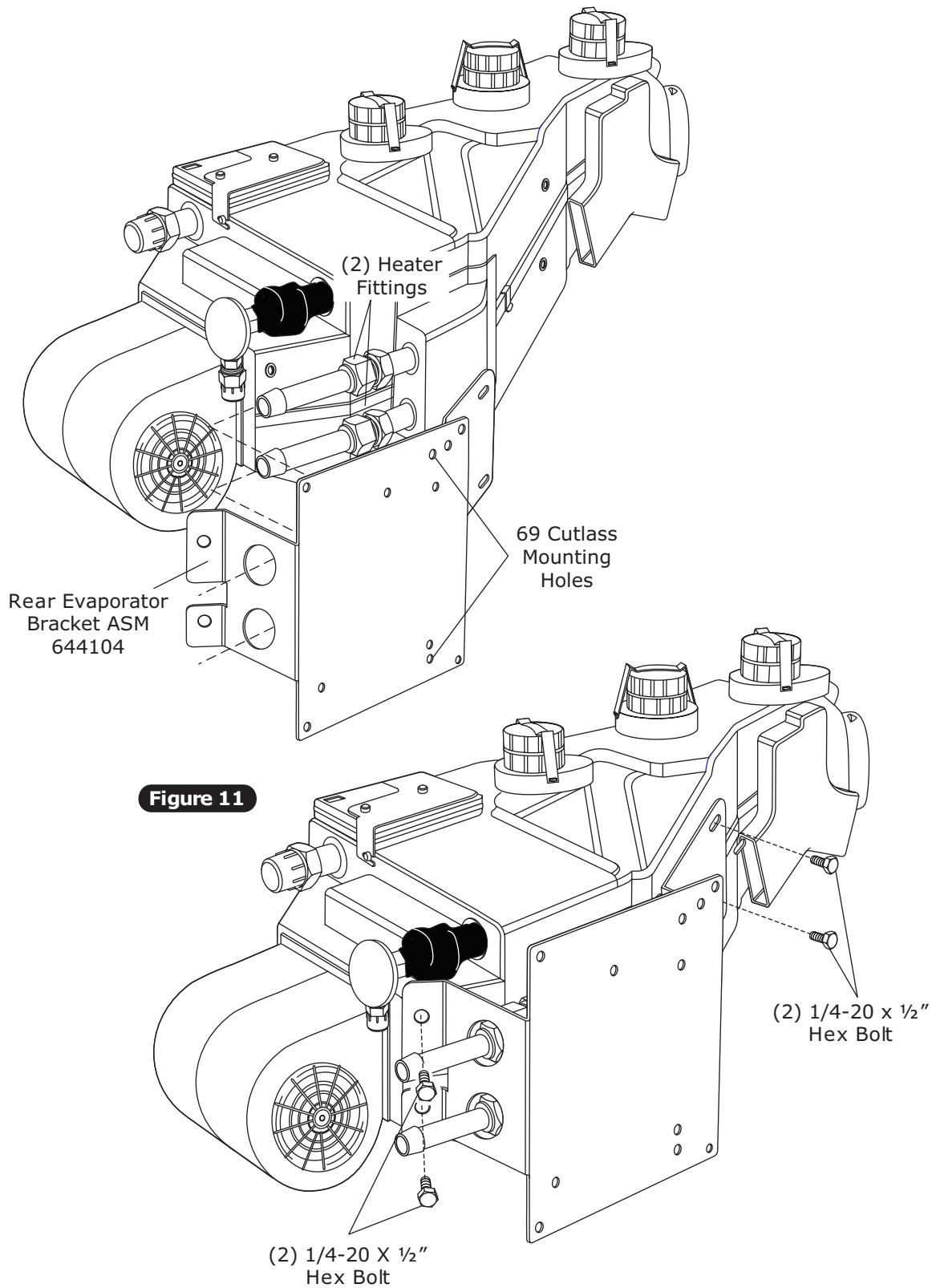
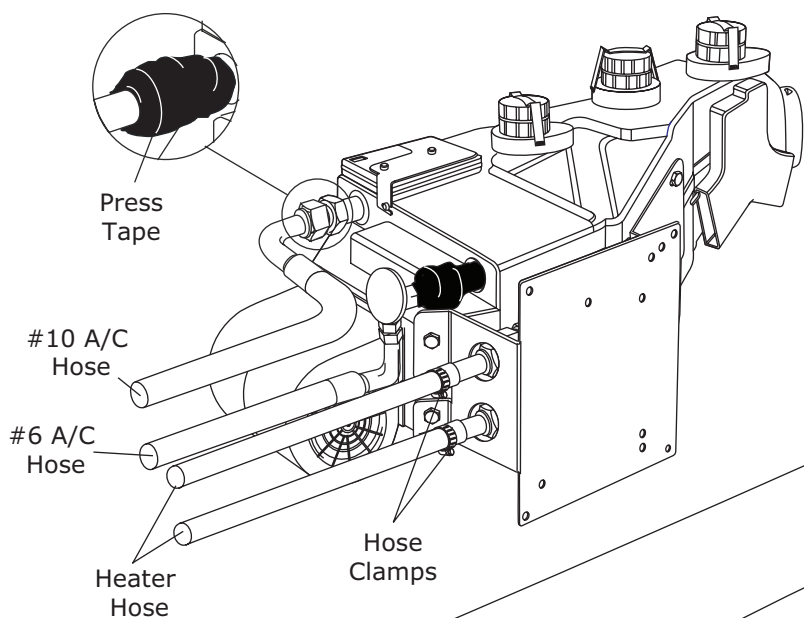

Figure 11



## Evaporator Installation Cont.

1. Lift evaporator unit up under the dashboard. Secure loosely to the firewall from the engine compartment side using (2) 1/4-20 x 1 1/4 hex bolt and flat washer. (See Figure 13, below).
2. Verify that evaporator unit is level and square to the dash.
3. Secure the front evaporator mounting bracket to cowl. Using bracket as template drill (2) 3/16" holes in cowl. Secure with (2) #14 x 3/4 hex sheet metal screws see Figure 13, below.
4. Then tighten all mounting bolts. **NOTE: Tighten the bolt on firewall first, then the front mounting bracket.**



**Figure 12**

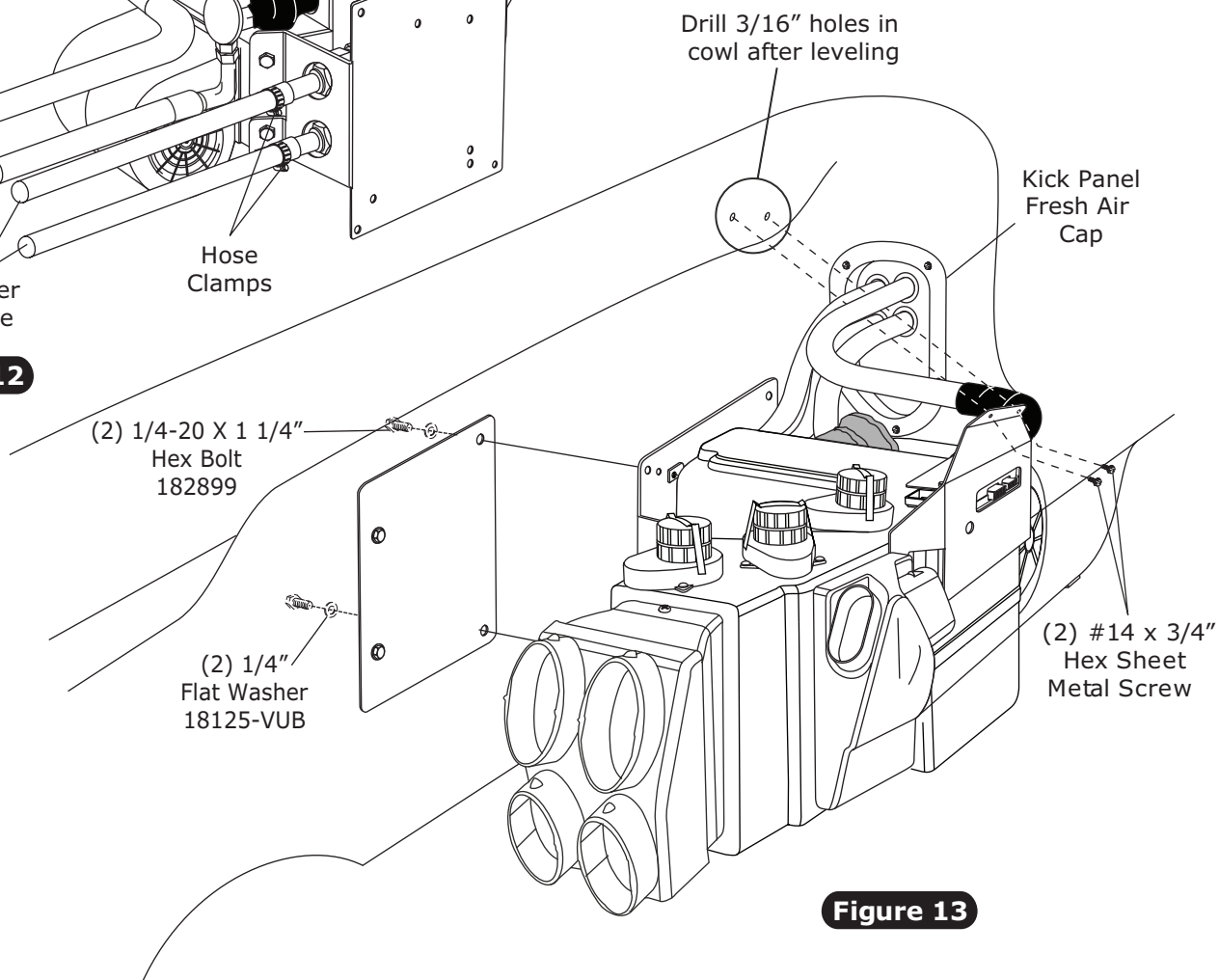
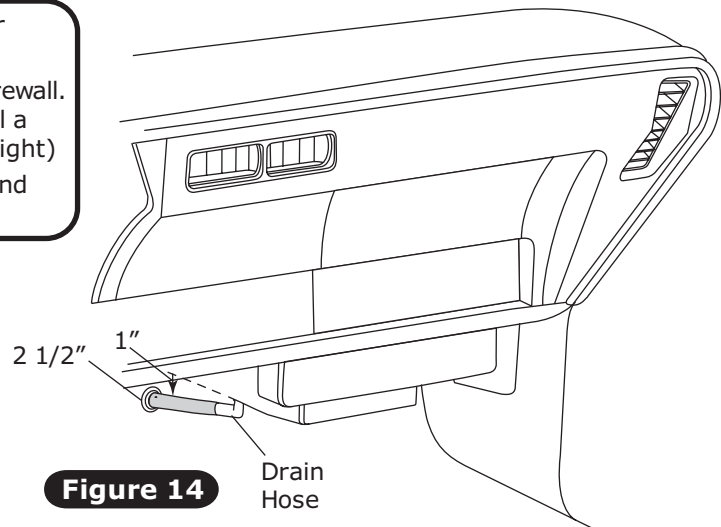
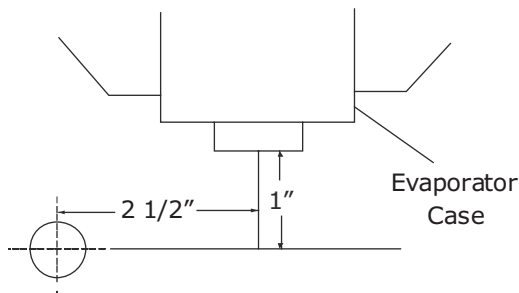

**Figure 13**



## Drain Hose Installation

1. Locate evaporator drain on bottom of evaporator case.
2. In line with drain, lightly make a mark on the firewall. Measure 1" down and 2 1/2" to the left, and drill a 5/8" hole through the firewall. (See Figure 14, right)
3. Install drain hose to bottom of evaporator unit and route through firewall. (See Figure 14, right)



**Figure 14**

## Lubricating O-rings

**For a proper seal of fittings: Install supplied O-rings as shown, and lubricate with supplied oil.**

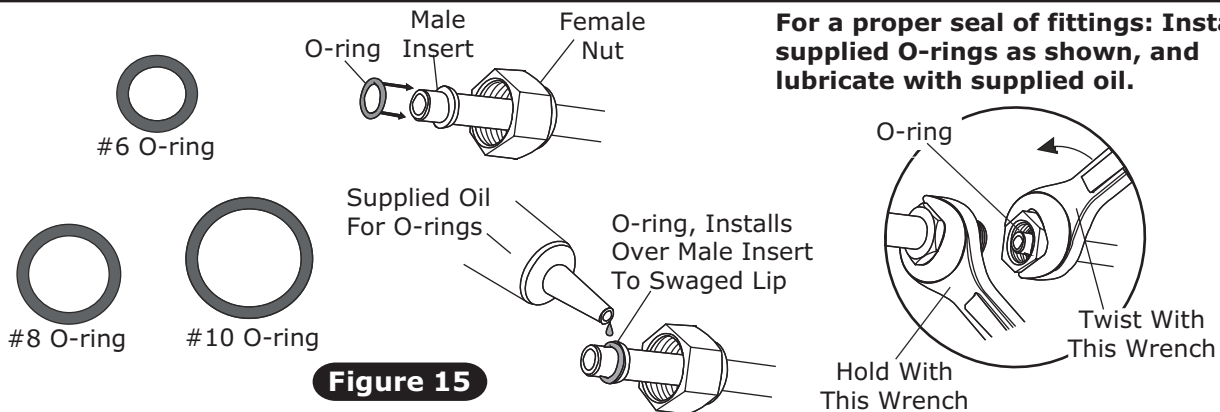

**Figure 15**

## A/C Hose Installation

### Standard Hose Kit:

1. Locate the #8 compressor A/C hose. Lubricate (2) #8 O-rings (See Figure 15, above) and connect the 90° female fitting w/ 134a service port to the #8 discharge port on the compressor. Route the 90° female fitting to the #8 condenser hardline coming through core support. (See Figure 16, Page 15) Tighten each fitting connection as shown in Figure 15 above.
2. Locate the #10 compressor A/C hose. Lubricate (2) #10 O-rings (see figure 15, above) and connect the #10 135° female fitting w/134a service port to the #10 suction port on the compressor. Route the 90° female fitting to the #10 evaporator. (See Figure 12 Page 13 and Figure 16, Page 15). Tighten each fitting connection as shown in Figure 15 above.
3. Locate the #6 evaporator A/C hose. Lubricate (2) #6 O-rings (see figure 15, above) and connect the 90° female fitting to the #6 hardline coming through the core support from drier. Route the 90° female fitting to the #6 evaporator. (See Figure 12, Page 13 and Figure 16 Page 15). Tighten each fitting connection as shown in Figure 15, above.

### Modified A/C Hose Kit:

1. Refer to separate instructions included with modified hose kit.



## Heater Hose & Heater Control Valve Installation

1. Route a piece of heater hose from the water pump to the top heater fitting of heater core as shown in Figure 12, Page 13, and Figure 16, below. Secure using hose clamps. **NOTE: OEM water pump outlet is 3/4". A 3/4" x 5/8" reducer fitting is required (not supplied).**
2. Route a piece of heater hose from the intake to the bottom heater fitting of heater core as shown in Figure 12, Page 13, and Figure 16, below. Install heater control valve in line with intake manifold (pressure side) heater hose, and secure using hose clamps as shown in Figure 16, below. **NOTE: Proper flow direction.**

## A/C & Heater Hose Routing

**NOTE: OEM Water Pump Outlet Is 3/4". A 3/4" x 5/8" Reducer Fitting Is Required (Not Supplied).**

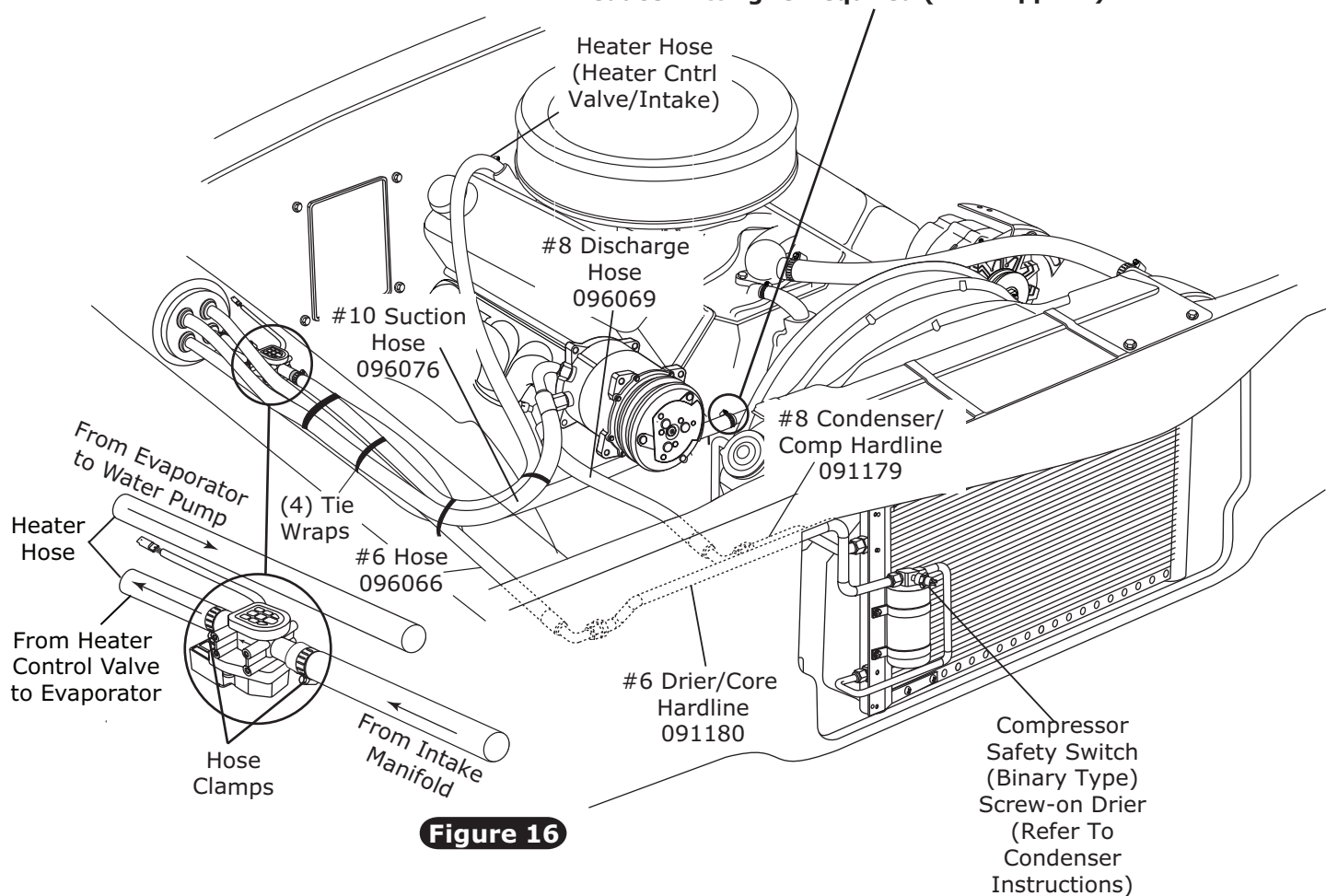



## Final Steps

1. Install duct hoses as shown in Figure 20 & 21, Page 17.
2. Install 3/8" grommet (See Figure 17, below).
3. Route A/C wires through 3/8 grommet as shown on Figure 17, below (12 volt/ground/binary switch/heater valve).
4. Install control panel assembly.
5. Plug the wiring harnesses into the ECU module on sub case as shown in Figure 21, Page 17 (Wire according to wiring diagram on Pages 18 and 19.)
6. Install glove box in glove box compartment using OEM screws (See Figure 18, below).
7. Modify passenger side kick panel as shown in Figure 19, below.
8. Reinstall all previously removed items (battery, inner fender and radiator).
9. Fill radiator with at least a 50/50 mixture of approved antifreeze and distilled water. It is the owner's responsibility to keep the freeze protection at the proper level for the climate in which the vehicle is operated. Failure to follow antifreeze recommendations will cause heater core to corrode prematurely and possibly burst in A/C mode and/or freezing weather, voiding your warranty.
10. Double check all fittings, brackets and belts for tightness.
11. Vintage Air recommends that all A/C systems be serviced by a certified automotive air conditioning technician.
12. Evacuate the system for a minimum of 45 minutes prior to charging, and leak check prior to servicing.
13. Charge the system to the capacities stated on the information page (Page 4) of this instruction manual.
14. See Operation of Controls procedures on Page 20.

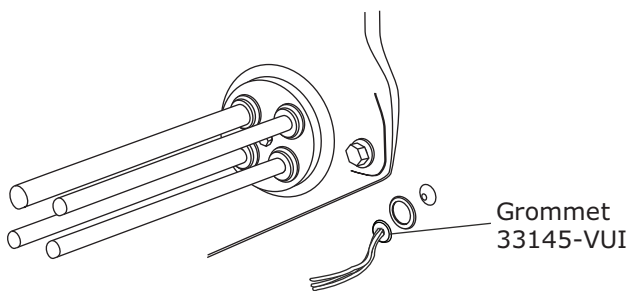

**Figure 17**

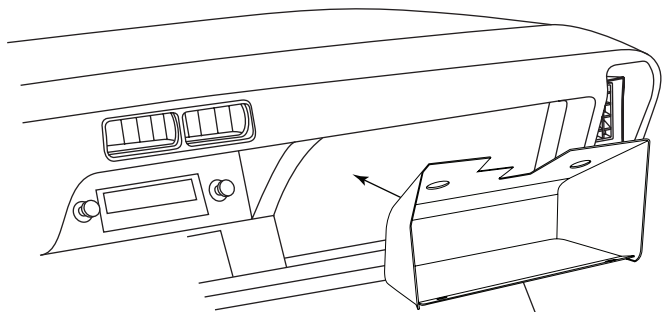

**Figure 18**

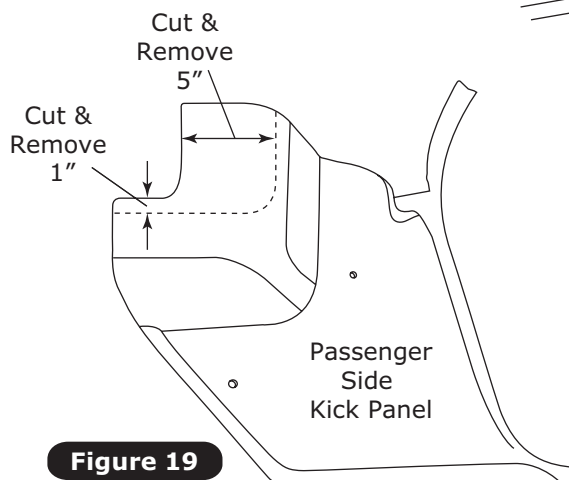

**Figure 19**





## Control Panel & Duct Hose Routing

1. Route passenger side duct hose as shown below.
2. Tie wrap duct hose to dash brace for glove box arm clearance.

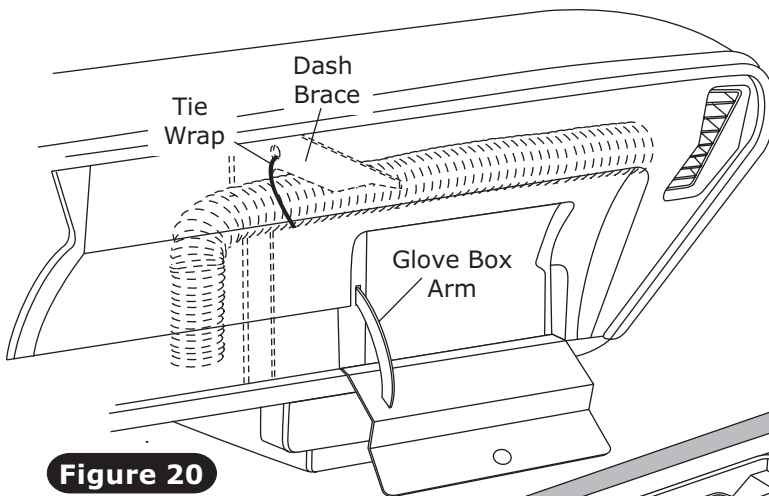

**Figure 20**

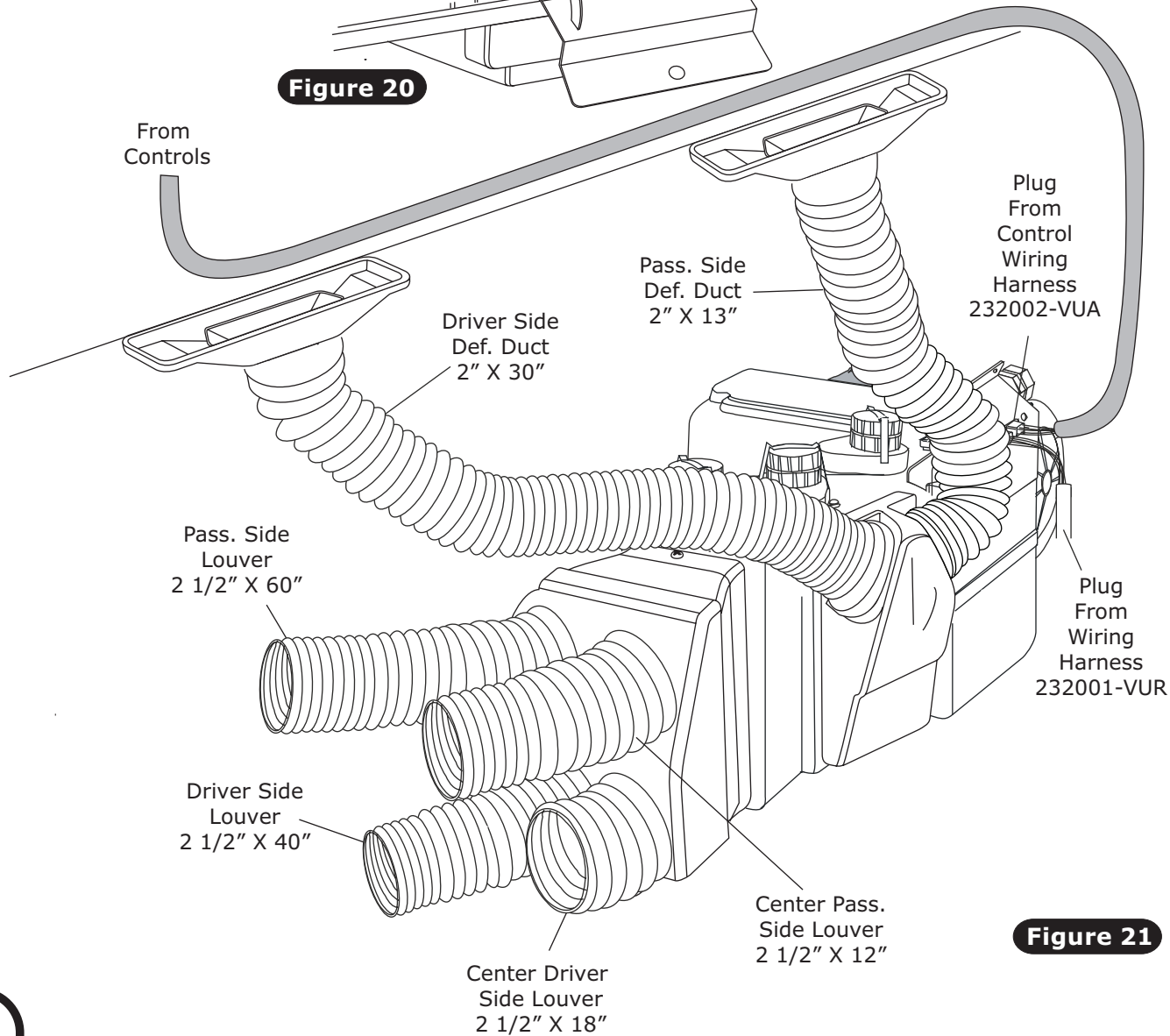
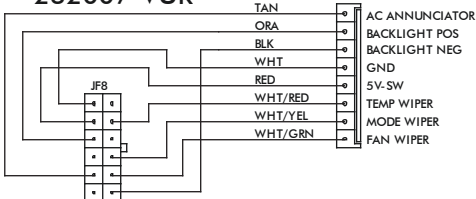

**Figure 21**



# Wiring Diagram

## 232007-VUR



VIEWED FROM WIRE SIDE

## 232002-VUA

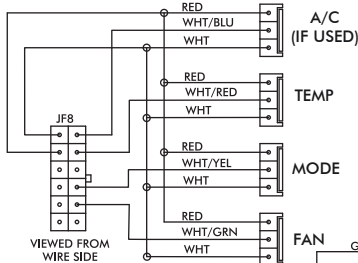

VIEWED FROM WIRE SIDE

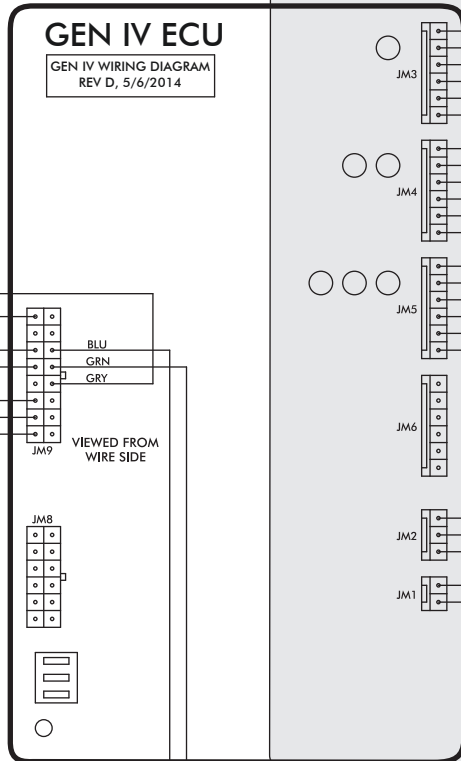

## PRE-WIRED

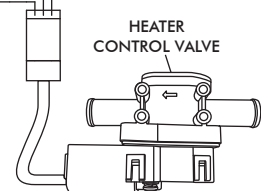
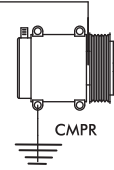
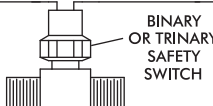
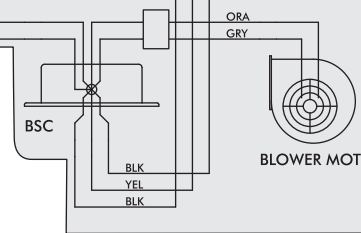
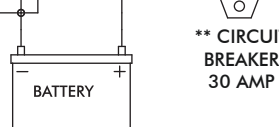
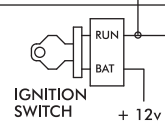
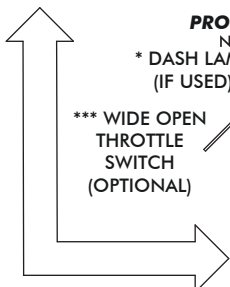
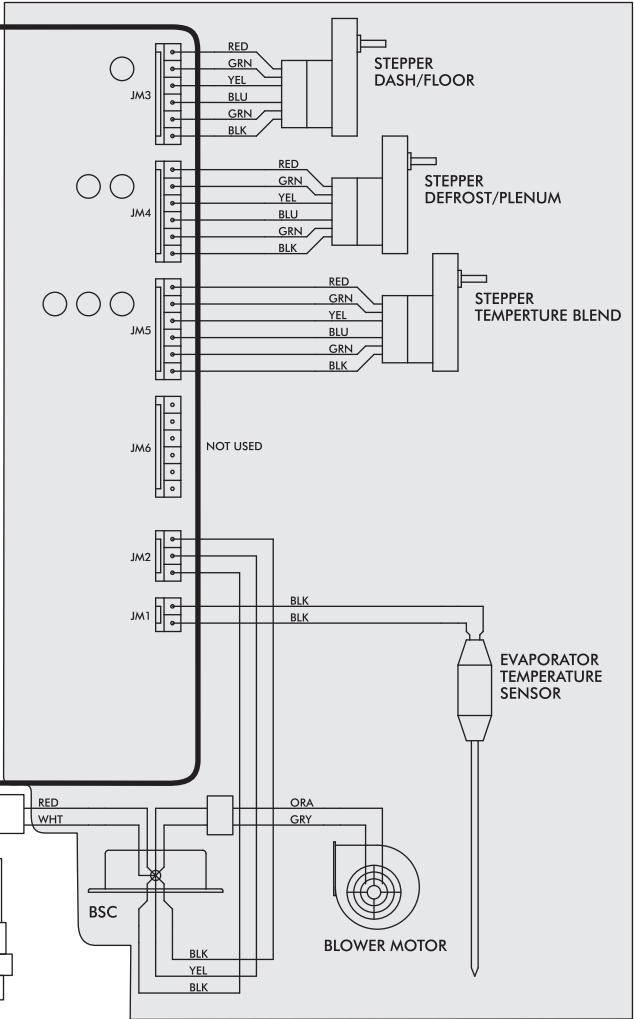

NOTE: = CHASSIS GROUND

- Dash Lamp Is Used Only With Type 232007-VUR Harness.
- Warning: Always Mount Circuit Breaker As Close to the Battery As Possible. (NOTE: Wire Between Battery and Circuit Breaker Is Unprotected and Should Be Carefully Routed to Avoid a Short Circuit).
- Wide Open Throttle Switch Contacts Close Only at Full Throttle, Which Disables A/C Compressor.



# Gen IV Wiring Connection Instruction

WIRING HARNESS

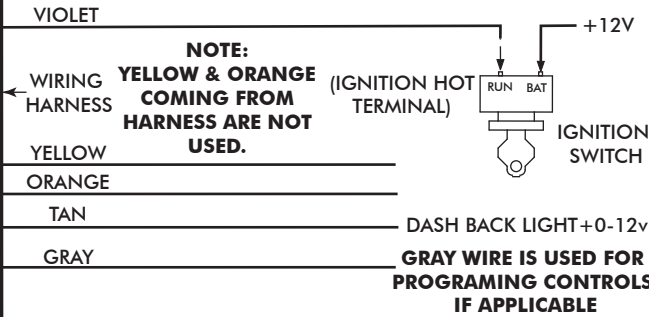
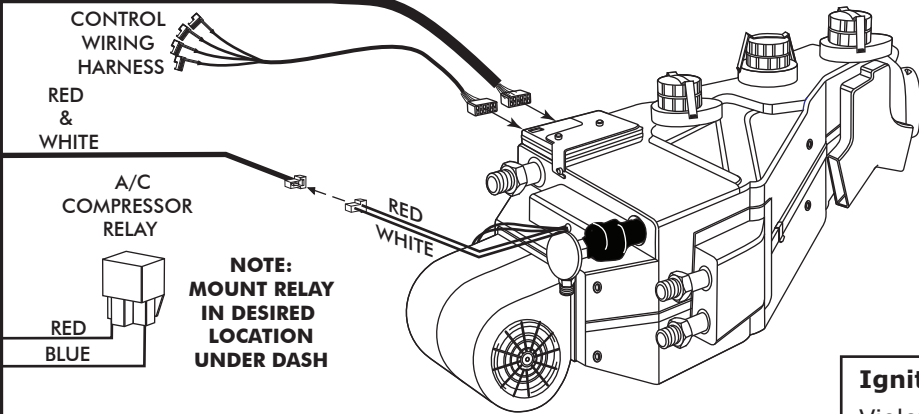

**Ignition Switch:**  
Violet 12V Ign Switch Source (Key On Accessory) Position Must Be Switched.

**Dash Light:**  
Tan Wire Used Only With Vintage Air Supplied Control Panel With LED Back Light.

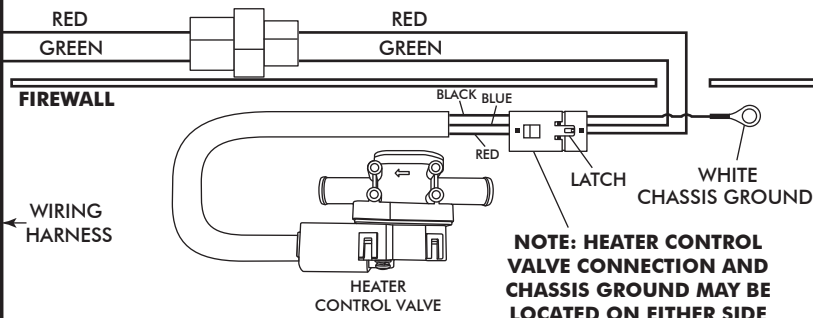

**Heater Control Valve:**  
Install With Servo Motor Facing Down, As Shown. Note Flow Direction Arrow Molded Into Valve Body, And Install Accordingly.

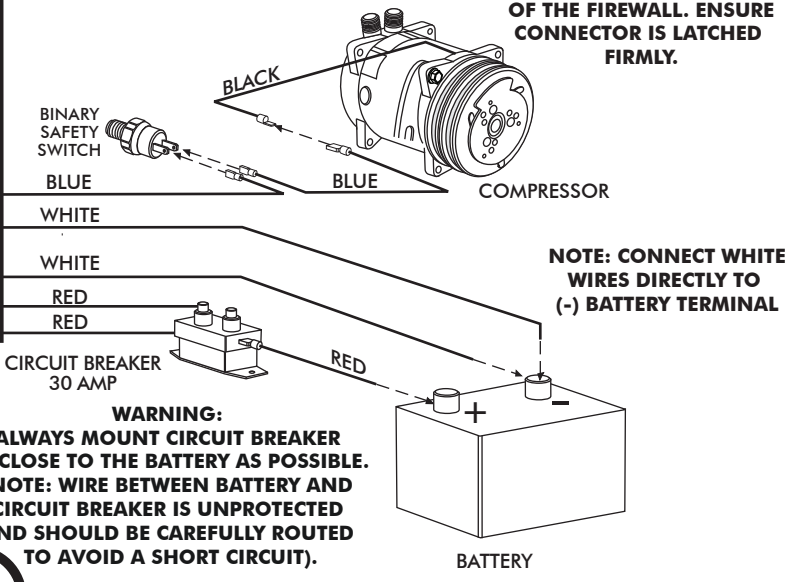

**Binary/Trinary & Compressor:**  
Binary: Connect As Shown (Typical Compressor Wiring). Be Sure Compressor Body Is Grounded.  
Trinary Switch: Connect According To Trinary Switch Wiring Diagram.

**Circuit Breaker/Battery:**  
White **Must** Run To (-) Battery. Red May Run To (+) Battery Or Starter. Mount Circuit Breaker As Close to Battery As Possible.



## Operation Of Controls

On Gen IV systems with three lever/knob controls, the temperature control toggles between economy/heat and A/C modes. To activate A/C, move the temperature lever all the way to COLD and then back it off to the desired vent temperature. For economy/heat mode, move the temperature lever all the way to HOT and then adjust to the desired vent temperature. Each time you toggle between modes, the blower will momentarily change speed to indicate the change.

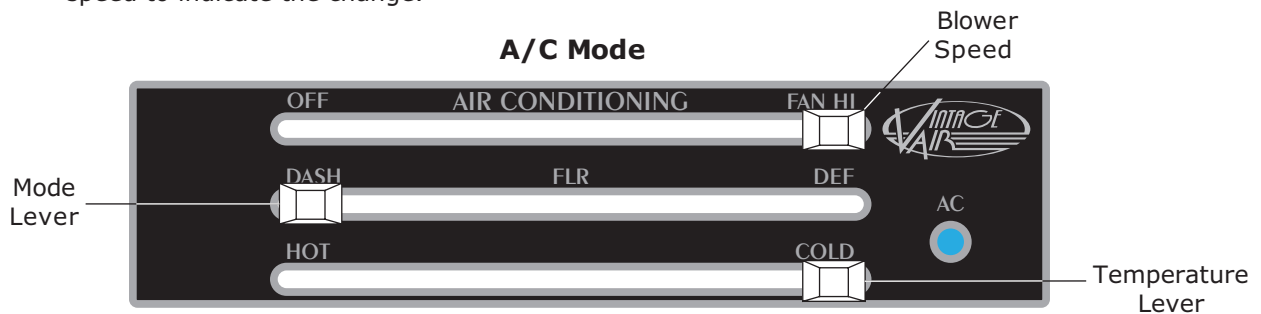

**Blower Speed**  
Adjust to desired speed.

**Mode Lever**  
Slide the lever all the way left for DASH mode.

**Temperature Lever**  
In A/C mode, slide the temperature lever all the way right to engage compressor (Slide lever left or right to adjust to desired temperature).

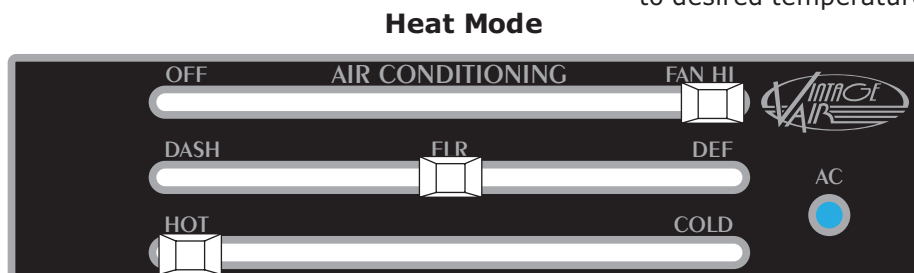

**Blower Speed**  
Adjust to desired speed.

**Mode Lever**  
Slide the lever to the center position for FLR mode.

**Temperature Lever**  
Slide the temperature lever all the way left to the hot position (Slide lever left or right to desired temperature).

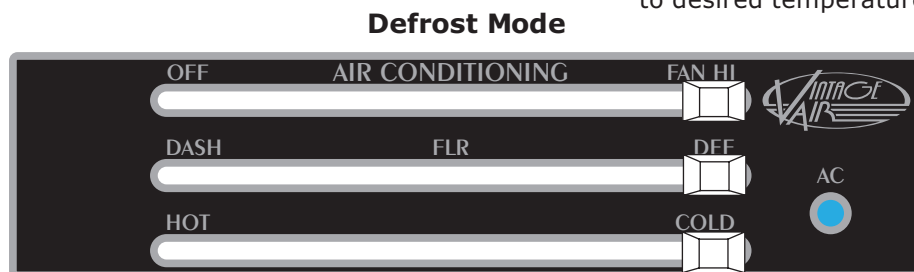

**Blower Speed**  
Adjust to desired speed.

**Mode Lever**  
Slide the lever all the way right for DEF mode.

**Temperature Lever**  
Adjust lever to desired temperature (Compressor is automatically engaged).



# Troubleshooting Guide

Symptom	Condition	Checks	Actions	Notes
1a. Blower stays on high speed when ignition is on.	No other functions work.	<p>Check for damaged pins or wires in control head plug.</p> <p>Check for damaged ground wire (white) in control head harness.</p> <p>Check for damaged blower switch or potentiometer and associated wiring.</p>	<p>Verify that all pins are inserted into plug. Ensure that no pins are bent or damaged in ECU.</p> <p>Verify continuity to chassis ground with white control head wire at various points.</p>	<p>Loss of ground on this wire renders control head inoperable.</p> <p>See blower switch check procedure.</p>
	All other functions work.			
1b. Blower stays on high speed when ignition is on or off.		<p>Unplug 3-wire BSC control connector from ECU. If blower shuts off, ECU is either improperly wired or damaged.</p> <p>Unplug 3-wire BSC control connector from ECU. If blower stays running, BSC is either improperly wired or damaged.</p>	<p>Be sure the small, 20 GA white ground wire is connected to the battery ground post. If it is, replace the ECU.</p> <p>Check to ensure that no BSC wiring is damaged or shorted to vehicle ground. The BSC operates the blower by ground side pulse width modulation switching. The positive wire to the blower will always be hot. If the "ground" side of the blower is shorted to chassis ground, the blower will run on HI.</p> <p>Replace BSC (This will require removal of evaporator from vehicle).</p>	<p>No other part replacements should be necessary.</p>
2. Compressor will not turn on (All other functions work).	System is not charged.	<p>System must be charged for compressor to engage.</p> <p>Check for faulty A/C potentiometer or associated wiring (Not applicable to 3-pot controls).</p> <p>Check for disconnected or faulty thermistor.</p>	<p>Charge system or bypass pressure switch.</p> <p>Check continuity to ground on white control head wire. Check for 5V on red control head wire.</p> <p>Check 2-pin connector at ECU housing.</p>	<p><b>Danger: Never bypass safety switch with engine running. Serious injury can result.</b></p> <p>To check for proper pot function, check voltage at white/blue wire. Voltage should be between 0V and 5V, and will vary with pot lever position.</p> <p>Disconnected or faulty thermistor will cause compressor to be disabled.</p>
	System is charged.			
3. Compressor will not turn off (All other functions work).		<p>Check for faulty A/C potentiometer or associated wiring.</p> <p>Check for faulty A/C relay.</p>	<p>Repair or replace pot/control wiring.</p> <p>Replace relay.</p>	<p>Red wire at A/C pot should have approximately 5V with ignition on. White wire will have continuity to chassis ground. White/Blue wire should vary between 0V and 5V when lever is moved up or down.</p>



# Troubleshooting Guide (Cont.)

Symptom	Condition	Checks	Actions	Notes
4. System will not turn on, or runs intermittently.	Works when engine is not running; shuts off when engine is started (Typically early Gen IV, but possible on all versions).	Noise interference from either ignition or alternator.	Install capacitors on ignition coil and alternator. Ensure good ground at all points. Relocate coil and associated wiring away from ECU and ECU wiring. Check for burned or loose plug wires.	Ignition noise (radiated or conducted) will cause the system to shut down due to high voltage spikes. If this is suspected, check with a quality oscilloscope. Spikes greater than 16V will shut down the ECU. Install a radio capacitor at the positive post of the ignition coil (See radio capacitor installation bulletin). A faulty alternator or worn out battery can also result in this condition.
	Will not turn on under any conditions.	Verify connections on power lead, ignition lead, and both white ground wires.	Check for positive power at heater valve green wire and blower red wire. Check for ground on control head white wire.	
		Verify battery voltage is greater than 10 volts and less than 16.	Verify proper meter function by checking the condition of a known good battery.	
5. Loss of mode door function.	No mode change at all.	Check for damaged mode switch or potentiometer and associated wiring.		Typically caused by evaporator housing installed in a bind in the vehicle. Be sure all mounting locations line up and don't have to be forced into position.
	Partial function of mode doors.	Check for obstructed or binding mode doors. Check for damaged stepper motor or wiring.		
6. Blower turns on and off rapidly.	Battery voltage is at least 12V.	Check for at least 12V at circuit breaker.	Ensure all system grounds and power connections are clean and tight.	System shuts off blower at 10V. Poor connections or weak battery can cause shutdown at up to 11V.
	Battery voltage is less than 12V.	Check for faulty battery or alternator.	Charge battery.	
7. Erratic functions of blower, mode, temp, etc.		Check for damaged switch or pot and associated wiring.	Repair or replace.	
	When ignition is turned on, blower momentarily comes on, then shuts off. This occurs with the blower switch in the OFF position.	This is an indicator that the system has been reset. Be sure the red power wire is on the battery post, and not on a switched source. Also, if the system is pulled below 7V for even a split second, the system will reset.	Run red power wire directly to battery.	





## Packing List Evaporator Kit (564069)

No.	QTY.	PART No.	DESCRIPTION
1.	1	744004-VUE	Gen IV 4-Vent Evap. Sub Case w/ 204 ECU
2.	1	784070	1968-69 Cutlass with A/C Acc. Kit

Check By: \_\_\_\_\_  
 Packed By: \_\_\_\_\_  
 Date: \_\_\_\_\_

①

**Gen IV 4-Vent  
Evap Sub Case  
w/204 ECU  
744004-VUE**

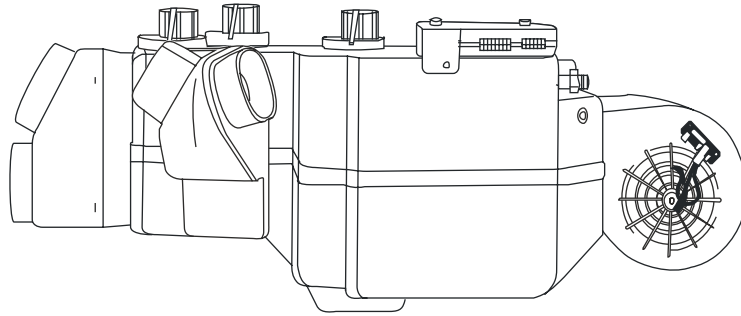

②

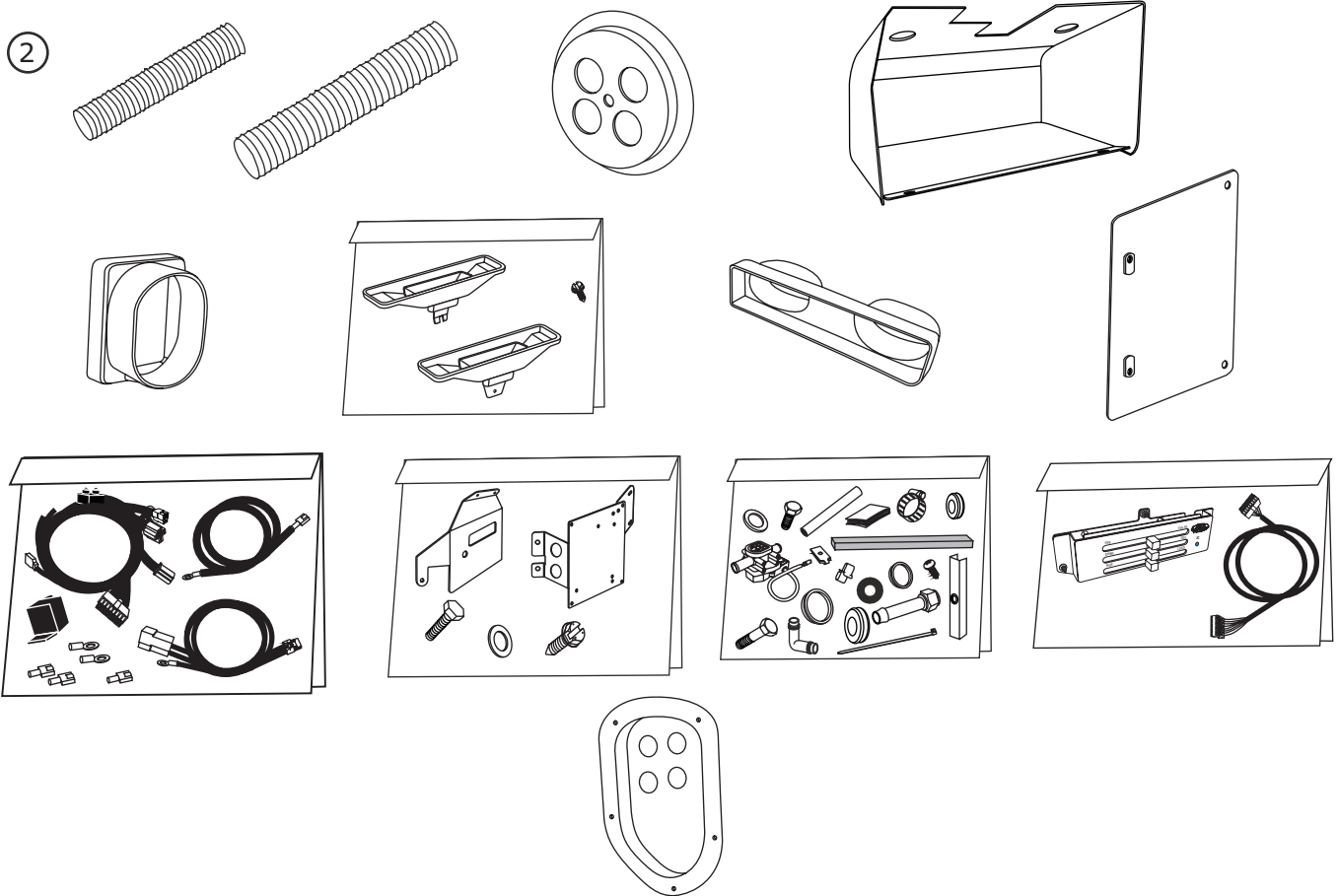

**Accessory Kit  
784070**

**NOTE: Images may not depict actual parts and quantities.  
Refer to packing list for actual parts and quantities.**