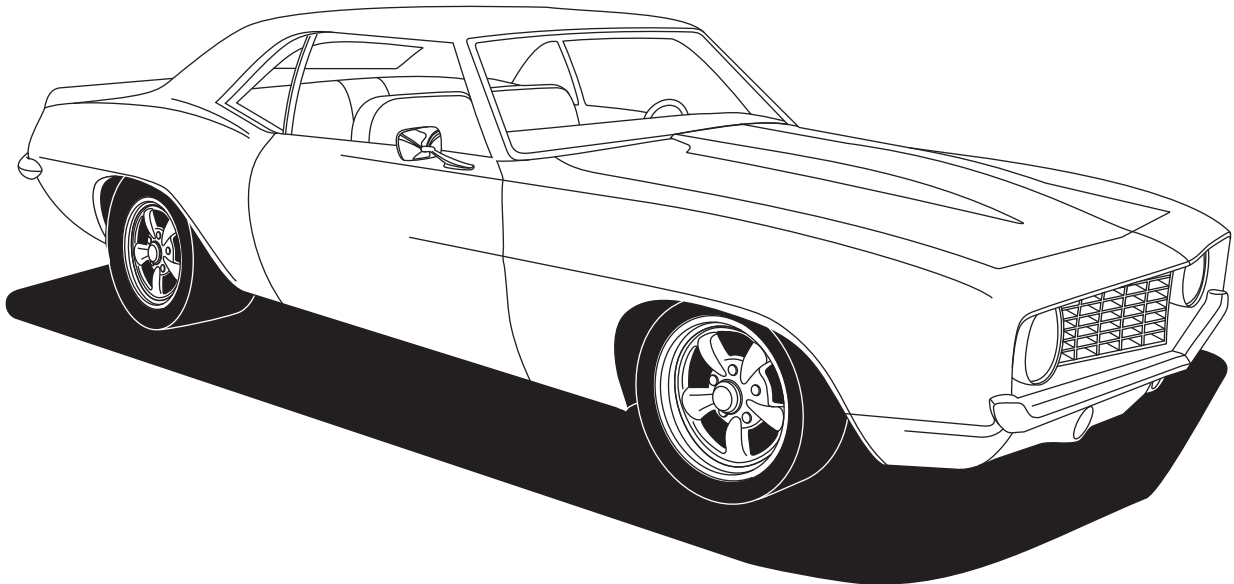




an ISO 9001:2015 Registered Company

# 1969 Chevrolet Camaro

*without* Factory Air  
Evaporator Kit  
(561191)



18865 Goll St. San Antonio, TX 78266  
Phone: 800-862-6658  
Sales: [sales@vintageair.com](mailto:sales@vintageair.com)  
Tech Support: [tech@vintageair.com](mailto:tech@vintageair.com)  
[www.vintageair.com](http://www.vintageair.com)



www.vintageair.com

# Table of Contents

Cover..... 1

Table of Contents..... 2

Packing List/Parts Disclaimer..... 3

Information Page, Wiring Notice..... 4-5

Engine Compartment Disassembly, Condenser Assembly and Installation, Compressor and Brackets..... 6

Dash Modification..... 7

Passenger Compartment Disassembly..... 8

Firewall Modification, Defrost Duct & Fresh Air Cover Installation..... 9

Hose Adapter Installation, Early Model Kick Panel Modification..... 10

Late Model Kick Panel Modification..... 11

Firewall Cover Insulation, Lubricating O-rings..... 12

Evaporator Bracket & Heater Hardline Installation..... 13

Fresh Air Cap & Kick Panel Cover Preparation, Heater and A/C Hose Installation..... 14-15

Wiring Installation, Kick Panel Installation..... 16-17

Evaporator Installation, Drain Hose Installation..... 18-19

Firewall Cover Installation..... 20

ECU Wiring Harness Installation..... 21

Duct Hose Installation..... 22

Fresh Air Cap Installation, A/C Hose Installation..... 23

Heater Control Valve Installation..... 24

Wiring Final Steps..... 25

Center Louver Installation, Glove Box Installation..... 26

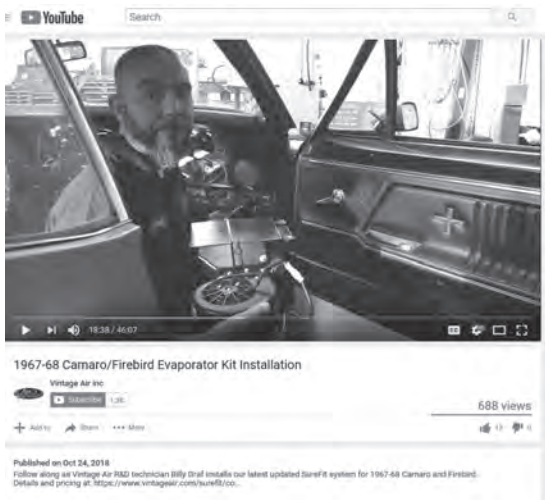
Final Steps, Wiring Diagram..... 27-28

Gen IV Wiring Connection Instruction..... 29

Operation of Controls..... 30

Troubleshooting Guide..... 31-32

Packing List..... 33



**A detailed tech video outlining the installation process is available on Vintage Air’s YouTube channel at <http://bit.ly/2GWAxWY>.**

**Viewing the tech video along with the written instructions will provide the installer the most detailed installation procedure.**



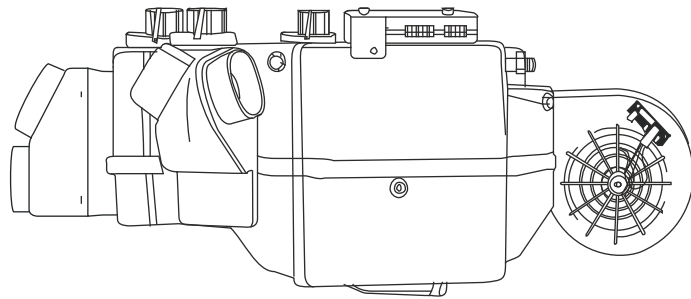
www.vintageair.com

## Packing List: Evaporator Kit (561191)

No.	Qty.	Part No.	Description
1.	1	744004-VUE	Gen IV Evaporator Sub Case
2.	1	781191	Accessory Kit

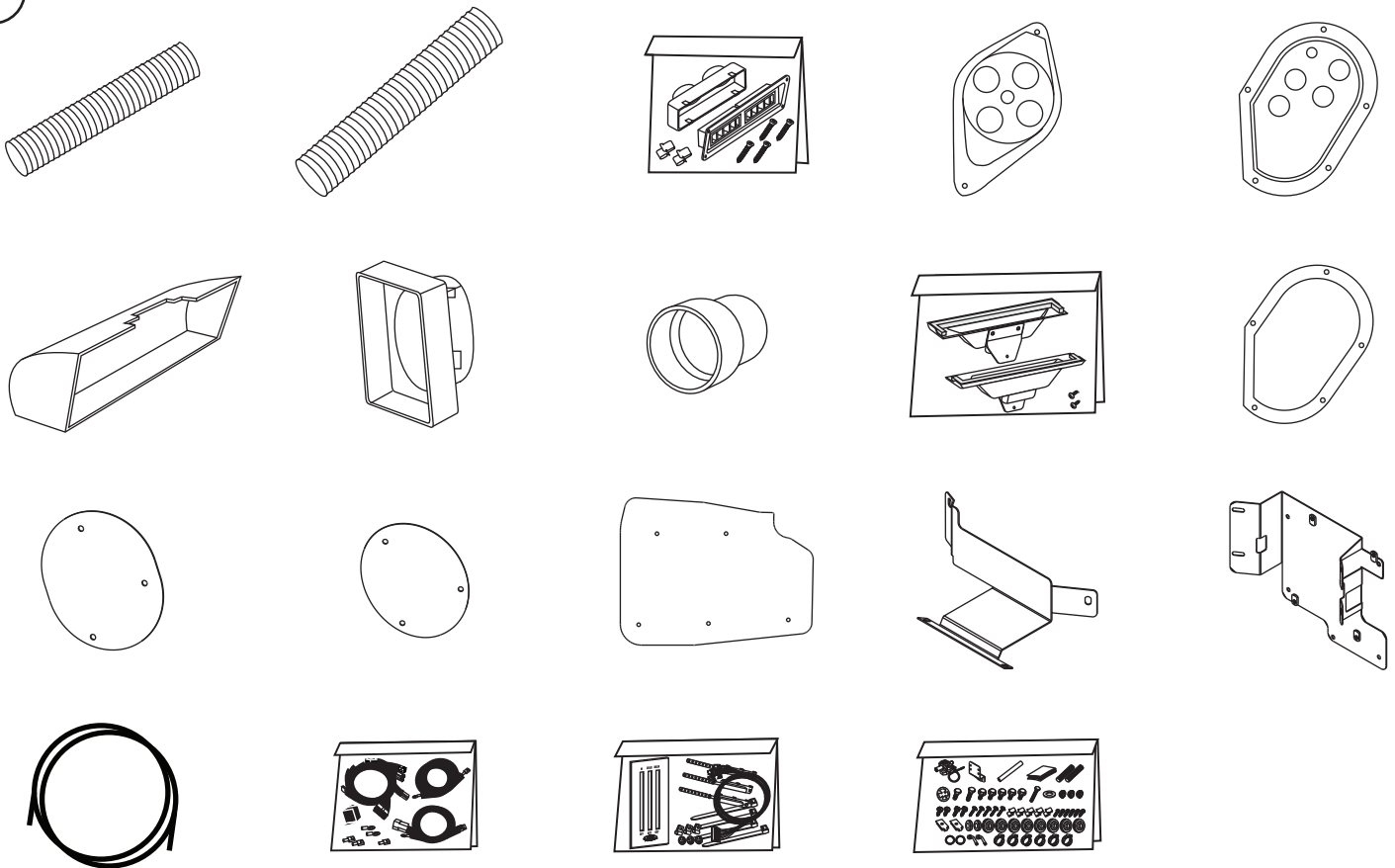
**\*\* Before beginning installation, open all packages and check contents of shipment. Please report any shortages directly to Vintage Air within 15 days. After 15 days, Vintage Air will not be responsible for missing or damaged items.**

1



Gen IV Evaporator  
Sub Case  
744004-VUE

2



Accessory Kit  
781191

**NOTE: Images may not depict actual parts and quantities. Refer to packing list for actual parts and quantities.**



www.vintageair.com

## Important Notice—Please Read

*For Maximum System Performance, Vintage Air Recommends the Following:*

**NOTE:** Vintage Air systems are designed to operate with R134a refrigerant only. Use of any other refrigerant could damage your A/C system and/or vehicle, and possibly cause a fire, in addition to potentially voiding the warranties of the A/C system and its components.

### Refrigerant Capacities:

**Vintage Air System:** 1.8 lbs. (28.8 oz.) or 816 grams of **R134a**, charged by weight with a quality charging station or scale. **NOTE: Use of the proper type and amount of refrigerant is critical to system operation and performance.**

**Other Systems:** Consult manufacturer's guidelines.

### Lubricant Capacities:

**New Vintage Air-Supplied Sanden Compressor:** No additional oil needed (Compressor is shipped with proper oil charge).

**All Other Compressors:** Consult manufacturer (Some compressors are shipped dry and will need oil added).

### Safety Switches

Your Vintage Air system is equipped with a binary pressure safety switch. A binary switch disengages the compressor clutch in cases of extreme low pressure conditions (refrigerant loss) or excessively high head pressure (406 PSI) to prevent compressor damage or hose rupture. A trinary switch combines Hi/Lo pressure protection with an electric fan operation signal at 254 PSI, and should be substituted for use with electric fans. Compressor safety switches are extremely important since an A/C system relies on refrigerant to circulate lubricant.

### Service Info:

**Protect Your Investment:** Prior to assembly, it is critical that the compressor, evaporator, A/C hoses and fittings, hardlines, condenser and receiver/drier remain capped. Removing caps prior to assembly will allow moisture, insects and debris into the components, possibly leading to reduced performance and/or premature failure of your A/C system. This is especially important with the receiver/drier.

Additionally, when caps are removed for assembly, **BE CAREFUL!** Some components are shipped under pressure with dry nitrogen.

**Evacuate the System for 35-45 Minutes:** Ensure that system components (Drier, compressor, evaporator and condenser) are at a temperature of at least 85°F. On a cool day, the components can be heated with a heat gun **or** by running the engine with the heater on before evacuating. Leak check and charge to specifications.

### Bolts Passing Through Cowl and/or Firewall:

To ensure a watertight seal between the passenger compartment and the vehicle exterior, for all bolts passing through the cowl and/or firewall, Vintage Air recommends coating the threads with silicone prior to installation.

### Heater Hose (not included with this kit):

Heater hose may be purchased from Vintage Air (Part#31800-VUD) or your local parts retailer. Routing and required length will vary based on installer preference.



www.vintageair.com

## Important Wiring Notice—Please Read

*Some vehicles may have had some or all of their radio interference capacitors removed. There should be a capacitor found at each of the following locations:*

- 1. On the positive terminal of the ignition coil.**
- 2. If there is a generator, on the armature terminal of the generator.**
- 3. If there is a generator, on the battery terminal of the voltage regulator.**

Most alternators have a capacitor installed internally to eliminate what is called “whining” as the engine is revved. If whining is heard in the radio, or just to be extra cautious, a radio interference capacitor can be added to the battery terminal of the alternator.

It is also important that the battery lead is in good shape and that the ground leads are not compromised. There should be a heavy ground from the battery to the engine block, and additional grounds to the body and chassis.

If these precautions are not observed, it is possible for voltage spikes to be present on the battery leads. These spikes come from ignition systems and charging systems, and from switching some of the vehicle’s other systems on and off. Modern computer-operated equipment can be sensitive to voltage spikes on the power leads, which can cause unexpected resets, strange behavior and/or permanent damage.

Vintage Air strives to harden our products against these types of electrical noise, but there is a point where a vehicle’s electrical system can be degraded so much that nothing can help.

Radio interference capacitors should be available at most auto and truck parts suppliers. They typically are cylindrical in shape, a little over an inch long and a little over a half inch in diameter, and they have a single lead coming from one end of the cylinder with a terminal on the end of the wire, as well as a mounting clip which is screwed into a good ground on the vehicle. The specific value of the capacitance is not too significant in comparison to ignition capacitors that are matched with the coil to reduce pitting of the points.

- Care must be taken, when installing the compressor lead, not to short it to ground. The compressor lead must not be connected to a condenser fan or to any other auxiliary device. Shorting to ground or connecting to a condenser fan or any other auxiliary device may damage wiring or the compressor relay, and/or cause a malfunction.
- When installing ground leads on Gen IV systems, the blower control ground and ECU ground must be connected directly to the negative battery post.
- For proper system operation, the heater control valve must be connected to the ECU.



www.vintageair.com

## Engine Compartment Disassembly

**NOTE:** Before starting the installation, check the function of the vehicle (horn, lights, etc.) for proper operation, and study the instructions, illustrations, & diagrams.

### Perform the Following:

1. Disconnect the battery.
2. Remove the battery and battery tray (retain) (See Figure 1, below).
3. Drain the radiator.
4. Remove the hood latch and hood latch support assembly (retain) (See Figure 1, below).
5. Remove the OEM heater hoses (discard) (See Figure 1, below).
6. Remove the OEM blower motor assembly (See Figure 1, below). **NOTE:** To remove the blower assembly (under hood) and the air distribution system (under dash), the factory manual recommends the following: Remove the right lower rocker molding. Remove the fender attaching bolts. Remove the skirt-to-fender and skirt-to-reinforcement screws. Pull out on the lower portion of the fender, moving the skirt away from the fender flange and firewall. Block the skirt with a 2" x 4" block of wood. To avoid damage to the paint and sheet metal, and for ease of removal and replacement of components, Vintage Air recommends that the right fender be removed, and the inner panel lowered. Removing the right front tire will provide easier access to the inner fender bolts.

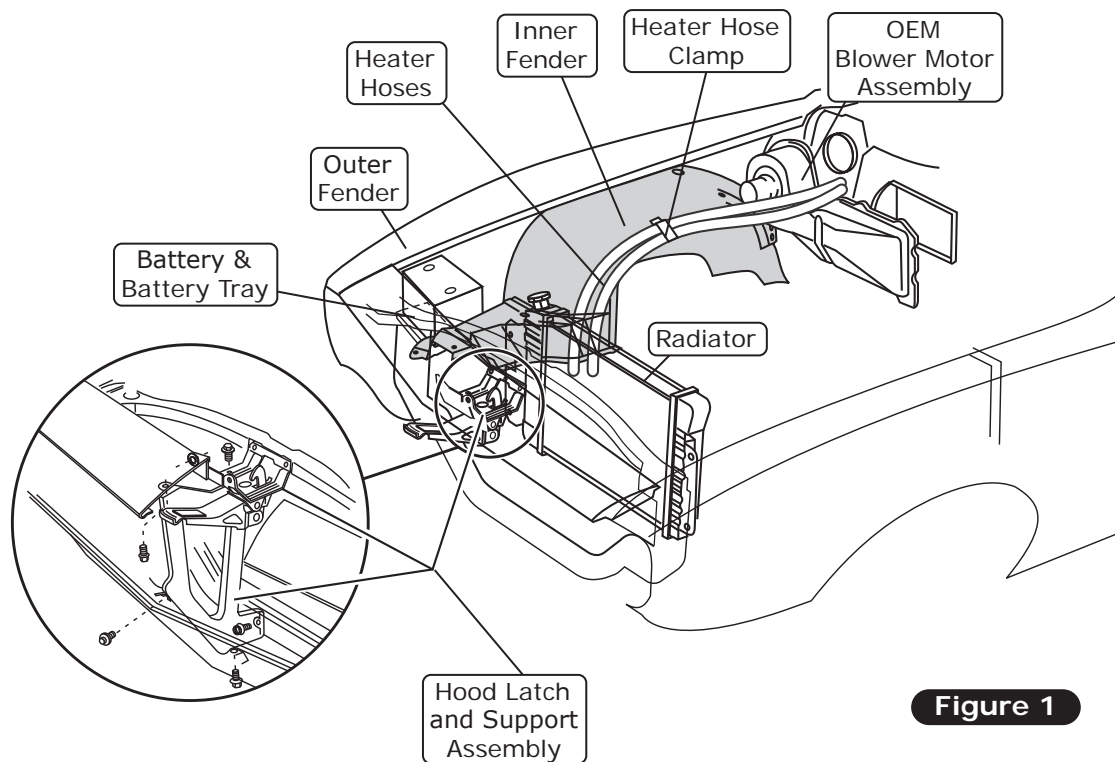


Figure 1

## Condenser Assembly and Installation

1. Refer to separate instructions included with the condenser kit to install the condenser.
2. Binary switch installation (Refer to condenser instructions).

## Compressor and Brackets

1. Refer to separate instructions included with the bracket kit to install the compressor bracket.



www.vintageair.com

## Dash Modification

1. Mark the dash area as shown in Photo 1, below. **NOTE: Offset the marked area 1/8" to the right of the dash padding/dash metal seam (See Photo 1, below). This will allow for the center louver bezel to seat flat against the dash padding. Do not exceed the dimensions shown in Photo 1, otherwise, the opening will encroach on the area for the installation of the mounting screws.**
2. Cut and remove the dash (See Photo 2, below).

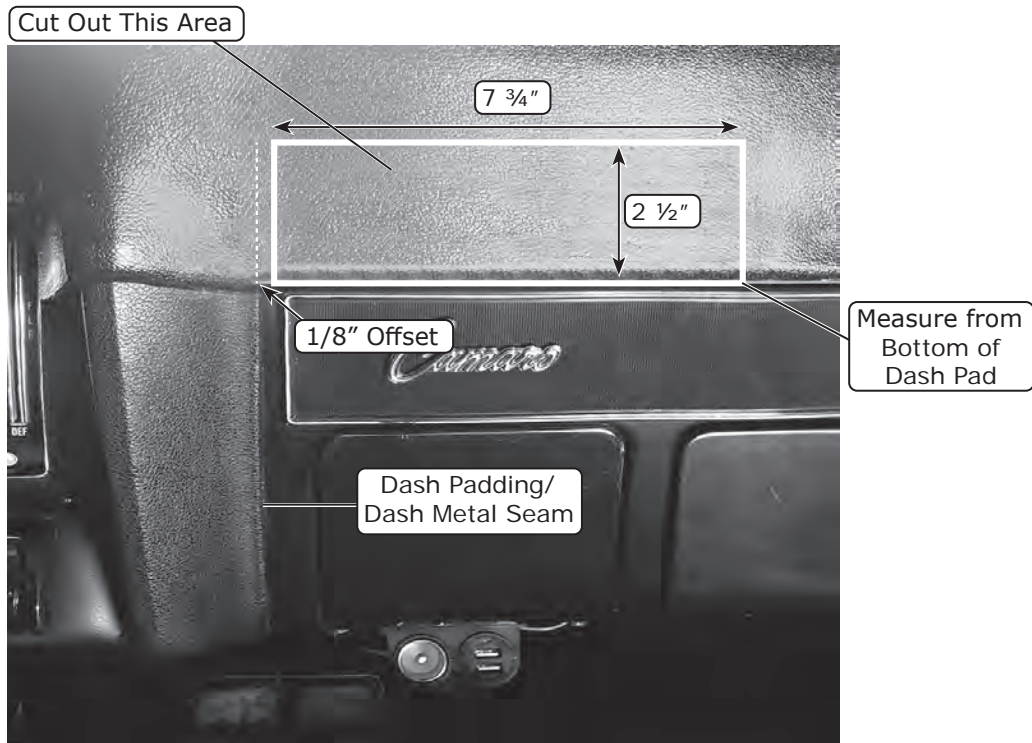


Photo 1



Photo 2



www.vintageair.com

## Passenger Compartment Disassembly

### Perform the Following:

1. Remove the OEM heater assembly (discard) (See Figure 1, below).
2. Remove the OEM defrost duct (discard) (See Figure 1, below).
3. Remove the steering column bottom cover (retain) (See Figure 1, below).
4. Remove the driver and passenger side vent ducts (discard) (See Figure 1, below).
5. Remove the OEM duct hoses (discard) (See Figure 1, below).
6. Remove the glove box door (retain) (See Figure 1, below).
7. Remove the glove box (discard) (See Figure 1, below).
8. Remove the instrument panel (retain) (See Figure 1, below).
9. Remove the OEM control panel (retain). **NOTE: Refer to control panel instructions for installation of controls.**
10. Lower the steering column.

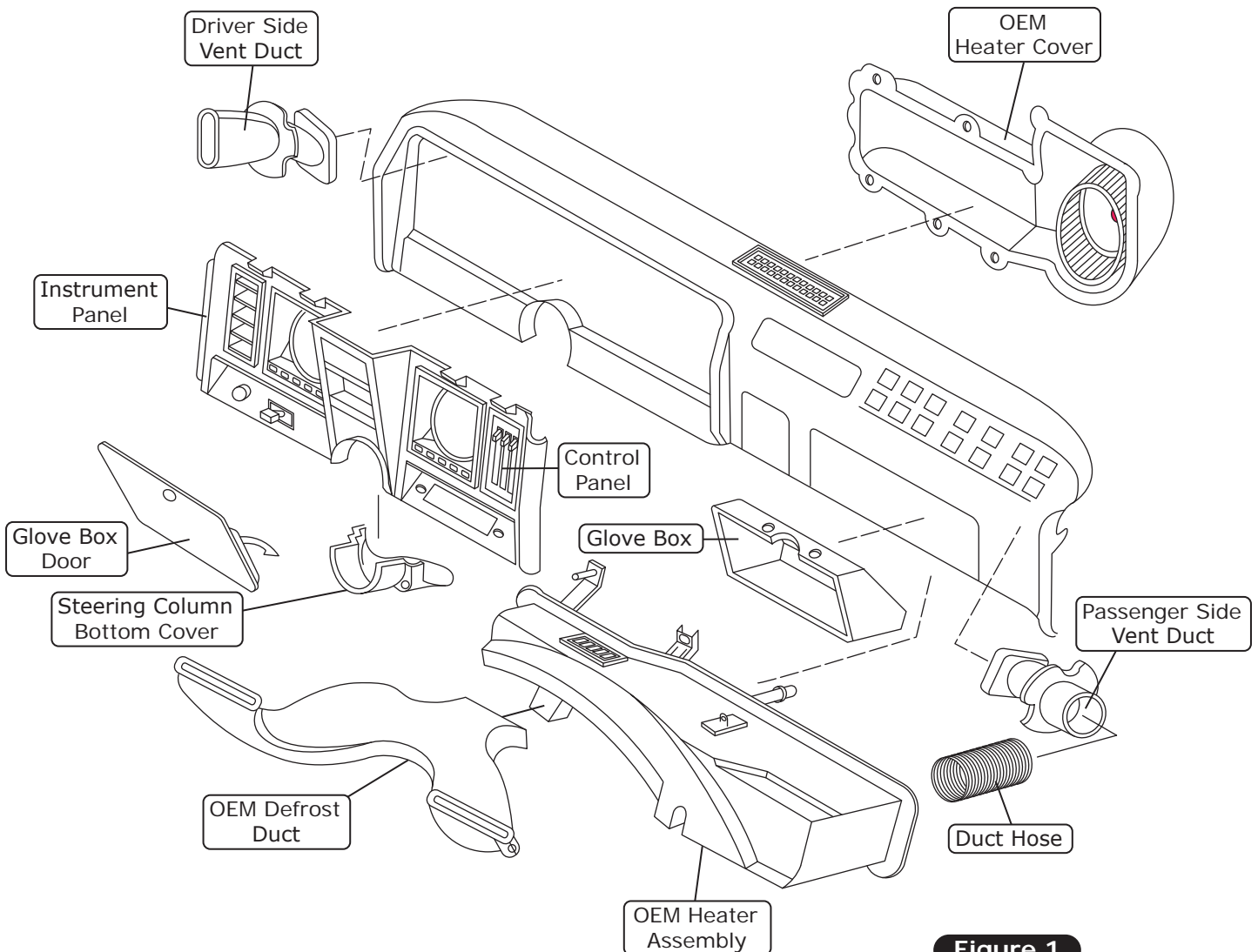


Figure 1



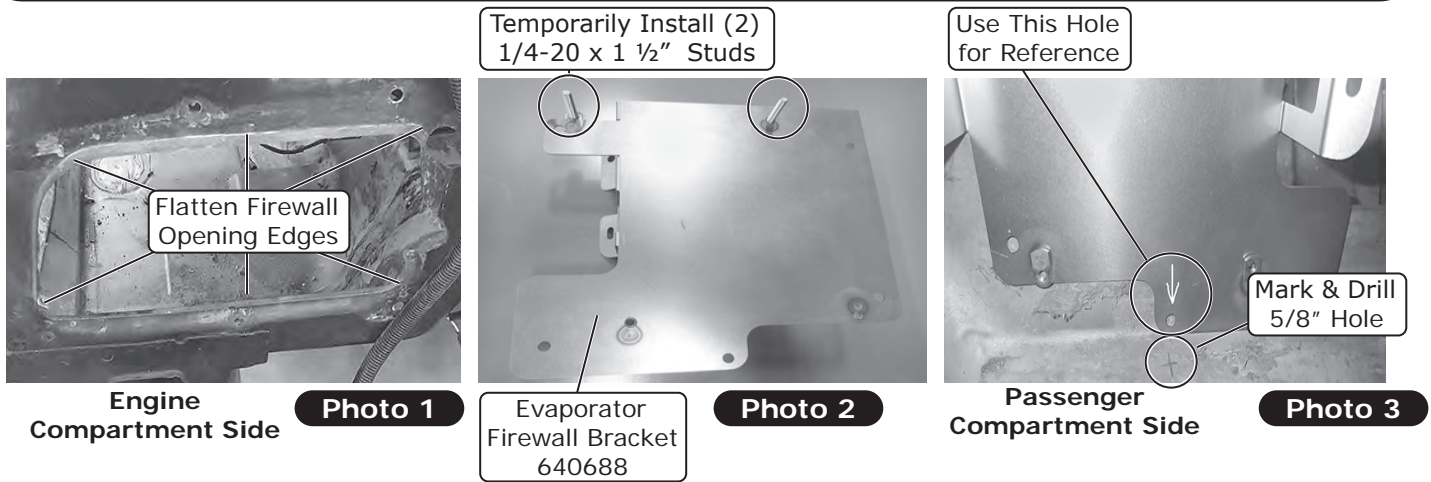


www.vintageair.com

## Firewall Modification

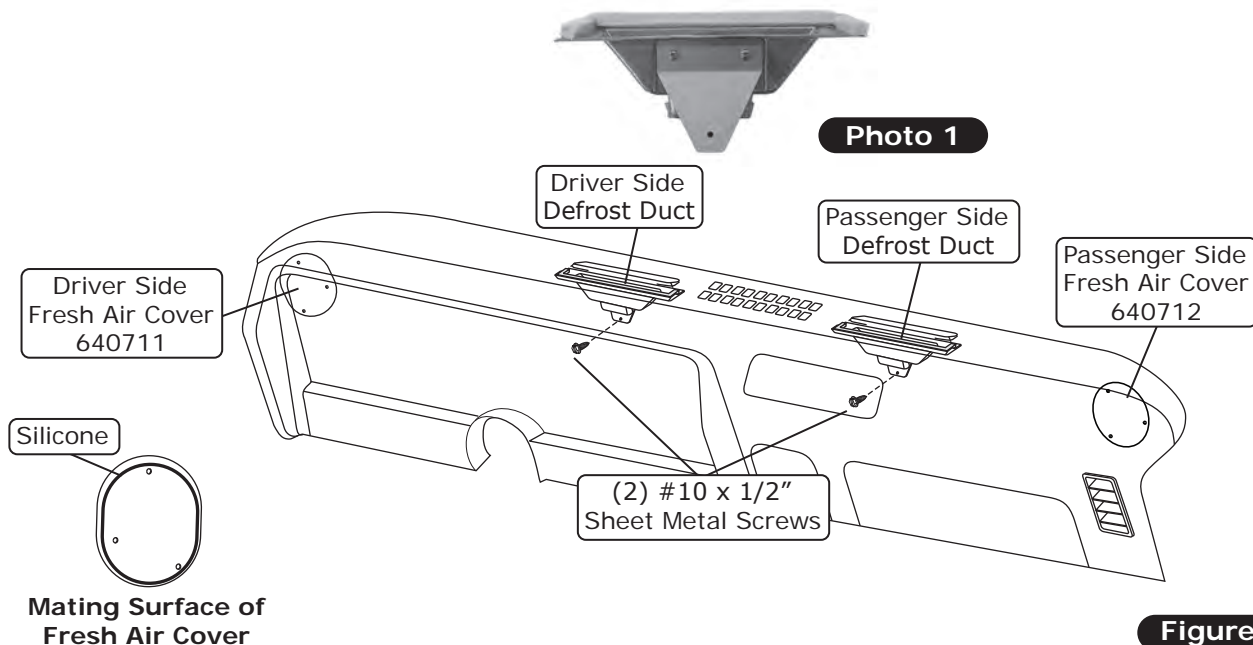
**NOTE: Firewall modification is required for firewall cover and drain hose installation.**

1. Flatten the edges of the firewall opening (See Photo 1, below).
2. Temporarily install (2) 1/4-20 x 1 1/2" studs into the evaporator firewall bracket as shown in Photo 2, below.  
**NOTE: This will align the bracket with the mounting holes in the firewall.**
3. From inside the passenger compartment, temporarily install the evaporator firewall bracket. Using the bottom hole on the evaporator firewall bracket as a reference, mark and drill a 5/8" hole for the drain hose as shown in Photo 3, below. **NOTE: To ensure a tight fit, do not enlarge the hole to more than 5/8".**
4. Remove the evaporator firewall bracket.



## Defrost Duct & Fresh Air Cover Installation

1. Locate the (2) defrost duct assemblies (See Photo 1, below)
2. Install the defrost ducts under the dash (See Figure 1, below). Align each defrost duct with the defrost opening in the dash, and hold it in place. Using the bracket as a template, drill a 7/64" hole for each duct as shown below. Secure each defrost duct using a #10 x 1/2" sheet metal screw (See Figure 1, below).
3. If the vehicle is equipped with astro ventilation, apply a 1/4" bead of silicone to the mating surface, and install the driver and passenger side fresh air covers, using OEM hardware to secure (See Figure 1, below).





www.vintageair.com

## Hose Adapter Installation

1. Install (4) S-clips onto the driver side hose adapter and (2) S-clips onto the passenger side hose adapter as shown in Figure 1, below.
2. Install the driver & passenger side hose adapters onto the OEM louvers (See Figure 1, below).

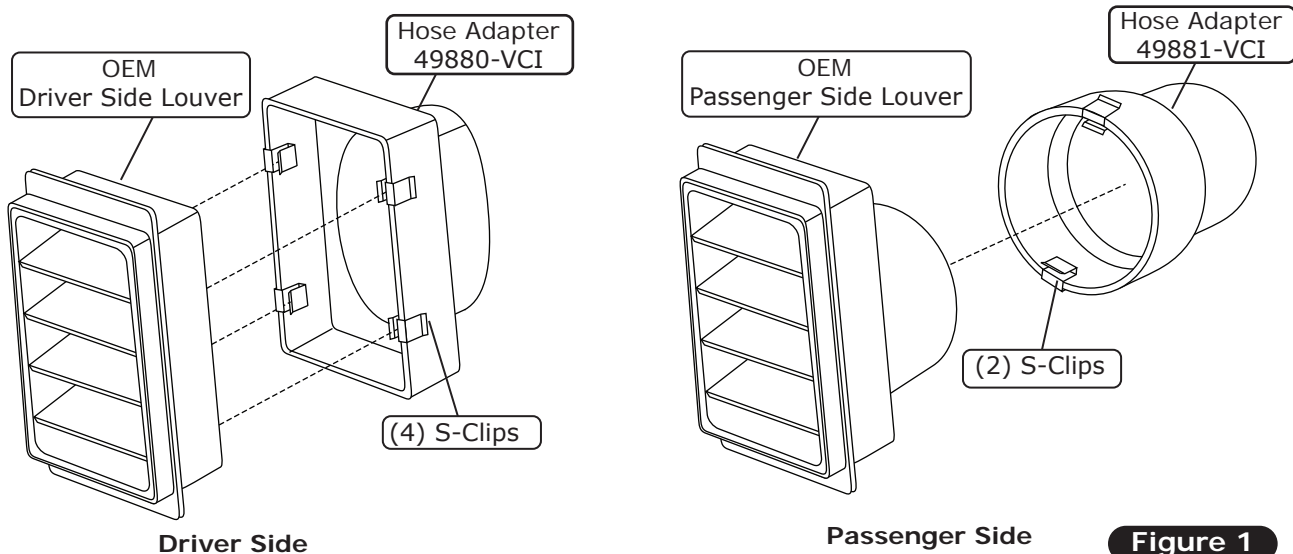


Figure 1

## Early-Model Kick Panel Modification

**NOTE: If the vehicle is equipped with a late-model kick panel, proceed to Page 11.**

1. Remove the OEM kick panel grille retaining screw and grille (discard) (See Photo 1, below).
2. Disconnect and remove the fresh air door cable from the OEM lever housing (discard) (See Photo 2, below).
3. Remove the fresh air door assembly from the OEM kick panel by lifting up on the door toward the spring and sliding it out of the hinge housing (See Photo 3, below).
4. Trim the fresh air door housing flush with the back of the OEM kick panel, and discard the excess material (See Photo 4, below).

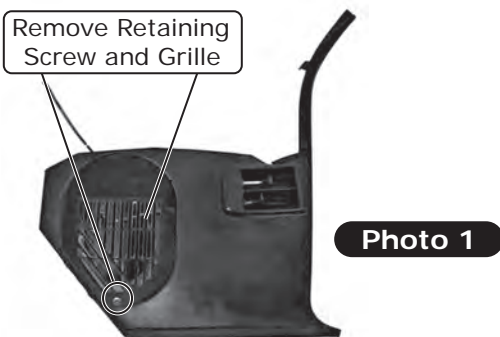


Photo 1



Photo 2



Photo 3



Photo 4



www.vintageair.com

## Late-Model Kick Panel Modification

1. Remove the fresh air door assembly from the OEM kick panel by lifting up on the door toward the spring and sliding it out of the hinge housing (See Photo 1, below).
2. Disconnect and remove the fresh air door cable from the OEM lever housing (discard) (See Photo 2, below).
3. Trim the fresh air door housing flush with the back of the OEM kick panel, and discard the excess material (See Photo 3, below).
4. Cut out the kick panel vent grille (See Photos 4 & 5, below).

Fresh Air Door Assembly

Lift Door Toward Spring to Remove

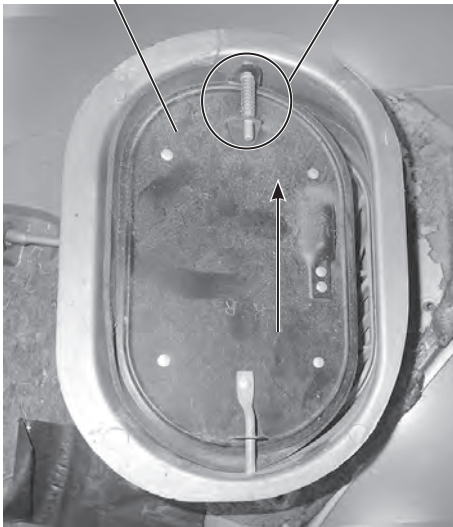


Photo 1

Disconnect Fresh Air Door Cable



Photo 2

Trim Flush with Kick Panel Housing

Fresh Air Door Housing

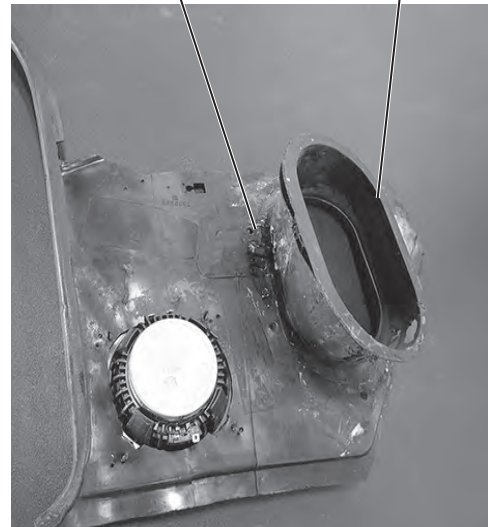


Photo 3

Cut Out Kick Panel Vent Grille

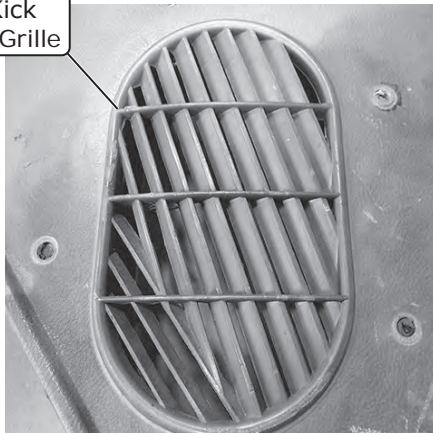


Photo 4

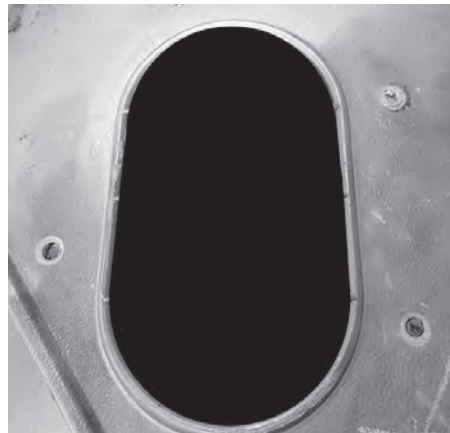


Photo 5



www.vintageair.com

## Firewall Cover Insulation

**NOTE:** For proper system operation, Vintage Air recommends using heat blocking insulation in the area around the evaporator unit (firewall, kick panel, inner cowl, firewall covers). Due to tight clearance for the evaporator unit between the firewall and dash, Vintage Air recommends an insulation thickness of no more than 1/4".

1. To apply insulation to the firewall cover, temporarily install the firewall cover onto the firewall using (2) 1/4-20 x 3/4" bolts and (2) 1/4-20 nuts with star washers (See Photo 1, below).
2. From the passenger compartment, trace the firewall opening onto the firewall cover (See Photo 2, below).
3. Remove the firewall cover, and apply insulation to the traced area (See Photo 3, below).

Temporarily Install Firewall Cover with (2) 1/4-20 x 3/4" Bolts & (2) 1/4-20 Nuts with Star Washers



Firewall Cover  
640687

Photo 1

Trace Firewall Opening

Firewall Cover  
640687



Passenger  
Compartment View

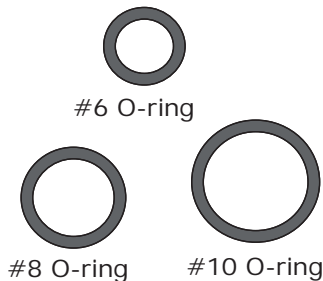
Photo 2

Apply Insulation to Traced Area

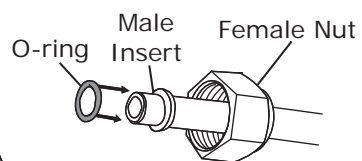


Photo 3

## Lubricating O-rings



**NOTE: Standard torque specifications:**  
 #6: 11 to 13 ft-lb.  
 #8: 15 to 20 ft-lb.  
 #10: 21 to 27 ft-lb.



For a proper seal of fittings: Install supplied O-rings as shown and lubricate with supplied oil.

Supplied Oil for O-rings

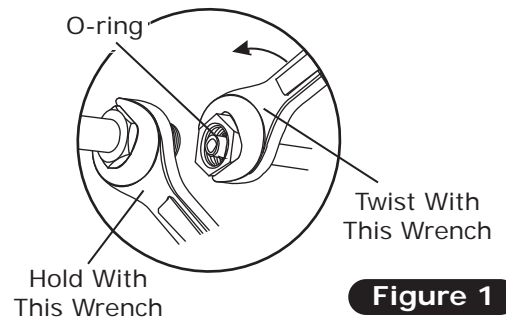
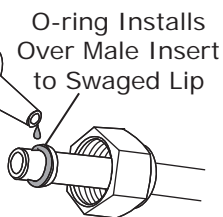


Figure 1



www.vintageair.com

## Evaporator Bracket & Heater Hardline Installation

1. On a workbench, install the upper heater hardline onto the evaporator unit using a properly lubricated #10 O-ring (See Figure 1, Page 12, and Photo 1, below).
2. Install the lower heater hardline onto the evaporator unit using a properly lubricated #10 O-ring (See Figure 1, Page 12, and Photo 2, below). **NOTE: Install the upper and lower hardlines facing downward as shown in Photo 2, below.**
3. Install the evaporator firewall bracket using (4) 1/4-20 x 1/2" bolts (supplied on the evaporator unit) (See Photo 3, below).

Install Upper Heater Hardline

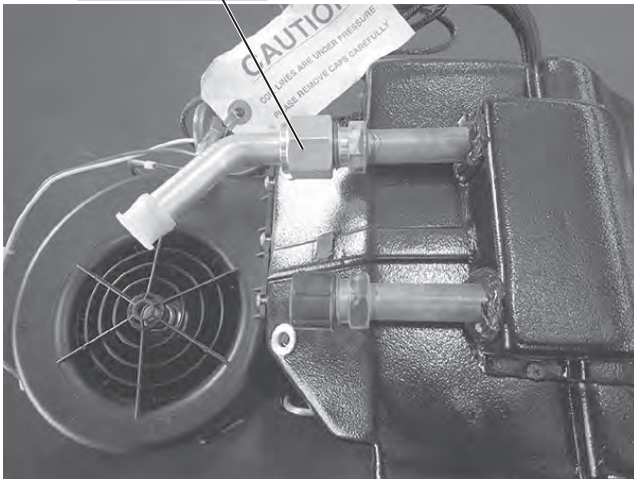
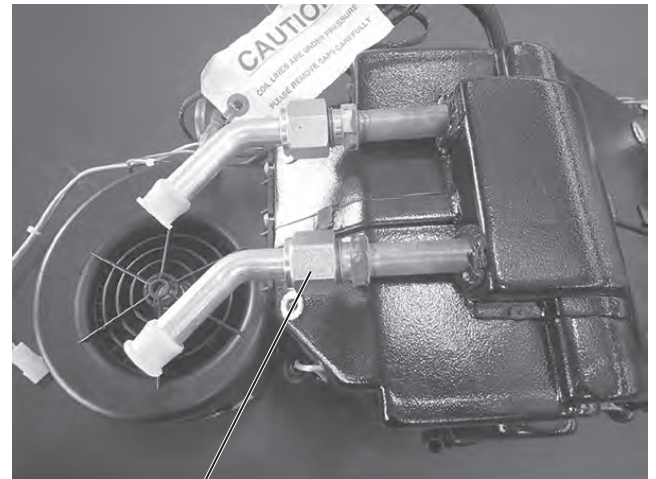


Photo 1



Install Lower Heater Hardline

Photo 2

Install Evaporator Firewall Bracket Using (4) 1/4-20 x 1/2" Bolts (Supplied on Evaporator Unit)



Evaporator Firewall Bracket  
640688

Photo 3



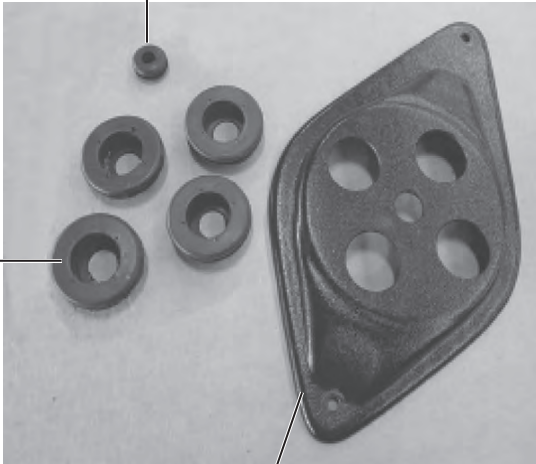
www.vintageair.com

## Fresh Air Cap & Kick Panel Cover Preparation

1. Install (4) large grommets and a 7/8" grommet into the fresh air cap (See Photos 1 and 2, below).
2. Install (4) large grommets and a 7/8" grommet into the kick panel cover (See Photos 3 and 4, below).

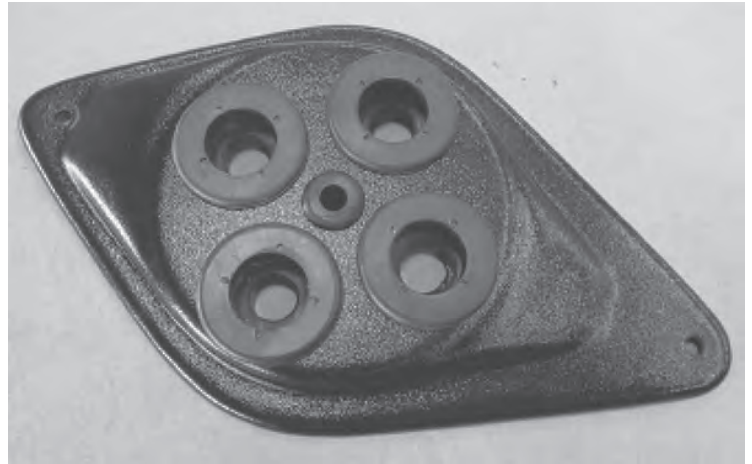
7/8" Grommet  
33144-VUI

(4) Large  
Grommets  
33137-VUI



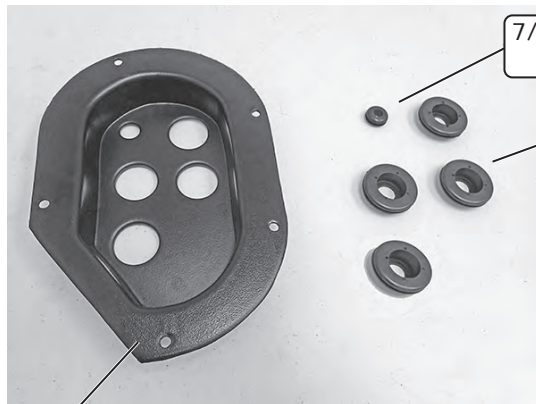
Fresh Air  
Cap 622230

Photo 1



Completed Installation

Photo 2



Kick Panel  
Cover 622235

Photo 3

7/8" Grommet  
33144-VUI

(4) Large  
Grommets  
33137-VUI



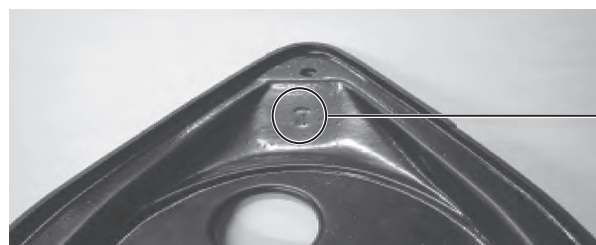
Completed  
Installation

Photo 4

## Heater and A/C Hose Installation

**NOTE:** Soapy water may be used to ease insertion of A/C and heater hoses through the grommets, but be sure the hoses are capped to prevent water from getting inside.

1. On the inside of the fresh air cap, the letter "T" indicates the top mounting hole for the firewall (See Photo 1, below).



"T" Indicates  
Top Mounting Hole

Photo 1



www.vintageair.com

## Heater and A/C Hose Installation (Cont.)

1. Insert a length of heater hose through the bottom right large grommet on the fresh air cap (See Photo 2, below).
2. Insert a length of heater hose through the top right large grommet on the fresh air cap (See Photo 3, below).
3. Insert the straight fitting on the #6 drier/evaporator A/C hose through the bottom left large grommet on the fresh air cap (See Photo 4, below).
4. Insert the 45° fitting on the #10 compressor/evaporator A/C hose through the top left large grommet on the fresh air cap (See Photo 5, below). **NOTE: Temporarily remove the large grommet from the fresh air cap to ease insertion of the #10 hose fitting.**
5. From the passenger compartment, insert the lower heater hose through the bottom left large grommet on the kick panel cover (See Photo 6, below).
6. Insert the upper heater hose through the top left large grommet on the kick panel cover (See Photo 7, below).
7. Insert the #6 drier/evaporator A/C hose through the bottom right large grommet on the kick panel cover (See Photo 8, below).
8. Insert the #10 compressor/evaporator A/C hose through the top right grommet on the kick panel cover (See Photo 9, below). **NOTE: Temporarily remove the grommet from the kick panel cover for easier insertion.**

Fresh Air Cap  
622230

Large Grommet  
33137-VUI

Heater  
Hose

#6 Drier/Evaporator  
A/C Hose

#10 Compressor/  
Evaporator A/C Hose



Heater  
Hose

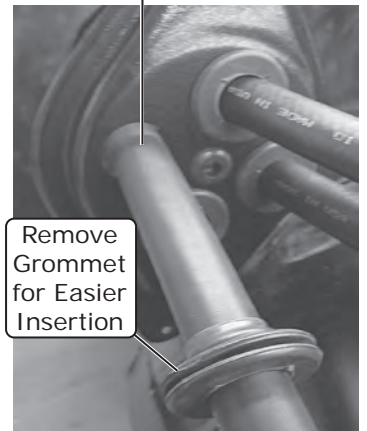
Photo 2



Photo 3



Photo 4



Remove  
Grommet  
for Easier  
Insertion

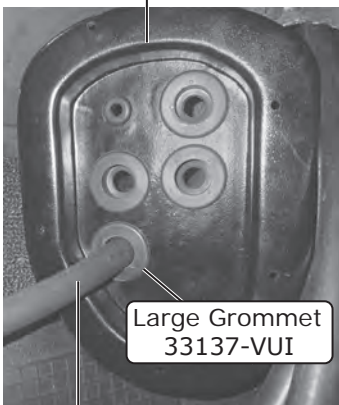
Photo 5

Kick Panel Cover  
622235

Upper  
Heater Hose

#6 Drier/Evaporator  
A/C Hose

#10 Compressor/  
Evaporator A/C Hose



Large Grommet  
33137-VUI

Lower  
Heater Hose

Photo 6



Photo 7

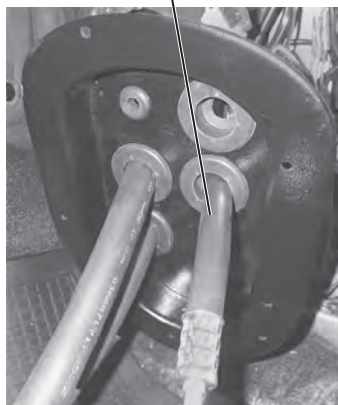


Photo 8

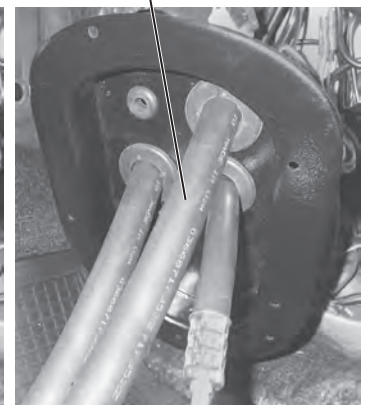


Photo 9



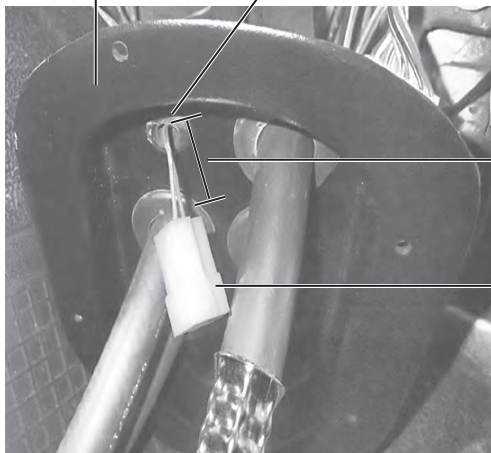
www.vintageair.com

## Wiring Installation

1. From the passenger compartment, route the heater control valve connector and wiring (red, white and green) through the 7/8" grommet in the kick panel cover and through the 7/8" grommet in the fresh air cap (See Photo 1, below). **NOTE: Leave approximately 1" of wiring between the kick panel cover and the harness connector. This allows enough wiring to reach the harness.**
2. Disconnect the circuit breaker from the main wiring harness (See Photo 2, below).
3. Route the red, white and blue wires from the main wiring harness through the 7/8" grommet in the kick panel cover (See Photo 3, below). **NOTE: Leave approximately 5" of wiring between the relay and the kick panel cover. This allows enough wiring to secure the relay to the mounting position.**
4. Route the heater control valve wiring (red, white and green) through the 7/8" grommet in the fresh air cap (See Photo 4, below).
5. Route the main harness wiring (red, white and blue) through the 7/8" grommet in the fresh air cap (See Photo 5, below).

Kick Panel Cover  
622235

7/8" Grommet  
33144-VUI



Approximately 1"

Heater Control Valve Connector and Wiring (Red, White and Green)

Photo 1

Circuit Breaker

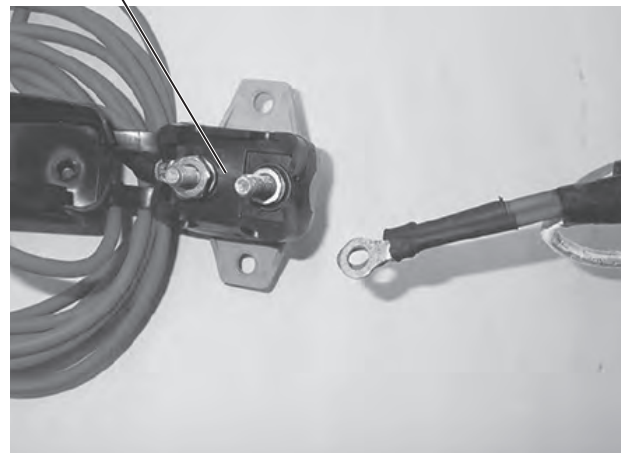


Photo 2

Kick Panel Cover  
622235

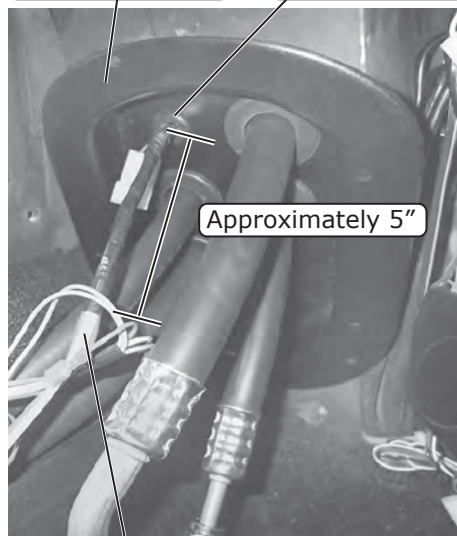
7/8" Grommet  
33144-VUI

Fresh Air Cap  
622230

7/8" Grommet  
33144-VUI

Fresh Air Cap  
622230

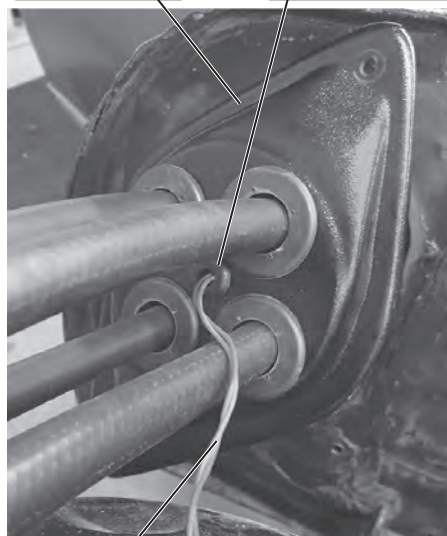
7/8" Grommet  
33144-VUI



Approximately 5"

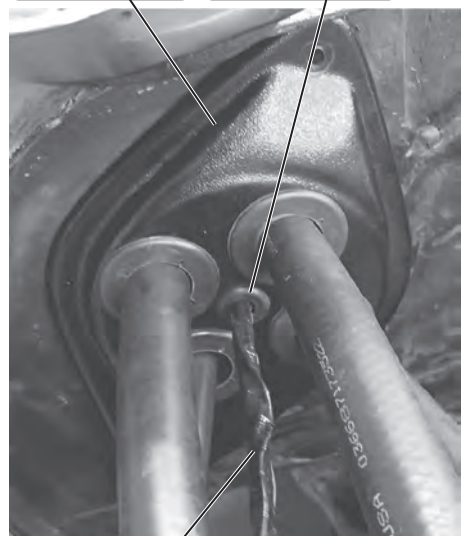
Main Wiring Harness  
(Red, White and Blue)

Photo 3



Heater Control Valve Wiring  
(Red, White and Green)

Photo 4



Main Wiring Harness  
(Red, White and Blue)

Photo 5





www.vintageair.com

## Kick Panel Installation

1. Apply a bead of silicone around the mating surface of the kick panel cover (See Figure 1, below).
2. Install the kick panel cover into place, lining up the mounting holes on the cover with the OEM mounting holes on the kick panel opening (See Photo 1, below).
3. Install the kick panel, routing the hoses and wiring through the opening (See Photo 2, below). For an early-model kickpanel, secure the panel with the trim plate using (3) #8 x 3/4" countersunk washer screws (See Photo 3, below). For a late-model kick panel, do not install the trim plate. Secure the kick panel using (3) #8 x 3/4" countersunk washer screws.
4. Secure the main wiring harness relay to the upper kick panel mounting hole using a #8 x 3/4" countersunk washer screw, mounting it in the hole as shown in Photo 4, below. **NOTE: If your vehicle is equipped with a kick panel vacuum vent actuator cover, it will need to be modified to fit with the installed hoses (See Photo 5, below).**

Silicone Mating Surface

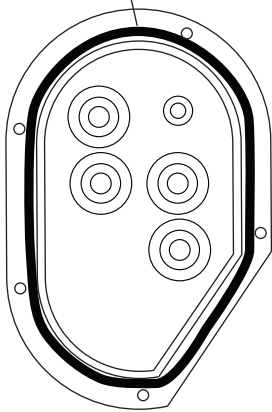


Figure 1

Install Kick Panel Cover into Place, Lining up Mounting Holes

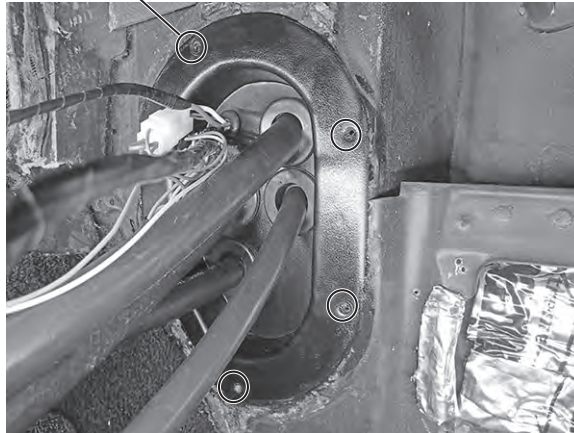


Photo 1

Install Kick Panel

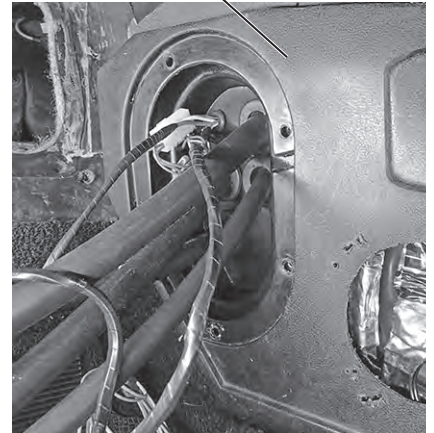


Photo 2

Kick Panel Trim Plate  
640709

(3) #8 x 3/4" Countersunk  
Washer Screws



Photo 3

Secure Relay to Upper  
Mounting Hole Using #8 x 3/4"  
Countersunk Washer Screw



Photo 4

Modified OEM Kick Panel  
Vacuum Vent Actuator Cover



Photo 5



www.vintageair.com

# Evaporator Installation

**NOTE: A 10" block of wood may be used to support the evaporator unit while the following steps are completed.**

1. Place the evaporator unit under the dash (See Photo 1, below).
2. Install the straight fitting on the #6 drier/evaporator A/C hose onto the expansion valve on the evaporator unit using a properly lubricated #6 O-ring (See Figure 1, Page 12, and Photo 2, below).
3. Install the upper heater hose and a hose clamp onto the upper heater hardline on the evaporator unit (See Photo 3, below).
4. Install the lower heater hose and a hose clamp onto the lower heater hardline on the evaporator unit (See Photo 4, below).
5. Remove the support board (if used), and roll the evaporator into its mounting position. Insert the (2) 1/4-20 x 1 1/2" studs into the upper OEM mounting holes on the firewall (See Photo 5, below).
6. Install the 45° fitting on the #10 compressor/evaporator A/C hose onto the #10 fitting on the evaporator using a properly lubricated #10 O-ring (See Figure 1, Page 12, and Photo 6, below). **NOTE: After installing the #10 compressor/evaporator A/C hose, wrap all exposed metal with the supplied press tape (See Photo 7, below).**

Place Unit Under Dash

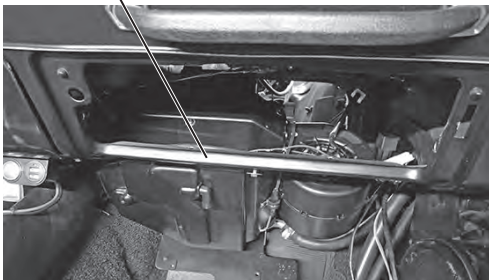


Photo 1

Install #6 Straight Fitting onto Expansion Valve

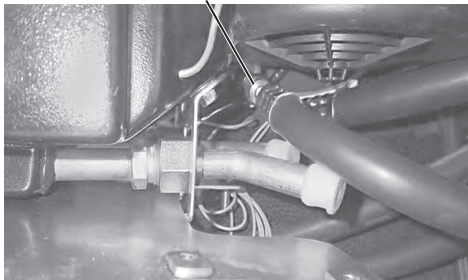


Photo 2

Install Upper Heater Hose onto Upper Heater Hardline

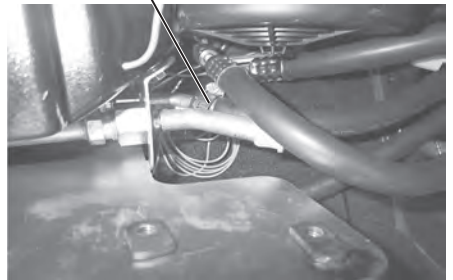


Photo 3

Install Lower Heater Hose onto Lower Heater Hardline

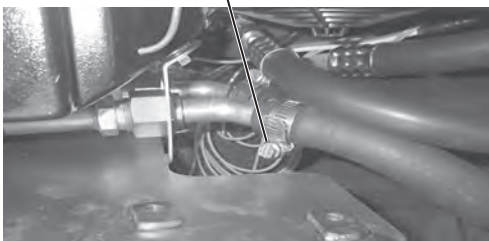


Photo 4

Insert (2) 1/4-20 x 1 1/2" Studs into Mounting Holes



Photo 5

Install #10 A/C Hose 45° Fitting onto #10 Evaporator Fitting



Photo 6

Wrap All Exposed Metal with Press Tape



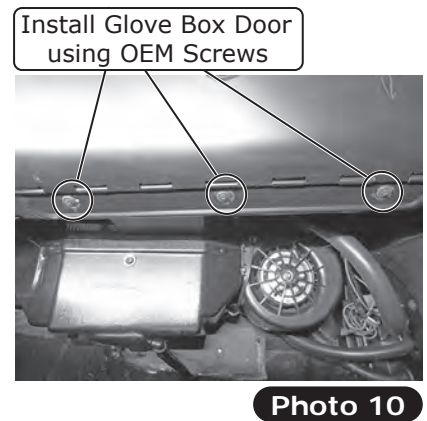
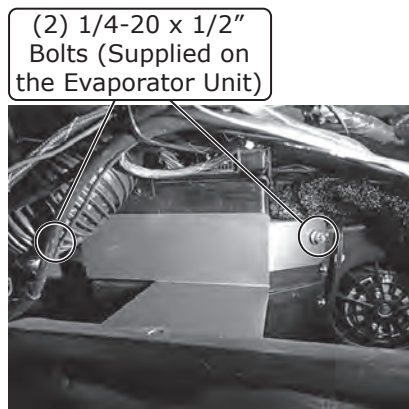
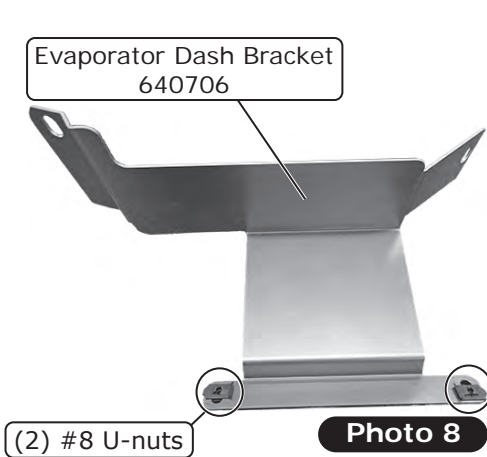
Photo 7



www.vintageair.com

## Evaporator Installation (Cont.)

7. Locate the evaporator dash bracket (See Photo 8, below).
8. Install the (2) #8 U-nuts onto the bracket as shown in Photo 8, below.
9. Install the dash bracket onto the evaporator unit using (2) 1/4-20 x 1/2" bolts (supplied on the evaporator unit).  
**NOTE: Do not fully tighten the bolts at this time.**
10. Install the glove box door using the (3) OEM screws, ensuring the screws install into the (3) #8 U-nuts on the dash bracket (See Photo 10, below). **NOTE: The use of a mirror can be used to verify the screws are correctly installed.**
11. Adjust and tighten the bolts on the dash bracket as shown in Photo 9, below.



## Drain Hose Installation

1. Install the drain hose through the previously drilled 5/8" hole in the firewall. Attach the drain hose onto the drain outlet on the bottom of the evaporator unit (See Photo 1, below).





www.vintageair.com

## Firewall Cover Installation

**NOTE:** To ensure a watertight seal between the passenger compartment and the exterior, for all bolts passing through the firewall, Vintage Air recommends coating the threads with silicone prior to installation.

1. Locate the bottom left mounting hole on the firewall cover, and install a 1/4-20 x 3/4" mounting bolt and a 1/4" pushnut bolt retainer (See Photos 1 & 2, below).
2. Apply a bead of silicone around the mating surface of the firewall cover (See Photo 2, below).
3. Install the firewall cover over the (2) 1/4-20 x 1 1/2" studs, and secure it using (2) 1/4-20 nuts with star washers to keep the firewall cover and evaporator unit in place (See Photo 3, below).
4. Install (2) 1/4-20 x 3/4" bolts into the remaining open mounting holes in the firewall cover and into the evaporator firewall bracket (See Photo 4, below). **NOTE: Do not tighten at this time.**
5. Remove the (2) 1/4-20 nuts with star washers and (2) 1/4-20 x 1 1/2" studs from the firewall cover, and replace them with (2) 1/4-20 x 3/4" bolts (See Photo 5, below). **NOTE: Do not tighten at this time.**
6. In the passenger compartment, install a 9/32" washer and a 1/4-20 nut with star washer onto the bottom right firewall cover bolt as shown in Photo 6, below. **NOTE: Do not tighten at this time.**
7. Verify that the evaporator unit is level and square to the dash. **NOTE: To ensure proper drainage, it is very important that the evaporator is level, both left-right and fore-aft. Check for level on the flat portions of the case around the drain.**
8. Tighten all of the mounting bolts at this time. **NOTE: Tighten the bolts on the firewall first. Adjust the evaporator dash bracket as needed, and then tighten the bolts on the evaporator unit. Silicone or seam sealer may be applied around the outer edge of the firewall cover.**

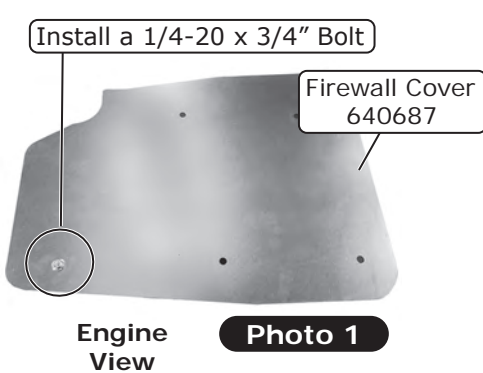


Photo 1

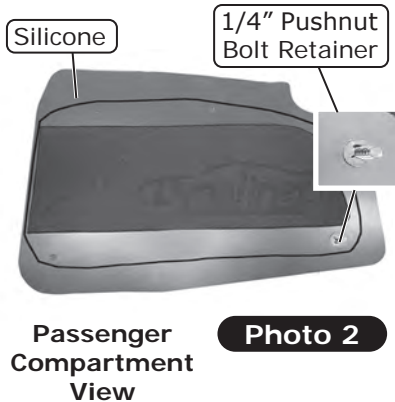


Photo 2

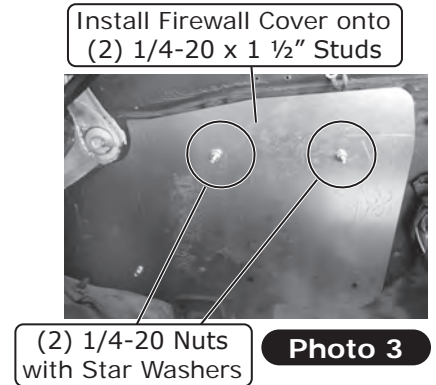


Photo 3

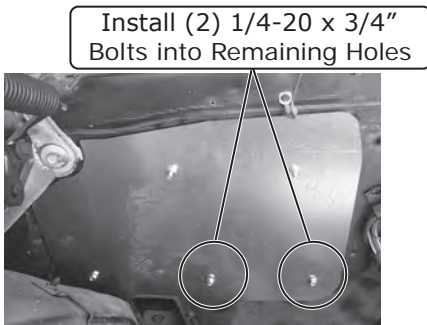


Photo 4

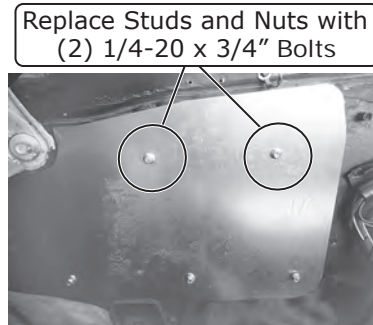


Photo 5



Photo 6



www.vintageair.com

## ECU Wiring Harness Installation

1. Route the violet power wire to a switched 12v power source on the fuse panel (See Photo 1, below).
2. Plug the white connector from the heater control valve into the white connector on the main wiring harness (See Photo 2, below).
3. Plug the white two-wire connector from the main wiring harness into the white connector on the blower motor (See Photo 3, below).
4. Plug the main wiring harness into the ECU (See Photo 4, below).

Attach Violet Wire to Switched Power Source

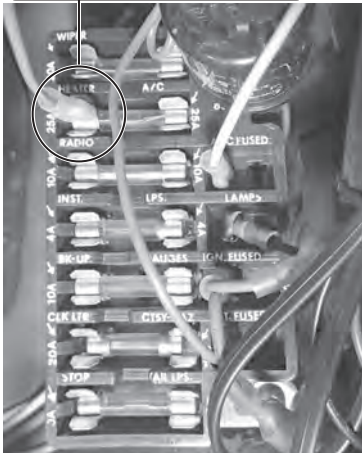


Photo 1

Main Wiring Harness Connector  
Heater Control Valve Connector

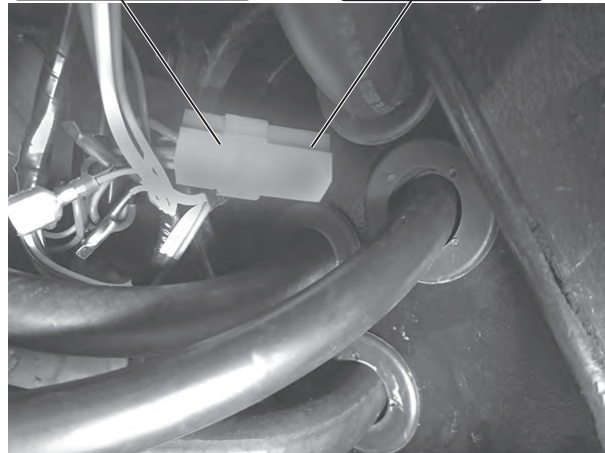


Photo 2

Main Wiring Harness Connector  
Blower Motor Connector



Photo 3

Plug Main Wiring Harness into ECU

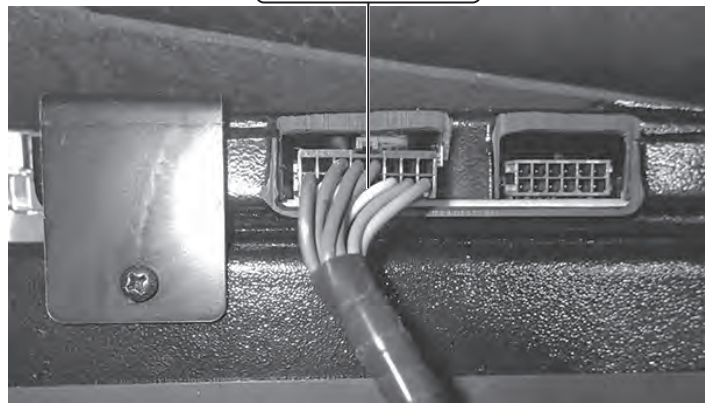
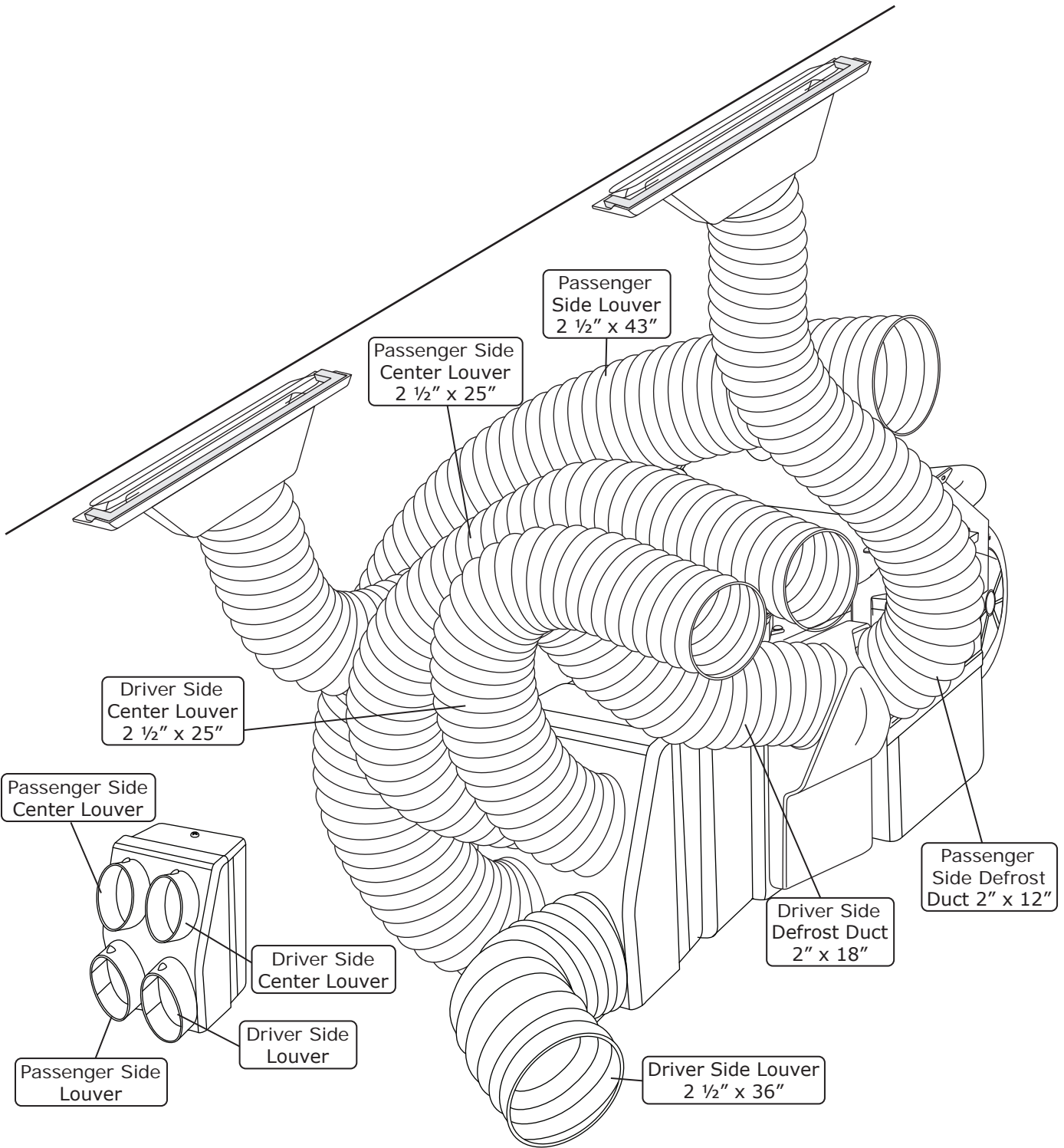


Photo 4



# Duct Hose Installation



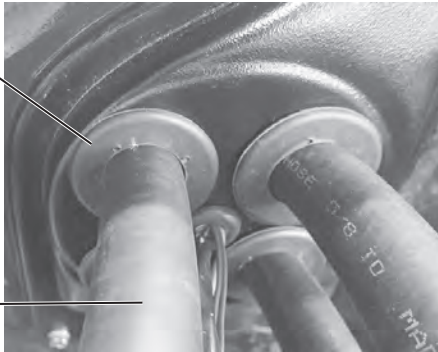


www.vintageair.com

## Fresh Air Cap Installation

1. Reinstall the large grommet on the #10 compressor/evaporator A/C hose into the fresh air cap (See Photo 1, below).
2. Gently pull the slack from the hoses in the passenger compartment, making sure the hoses are not kinked.
3. Slide the fresh air cap into position, and secure it to the firewall using (2) #14 x 3/4" sheet metal screws (See Photo 2, below).
4. Apply silicone around the outer edge of the fresh air cap (See Photo 2, below).

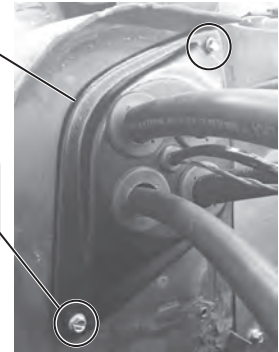
Reinstall Large Grommet into Fresh Air Cap



#10 Compressor/  
Evaporator A/C Hose  
090176

Photo 1

Apply Silicone Around Fresh Air Cap



Secure Fresh Air Cap with (2) #14 x 3/4" Sheet Metal Screws

Photo 2

## A/C Hose Installation

### Standard Hose Kit:

1. Locate the #8 condenser/compressor A/C hose. Lubricate (2) #8 O-rings (See Figure 1, Page 12), and connect the #8 90° fitting with service port to the #8 discharge port on the compressor (See Photo 2, below). Then route the 45° fitting to the #8 condenser/core hardline coming from the condenser (See Photo 3, below). Tighten each fitting connection (See Figure 1, Page 12).
2. Locate the #10 compressor/evaporator A/C hose. Lubricate a #10 O-ring (See Figure 1, Page 12), and connect the #10 135° fitting with service port to the #10 suction port on the compressor (See Photo 2, below). Tighten the fitting connection (See Figure 1, Page 12).
3. Locate the #6 drier/evaporator hose. Lubricate a #6 O-ring (See Figure 1, Page 12), and connect it to the #6 drier/fenderwell hardline coming from the condenser (See Photo 3, below). Tighten the fitting connection (See Figure 1, Page 12).

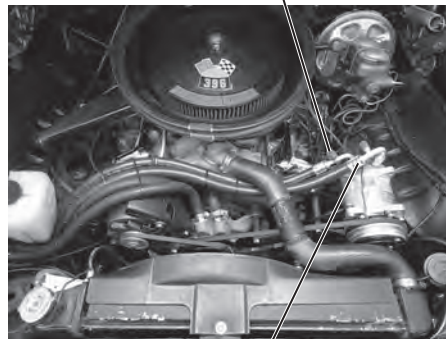
### Modified Hose Kit:

1. Refer to separate instructions included with modified hose kit.



Photo 1

#8 Compressor/  
Evaporator A/C Hose  
090175



#10 Compressor/  
Evaporator A/C Hose  
090176

Photo 2

#6 Drier/Evaporator  
A/C Hose  
090174

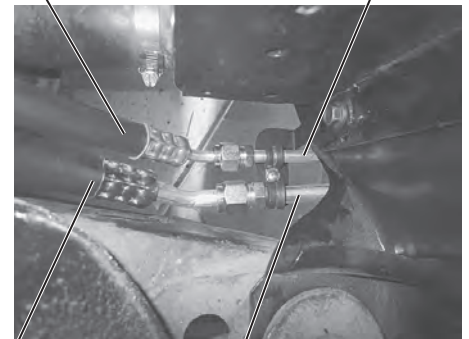


Photo 3

#6 Drier/Fenderwell  
Hardline  
090173

#8 Compressor/  
Evaporator A/C Hose  
090175

#8 Condenser/  
Core Hardline  
35367-VCG



www.vintageair.com

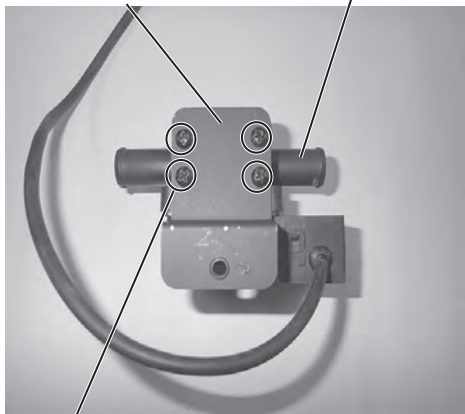
## Heater Control Valve Installation

**NOTE: Vintage Air Systems use 5/8" heater connections. On engines equipped with 3/4" hose nipples, these will need to be removed and replaced with 5/8" nipples (not supplied). For water pumps with a cast-in 3/4" heater outlet, a 3/4" x 5/8" reducer fitting in the heater hose (not supplied) or molded hose (Vintage Air Part #099010) will need to be installed.**

1. Install the heater control valve support bracket onto the heater control valve using (4) #8 x 1/2" screws (See Photo 1, below). **NOTE: Before mounting the heater control valve in the vehicle, ensure that the wiring from the main harness and heater control valve can be connected easily without tension or strain on the connection, or excessive pressure on the metal surfaces.**
2. Route a piece of heater hose (not provided) from the lower heater core fitting to the water pump. Secure using hose clamps. (See Photo 2, below).
3. Route a piece of heater hose (not provided) from the intake manifold to the heater control valve. Connect the heater hose from the upper heater core fitting to the heater control valve. Secure using hose clamps (See Figure 1 and Photo 3, below). **NOTE: Ensure proper flow direction through the heater control valve (the flow direction follows the molded arrow on the valve).**
4. Plug the heater control valve connector into the connector on the main wiring harness (See Photo 4, below). **NOTE: Secure the white wire from the heater control valve portion of the main harness to a suitable chassis ground.**
5. Install a #10 Adel clamp to secure the #8 A/C hose, and secure the heater hoses using tie wraps (See Photo 5, below). **NOTE: Use an OEM hole to mount the Adel clamp. If an OEM hole is not available, a new hole will need to be drilled. Be sure all hoses are routed away from the fan, belts and pulleys.**

Heater Control Valve Support Bracket  
648284

Heater Control Valve  
461171



(4) #8 x 1/2" Screws

Photo 1

Route Hose From Lower Heater Core Fitting to Water Pump

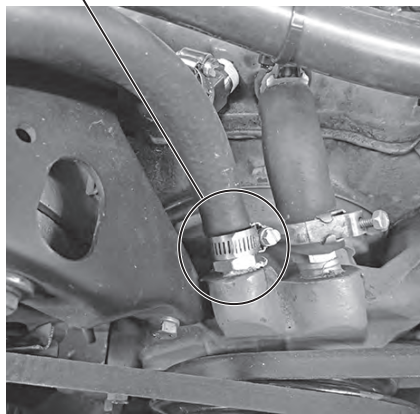


Photo 2

Intake Manifold Connection

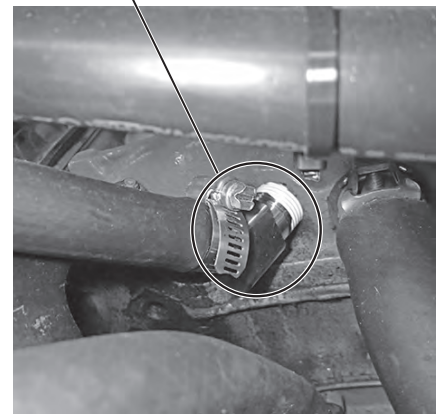
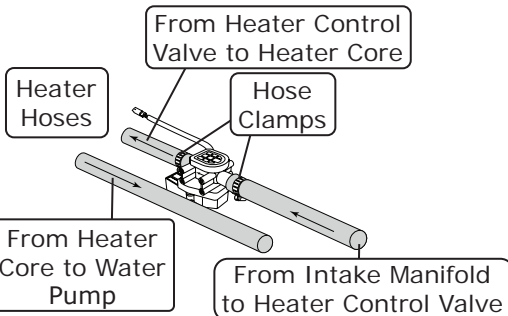


Photo 3

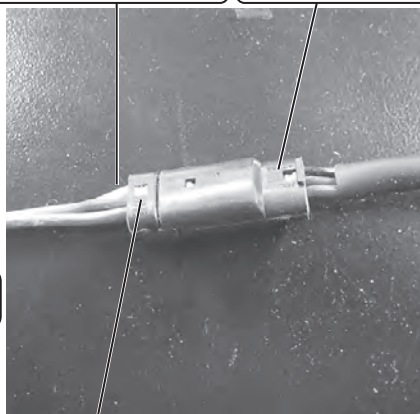


**NOTE: Flow Direction Follows Molded Arrow on Valve.**

Figure 1

Secure White Wire to Chassis Ground

Heater Control Valve Connector



Heater Control Harness Connector

Photo 4

Install a #10 Adel Clamp

Secure Hoses with Tie Wraps

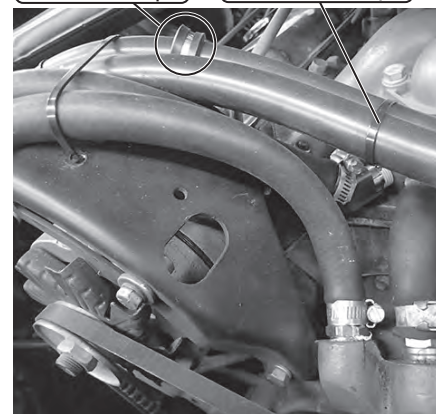


Photo 5

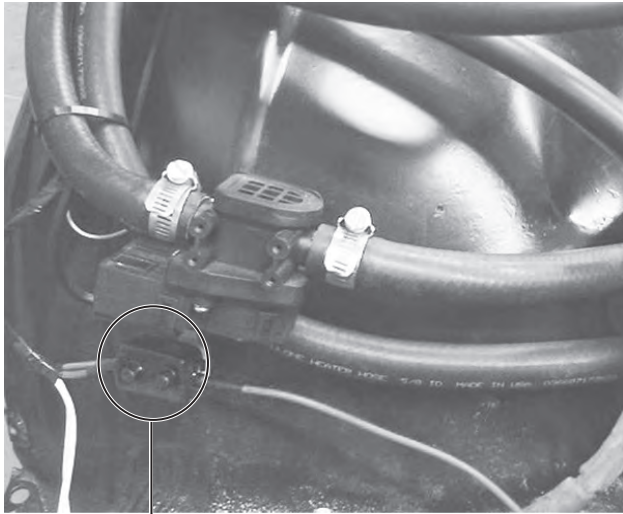




www.vintageair.com

## Wiring Final Steps

1. Reconnect the circuit breaker, and mount it as close as possible to battery (See Photo 1, below).
2. Route the blue lead from the main wiring harness to the safety switch (See Photo 2, below).
3. Connect the compressor lead wire to the safety switch (See Photo 2, below).
4. Wrap the safety switch wiring with flexo sleeve, and secure it with the supplied tie wraps (See Photo 3, below).



Mount Circuit Breaker  
Close to Battery

Photo 1

Connect Wire Leads  
to Safety Switch

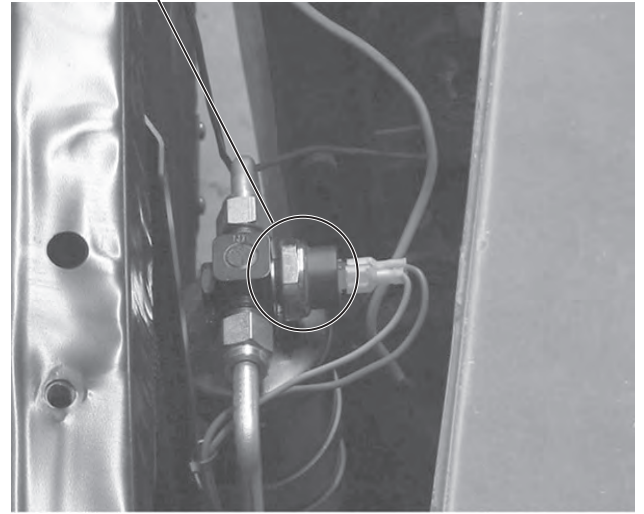
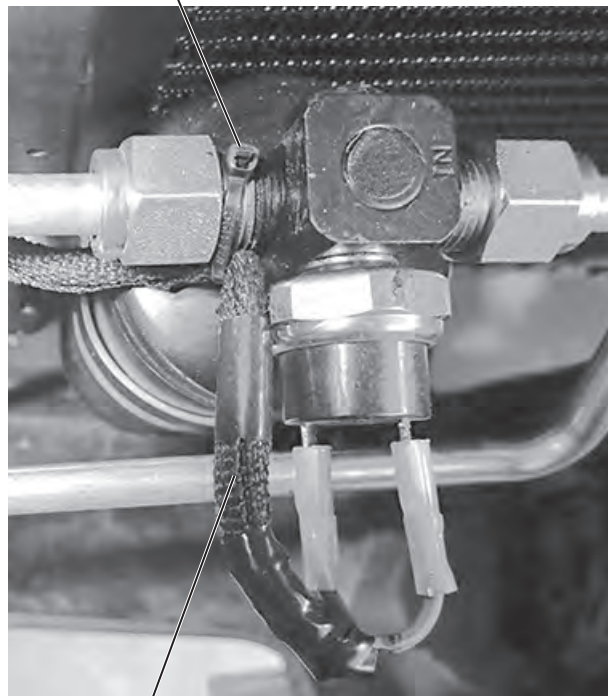


Photo 2

Secure Wiring  
with Tie Wrap



Wrap Safety Switch  
Wiring with Flexo Sleeve

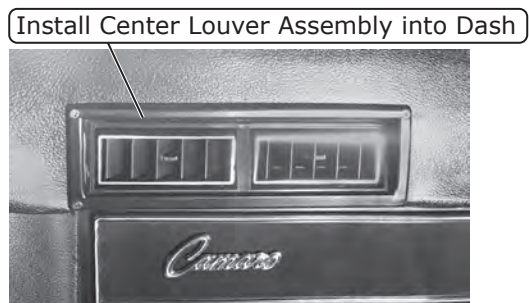
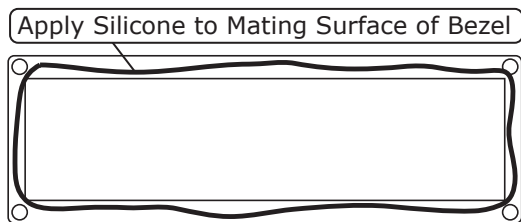
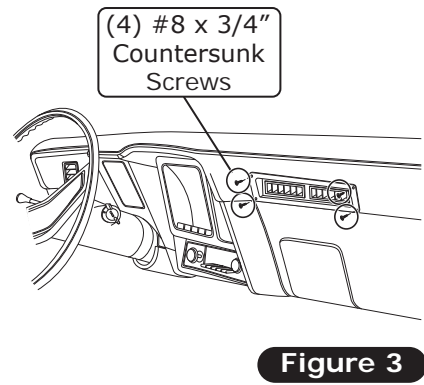
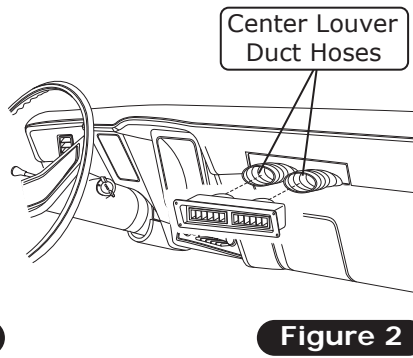
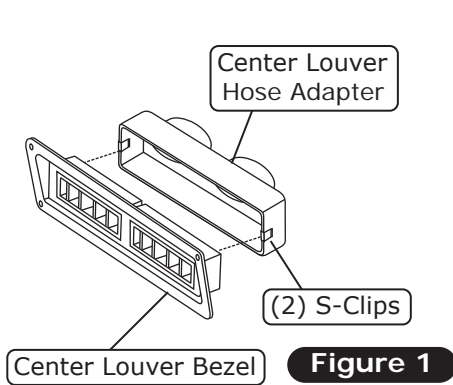
Photo 3



www.vintageair.com

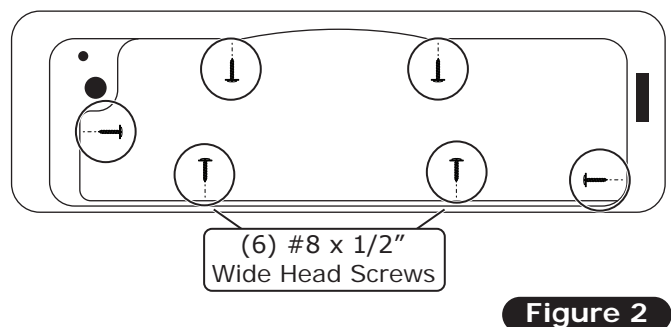
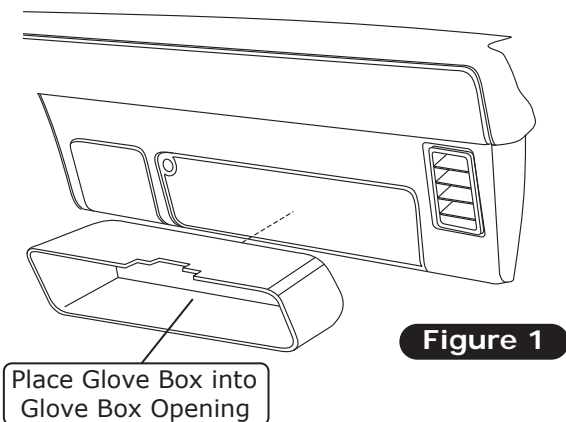
## Center Louver Installation

1. Install the center louver duct hose adapter onto the center louver bezel using (2) s-clips as shown in Figure 1, below.
2. Attach (2) 25" lengths of 2 1/2" duct hose to the center louver as shown in Figure 2, below.
3. Using (4) #8 x 3/4" countersunk screws, secure the center louver assembly to the dash as shown in Figure 3 and Photo 1, below. **NOTE: Vintage Air recommends using a bead of silicone around the mating surface of the center louver bezel before installing it into the dash (See Figure 4, below).**



## Glove Box Installation

1. Place the glove box into the glove box opening in the dash (See Figure 1, below).
2. Using the glove box as a template, mark and drill (6) 1/16" holes into the dash.
3. Secure the glove box using (6) #8 x 1/2" wide head screws (See Figure 2, below).





[www.vintageair.com](http://www.vintageair.com)

## *Final Steps*

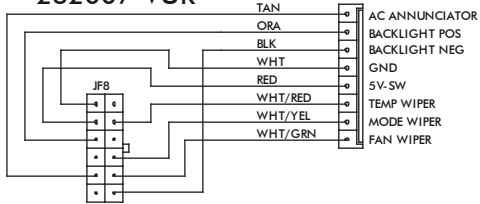
1. Reinstall all previously removed items.
2. Fill the radiator with at least a 50/50 mixture of approved antifreeze and distilled water. It is the owner's responsibility to keep the freeze protection at the proper level for the climate in which the vehicle is operated. Failure to follow antifreeze recommendations will cause the heater core to corrode prematurely and possibly burst in A/C mode and/or freezing weather, voiding your warranty.
3. Double check all fittings, brackets and belts for tightness.
4. Vintage Air recommends that all A/C systems be serviced by a licensed automotive A/C technician.
5. Evacuate the system for a minimum of 45 minutes prior to charging, and perform a leak check prior to servicing.
6. Charge the system to the capacities stated on Page 4 of this instruction manual.
7. See the Operation of Controls procedures on Page 30.



www.vintageair.com

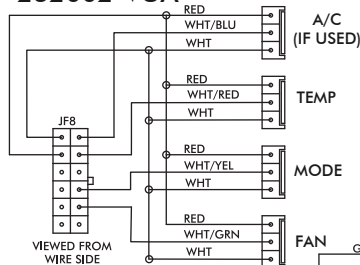
# Wiring Diagram

## 232007-VUR



VIEWED FROM WIRE SIDE

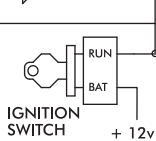
## 232002-VUA



VIEWED FROM WIRE SIDE

## PROGRAM

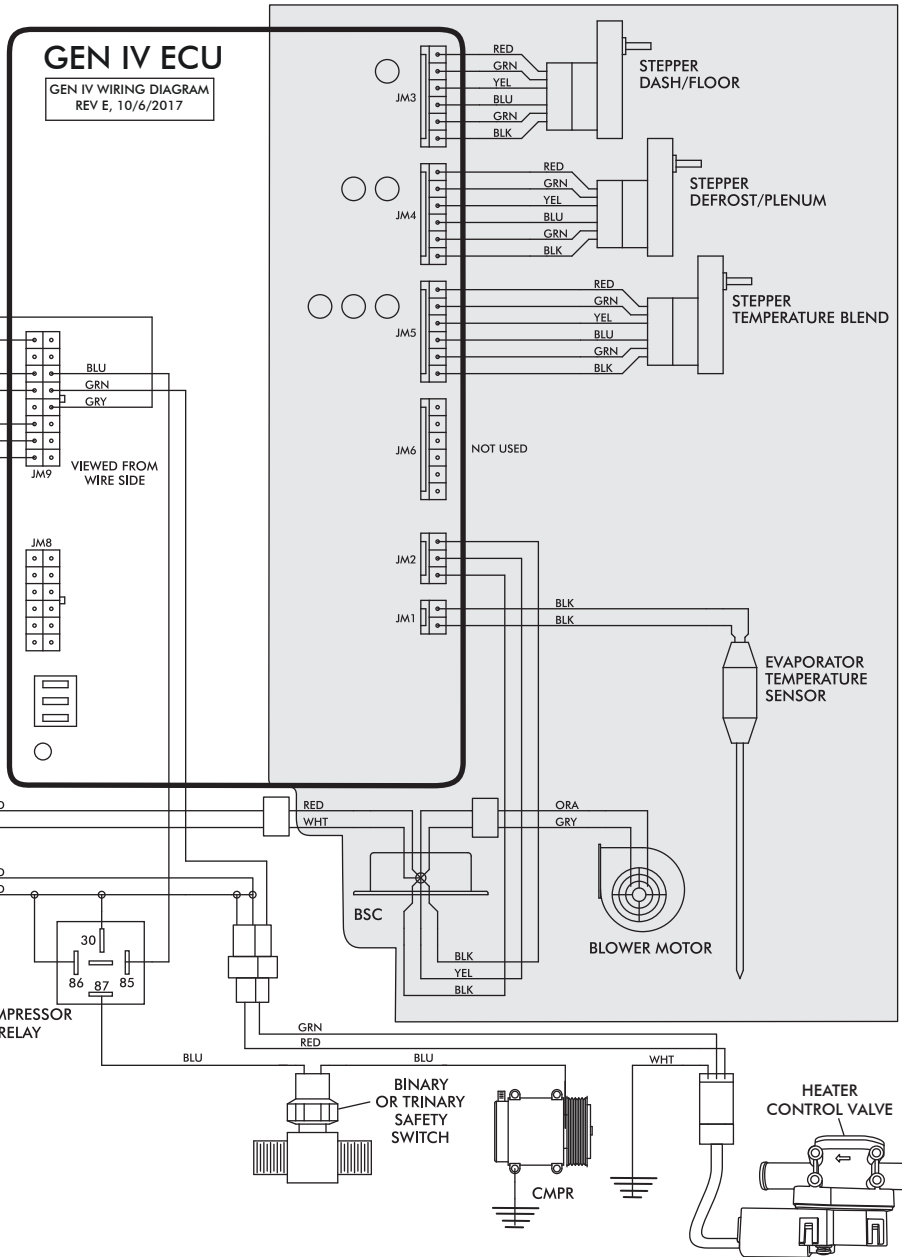
N/A  
\* DASH LAMP (IF USED)  
\*\*\* WIDE OPEN THROTTLE SWITCH (OPTIONAL)



IGNITION SWITCH +12v

## GEN IV ECU

GEN IV WIRING DIAGRAM  
REV E, 10/6/2017



PRE-WIRED

NOTE: = CHASSIS GROUND

\* Dash lamp is used only with type 232007-VUR harness.

\*\* Warning: Always mount circuit breaker as close to the battery as possible. (NOTE: Wire between battery and circuit breaker is unprotected and should be carefully routed to avoid a short circuit).

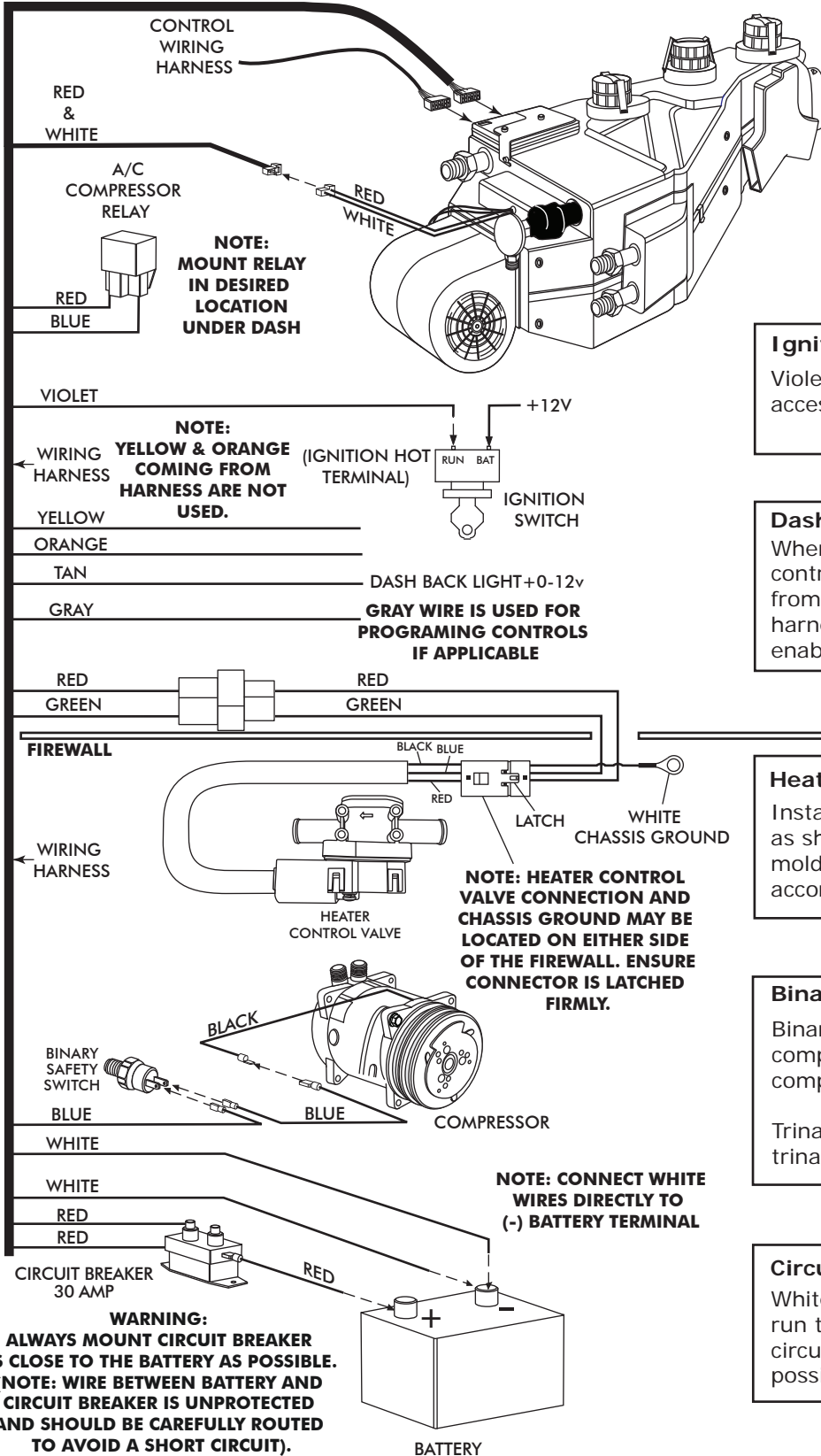
\*\*\* Wide open throttle switch contacts close only at full throttle, which disables A/C compressor.



www.vintageair.com

# Gen IV Wiring Connection Instruction

WIRING HARNESS



**Ignition Switch:**  
Violet 12V ignition switch source (key on accessory) position must be switched.

**Dash Light:**  
When using a Vintage Air supplied control panel, connect the tan wire from the Gen IV evaporator wiring harness to the factory dash lights to enable panel backlighting.

**Heater Control Valve:**  
Install with servo motor facing down, as shown. Note flow direction arrow molded into valve body and install accordingly.

**Binary/Trinary & Compressor:**  
Binary: Connect as shown (typical compressor wiring). Be sure compressor body is grounded.  
Trinary Switch: Connect according to trinary switch wiring diagram.

**Circuit Breaker/Battery:**  
White **must** run to (-) battery. Red may run to (+) battery or starter. Mount circuit breaker as close to battery as possible.

**WARNING:**  
ALWAYS MOUNT CIRCUIT BREAKER AS CLOSE TO THE BATTERY AS POSSIBLE. (NOTE: WIRE BETWEEN BATTERY AND CIRCUIT BREAKER IS UNPROTECTED AND SHOULD BE CAREFULLY ROUTED TO AVOID A SHORT CIRCUIT).



www.vintageair.com

## Operation of Controls

On Gen IV systems with three lever/knob controls, the temperature control toggles between heat and A/C operations. To activate A/C, move the temperature lever/knob all the way to cold and then back it off to the desired vent temperature. For heat operation, move the temperature lever/knob all the way to hot and then adjust to the desired vent temperature. The blower will momentarily change speed, each time you toggle between operations, to indicate the change. **NOTE: For proper control panel function, refer to control panel instructions for calibration procedure.**

### Blower Speed

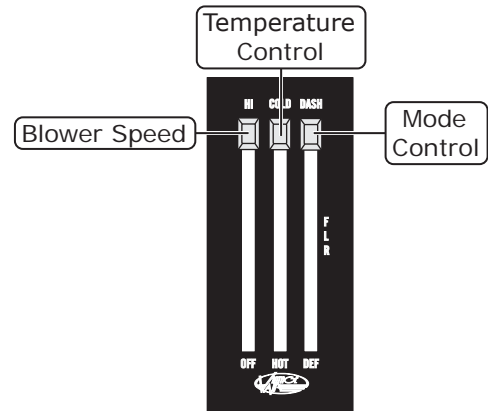
This lever controls blower speed, from OFF to HI.

### Mode Control

This lever controls the mode positions, from DASH to FLOOR to DEFROST, with a blend in between.

### Temperature Control

This lever controls the temperature, from HOT to COLD.



### *A/C Operation*

### Blower Speed

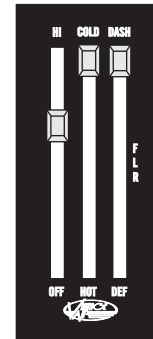
Adjust to desired speed.

### Mode Control

Adjust to desired mode position (DASH position recommended).

### Temperature Control

For A/C operation, adjust to coldest position to engage compressor (Adjust between HOT and COLD to reach desired temperature).



### *Heat Operation*

### Blower Speed

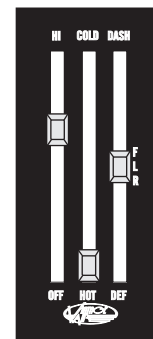
Adjust to desired speed.

### Mode Control

Adjust to desired mode position (FLOOR position recommended).

### Temperature Control

For maximum heating, adjust to hottest position (Adjust between HOT and COLD to reach desired temperature).



### *Defrost/De-fog Operation*

### Blower Speed

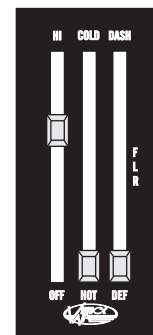
Adjust to desired speed.

### Temperature Control

Adjust to desired temperature.

### Mode Control

Adjust to DEFROST position for maximum defrost, or between FLOOR and DEFROST positions for a bi-level blend (Compressor is automatically engaged).





www.vintageair.com

# Troubleshooting Guide

Symptom	Condition	Checks	Actions	Notes
1a. Blower stays on high speed when ignition is on.	No other functions work.	Check for damaged pins or wires in control head plug.	Verify that all pins are inserted into plug. Ensure that no pins are bent or damaged in ECU.	Loss of ground on this wire renders control head inoperable.  See blower switch check procedure.
		Check for damaged ground wire (white) in control head harness.	Verify continuity to chassis ground with white control head wire at various points.	
		Check for damaged blower switch or potentiometer and associated wiring.		
		All other functions work.		
1b. Blower stays on high speed when ignition is on or off.		Unplug 3-wire BSC control connector from ECU. If blower shuts off, ECU is either improperly wired or damaged.	Be sure the small, 20 GA white ground wire is connected to the battery ground post. If it is, replace the ECU.	No other part replacements should be necessary.
		Unplug 3-wire BSC control connector from ECU. If blower stays running, BSC is either improperly wired or damaged.	Check to ensure that no BSC wiring is damaged or shorted to vehicle ground. The BSC operates the blower by ground side pulse width modulation switching. The positive wire to the blower will always be hot. If the "ground" side of the blower is shorted to chassis ground, the blower will run on HI.	
		Replace BSC (This will require removal of evaporator from vehicle).		
2. Compressor will not turn on (All other functions work).	System is not charged.	System must be charged for compressor to engage.	Charge system or bypass pressure switch.	<b>Danger: Never bypass safety switch with engine running. Serious injury can result.</b>  To check for proper pot function, check voltage at white/blue wire. Voltage should be between 0V and 5V, and will vary with pot lever position.  Disconnected or faulty thermistor will cause compressor to be disabled.  Red wire at A/C pot should have approximately 5V with ignition on. White wire will have continuity to chassis ground. White/Blue wire should vary between 0V and 5V when lever is moved up or down.
		Check for faulty A/C potentiometer or associated wiring (not applicable to 3-pot controls).	Check continuity to ground on white control head wire. Check for 5V on red control head wire.	
		Check for disconnected or faulty thermistor.	Check 2-pin connector at ECU housing.	
		Check for faulty A/C potentiometer or associated wiring.	Repair or replace pot/control wiring.	
		Check for faulty A/C relay.	Replace relay.	
3. Compressor will not turn off (All other functions work).	System is charged.	Check for faulty A/C potentiometer or associated wiring.	Repair or replace pot/control wiring.	Red wire at A/C pot should have approximately 5V with ignition on. White wire will have continuity to chassis ground. White/Blue wire should vary between 0V and 5V when lever is moved up or down.
		Check for faulty A/C relay.	Replace relay.	



www.vintageair.com

# Troubleshooting Guide (Cont.)

Symptom	Condition	Checks	Actions	Notes
4. System will not turn on, or runs intermittently.	Works when engine is not running; shuts off when engine is started (typically early Gen IV, but possible on all versions).	Noise interference from either ignition or alternator.	Install capacitors on ignition coil and alternator. Ensure good ground at all points. Relocate coil and associated wiring away from ECU and ECU wiring. Check for burned or loose plug wires.	Ignition noise (radiated or conducted) will cause the system to shut down due to high voltage spikes. If this is suspected, check with a quality oscilloscope. Spikes greater than 16V will shut down the ECU. Install a radio capacitor at the positive post of the ignition coil (see radio capacitor installation bulletin). A faulty alternator or worn out battery can also result in this condition.
	Will not turn on under any conditions.	Verify connections on power lead, ignition lead, and both white ground wires.	Check for positive power at heater valve green wire and blower red wire. Check for ground on control head white wire.	
		Verify battery voltage is greater than 10 volts and less than 16.	Verify proper meter function by checking the condition of a known good battery.	
		Check for damaged mode switch or potentiometer and associated wiring.		
5. Loss of mode door function.	No mode change at all.	Check for obstructed or binding mode doors.		Typically caused by evaporator housing installed in a bind in the vehicle. Be sure all mounting locations line up and don't have to be forced into position.
	Partial function of mode doors.	Check for damaged stepper motor or wiring.		
6. Blower turns on and off rapidly.	Battery voltage is at least 12V.	Check for at least 12V at circuit breaker.	Ensure all system grounds and power connections are clean and tight.	System shuts off blower at 10V. Poor connections or weak battery can cause shutdown at up to 11V.
	Battery voltage is less than 12V.	Check for faulty battery or alternator.	Charge battery.	
7. Erratic functions of blower, mode, temp, etc.		Check for damaged switch or pot and associated wiring.	Repair or replace.	
		This is an indicator that the system has been reset. Be sure the red power wire is on the battery post, and not on a switched source. Also, if the system is pulled below 7V for even a split second, the system will reset.	Run red power wire directly to battery.	







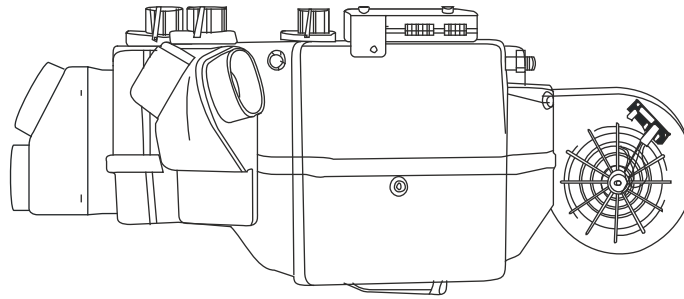
www.vintageair.com

# Packing List: Evaporator Kit (561191)

No.	Qty.	Part No.	Description
1.	1	744004-VUE	Gen IV Evaporator Sub Case
2.	1	781191	Accessory Kit

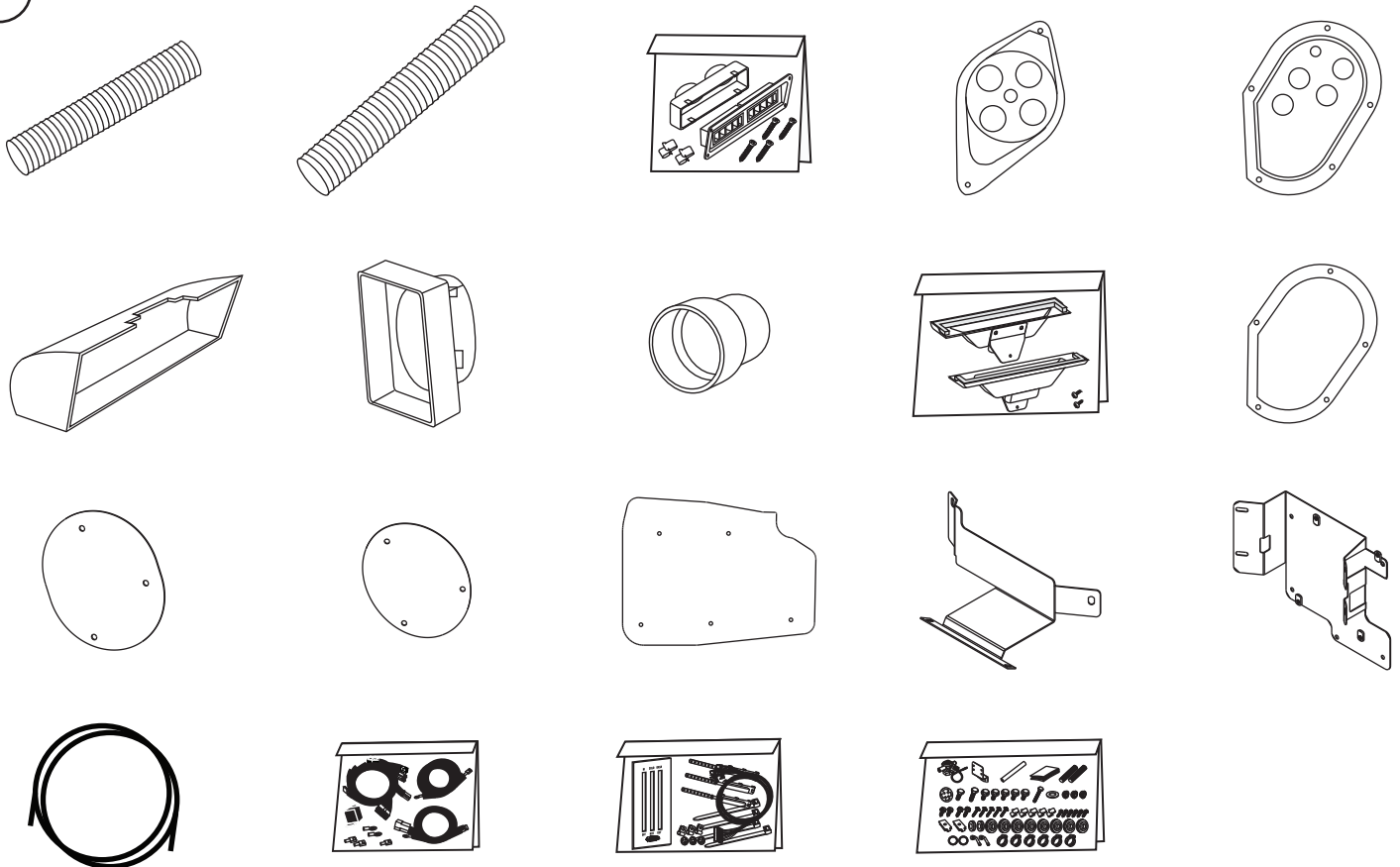
Checked By: \_\_\_\_\_  
Packed By: \_\_\_\_\_  
Date: \_\_\_\_\_

1



Gen IV Evaporator  
Sub Case  
744004-VUE

2



Accessory Kit  
781191

NOTE: Images may not depict actual parts and quantities.  
Refer to packing list for actual parts and quantities.