

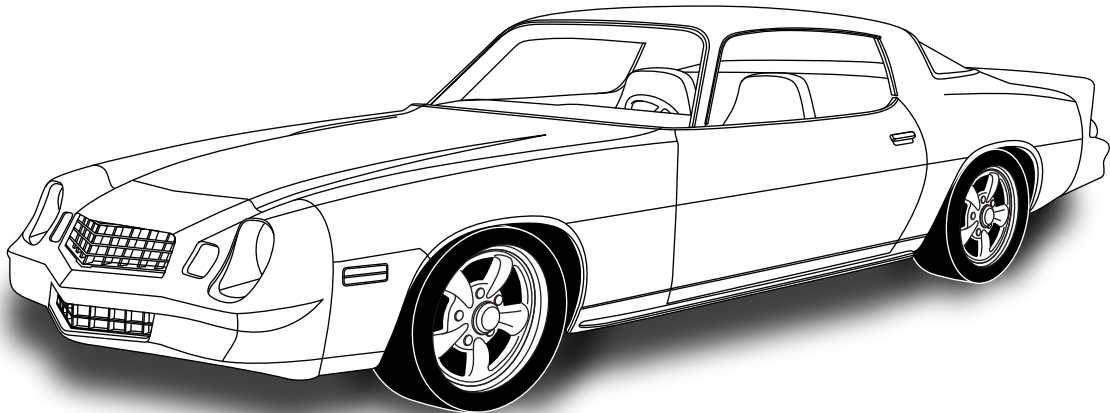

an ISO 9001:2015 Registered Company

1979-81 Chevrolet Camaro

without Factory Air
Evaporator Kit
(561180)



18865 Goll St. San Antonio, TX 78266

Phone: 800-862-6658

Sales: sales@vintageair.com

Tech Support: tech@vintageair.com

www.vintageair.com



www.vintageair.com

Table of Contents

Cover.....	1
Table of Contents.....	2
Packing List/Parts Disclaimer.....	3
Information Page.....	4
Wiring Notice.....	5
Engine Compartment Disassembly, Condenser Assembly and Installation, Compressor and Brackets, Pulleys.....	6
Passenger Compartment Disassembly.....	7
Passenger Side Kick Panel Modification.....	8
Defrost Duct/Fresh Air Cover Installation, Hose Adapter Installation.....	9
Fresh Air Cap Installation, Kick Panel Fresh Air Cap Installation.....	10
Firewall Cover Installation, Evaporator Assembly Preparation.....	11
Evaporator Assembly Preparation (Cont.).....	12
Evaporator Installation.....	13
Center Louver Installation, Drain Hose Installation.....	14
Lubricating O-rings, A/C Hose Installation.....	15
Heater Hose & Heater Control Valve Installation, A/C and Heater Hose Routing.....	16
Final Steps, Glove Box Installation.....	17
Control Panel & Duct Hose Routing.....	18
Wiring Diagram.....	19
Gen IV Wiring Connection Instruction.....	20
Operation of Controls.....	21
Troubleshooting Guide.....	22
Troubleshooting Guide (Cont.).....	23
Kick Panel Modification Template.....	24
Glove Box Light Template.....	25
Packing List.....	26



www.vintageair.com

Packing List: Evaporator Kit (561180)

No.	Qty.	Part No.	Description
1.	1	744004-VUE	Gen IV Evaporator Sub Case
2.	1	781173	Accessory Kit

**** Before beginning installation, open all packages and check contents of shipment. Please report any shortages directly to Vintage Air within 15 days. After 15 days, Vintage Air will not be responsible for missing or damaged items.**

1

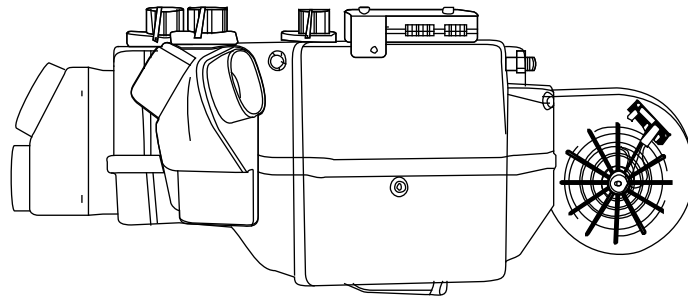

Gen IV Evaporator
Sub Case
744004-VUE

2

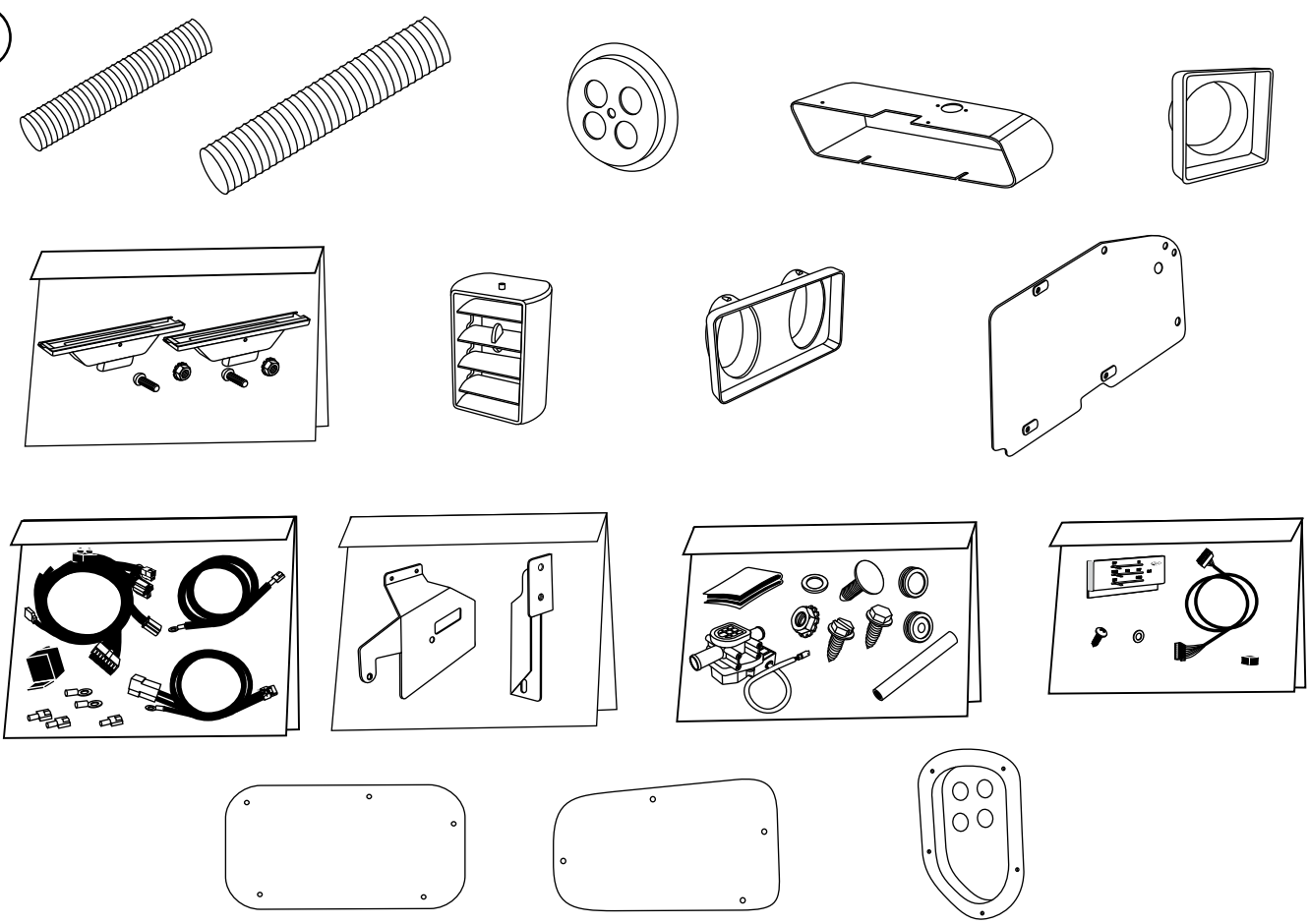

Accessory Kit
781173

NOTE: Images may not depict actual parts and quantities. Refer to packing list for actual parts and quantities.



www.vintageair.com

Important Notice—Please Read

For Maximum System Performance, Vintage Air Recommends the Following:

NOTE: Vintage Air systems are designed to operate with R134a refrigerant only. Use of any other refrigerant could damage your A/C system and/or vehicle, and possibly cause a fire, in addition to potentially voiding the warranties of the A/C system and its components.

Refrigerant Capacities:

Vintage Air System: 1.8 lbs. (28.8 oz.) or 816 grams of **R134a**, charged by weight with a quality charging station or scale. **NOTE: Use of the proper type and amount of refrigerant is critical to system operation and performance.**

Other Systems: Consult manufacturer's guidelines.

Lubricant Capacities:

New Vintage Air-Supplied Sanden Compressor: No additional oil needed (Compressor is shipped with proper oil charge).

All Other Compressors: Consult manufacturer (Some compressors are shipped dry and will need oil added).

Safety Switches

Your Vintage Air system is equipped with a binary pressure safety switch. A binary switch disengages the compressor clutch in cases of extreme low pressure conditions (refrigerant loss) or excessively high head pressure (406 PSI) to prevent compressor damage or hose rupture. A trinary switch combines Hi/Lo pressure protection with an electric fan operation signal at 254 PSI, and should be substituted for use with electric fans. Compressor safety switches are extremely important since an A/C system relies on refrigerant to circulate lubricant.

Service Info:

Protect Your Investment: Prior to assembly, it is critical that the compressor, evaporator, A/C hoses and fittings, hardlines, condenser and receiver/drier remain capped. Removing caps prior to assembly will allow moisture, insects and debris into the components, possibly leading to reduced performance and/or premature failure of your A/C system. This is especially important with the receiver/drier.

Additionally, when caps are removed for assembly, **BE CAREFUL!** Some components are shipped under pressure with dry nitrogen.

Evacuate the System for 35-45 Minutes: Ensure that system components (Drier, compressor, evaporator and condenser) are at a temperature of at least 85°F. On a cool day, the components can be heated with a heat gun **or** by running the engine with the heater on before evacuating. Leak check and charge to specifications.

Bolts Passing Through Cowl and/or Firewall:

To ensure a watertight seal between the passenger compartment and the vehicle exterior, for all bolts passing through the cowl and/or firewall, Vintage Air recommends coating the threads with silicone prior to installation.

Heater Hose (not included with this kit):

Heater hose may be purchased from Vintage Air (Part#31800-VUD) or your local parts retailer. Routing and required length will vary based on installer preference.



www.vintageair.com

Important Wiring Notice—Please Read

Some vehicles may have had some or all of their radio interference capacitors removed. There should be a capacitor found at each of the following locations:

- 1. On the positive terminal of the ignition coil.**
- 2. If there is a generator, on the armature terminal of the generator.**
- 3. If there is a generator, on the battery terminal of the voltage regulator.**

Most alternators have a capacitor installed internally to eliminate what is called “whining” as the engine is revved. If whining is heard in the radio, or just to be extra cautious, a radio interference capacitor can be added to the battery terminal of the alternator.

It is also important that the battery lead is in good shape and that the ground leads are not compromised. There should be a heavy ground from the battery to the engine block, and additional grounds to the body and chassis.

If these precautions are not observed, it is possible for voltage spikes to be present on the battery leads. These spikes come from ignition systems and charging systems, and from switching some of the vehicle’s other systems on and off. Modern computer-operated equipment can be sensitive to voltage spikes on the power leads, which can cause unexpected resets, strange behavior and/or permanent damage.

Vintage Air strives to harden our products against these types of electrical noise, but there is a point where a vehicle’s electrical system can be degraded so much that nothing can help.

Radio interference capacitors should be available at most auto and truck parts suppliers. They typically are cylindrical in shape, a little over an inch long and a little over a half-inch in diameter, and they have a single lead coming from one end of the cylinder with a terminal on the end of the wire, as well as a mounting clip which is screwed into a good ground on the vehicle. The specific value of the capacitance is not too significant in comparison to ignition capacitors that are matched with the coil to reduce pitting of the points.

- Care must be taken, when installing the compressor lead, not to short it to ground. The compressor lead must not be connected to a condenser fan or to any other auxiliary device. Shorting to ground or connecting to a condenser fan or any other auxiliary device may damage wiring or the compressor relay, and/or cause a malfunction.
- When installing ground leads on Gen IV systems, the blower control ground and ECU ground must be connected directly to the negative battery post.
- For proper system operation, the heater control valve must be connected to the ECU.



www.vintageair.com

Engine Compartment Disassembly

NOTE: Before starting the installation, check the function of the vehicle (horn, lights, etc.) for proper operation, and study the instructions, illustrations, & diagrams.

Perform the Following:

1. Disconnect the battery.
2. Remove the battery and the battery tray (retain) (See Figure 1, below).
3. Drain the radiator.
4. Remove the hood latch and hood latch support assemblies (retain) (See Figure 1, below).
5. Remove the OEM blower motor assembly (discard). **NOTE: To remove the blower motor assembly (under hood) and the air distribution system (under dash), remove the inner fender panel (See Figure 1, below).**
6. Remove OEM heater hoses (discard).
7. Remove OEM heater wiring/vacuum harness molded grommet (See Figure 1, below).

Condenser Assembly and Installation

1. Refer to separate instructions included with the condenser kit to install the condenser.
2. Binary switch installation (Refer to condenser instructions).

Compressor and Brackets

1. Refer to separate instructions included with the bracket kit to install the compressor bracket.

Pulleys

1. In most instances, the belt lengths will remain the same.

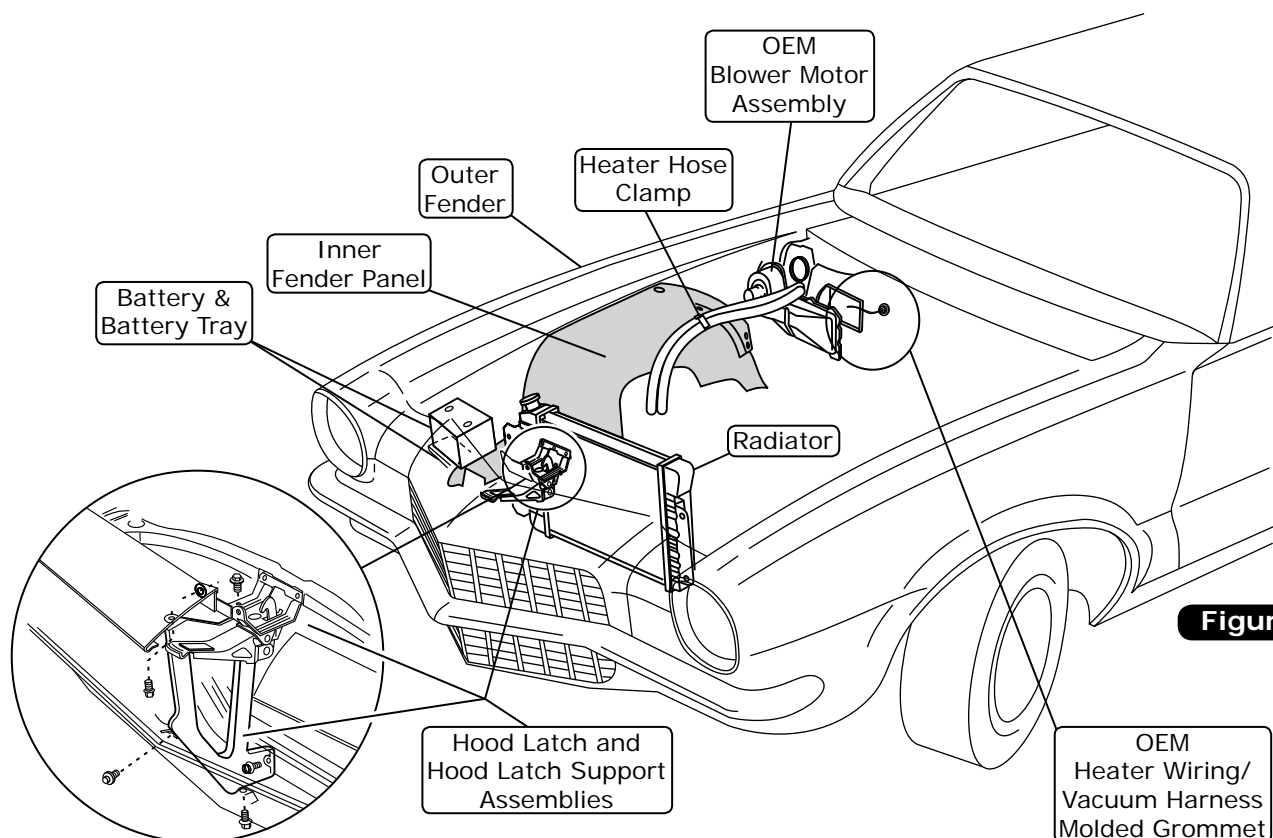

Figure 1



www.vintageair.com

Passenger Compartment Disassembly

NOTE: Dashboard removal is not required to install the evaporator. Vintage Air recommends using the factory service manual for disassembly and reassembly of dashboard components.

Perform the Following:

1. Remove the glove box door (See Figure 3, below).
2. Remove the glove box (discard) (See Figure 2, below). Retain the screws.
3. Remove the heater assembly and all related ducting (discard, but retain screws) (See Figure 3, below).
4. Remove the driver/passenger side louver outlets (retain). **NOTE: The instrument panel must be removed to get to the left outlet and the control panel (See Figure 3, below).**
5. Remove the control panel assembly (discard) (See Figure 3, below). **NOTE: Refer to the control panel conversion kit instructions for installation of the controls.**
6. Remove the passenger side kick panel (retain) (See Figure 3, below).
7. Disconnect the passenger side fresh air cable from the panel (See Figure 3, below).
8. Disconnect the driver/passenger cable astro ventilation ducting (discard) (See Figure 3, below).
9. Remove the OEM defrost duct assemblies (discard).

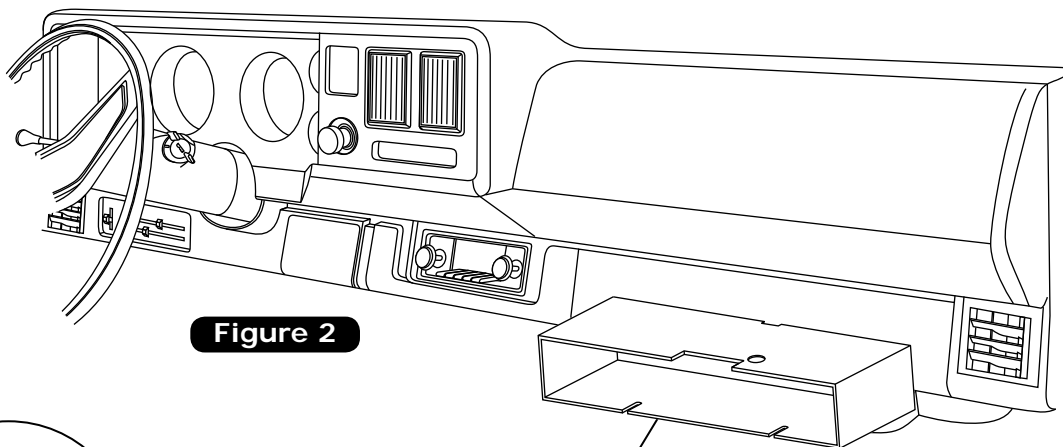

Figure 2

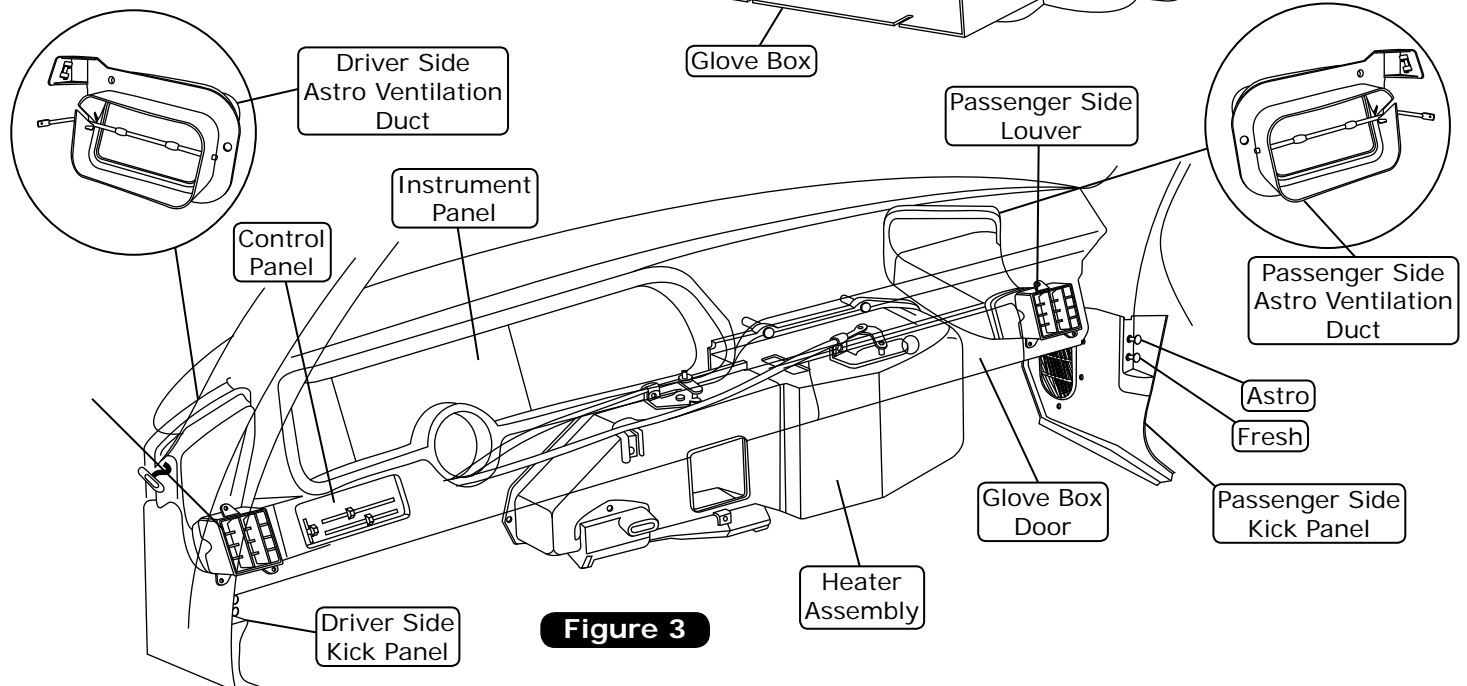

Figure 3



www.vintageair.com

Passenger Side Kick Panel Modification

1. Remove the kick panel by removing (5) OEM screws. Disconnect the fresh air door from the lever housing (See Figure 4, below).
2. Cut the kick panel grille using the template provided on Page 24 (See Figure 4a, below).
3. Enlarge the OEM lever housing holes to 1/2" (See Figure 4a, below).
4. Install (2) 1/2" plastic plugs into the OEM lever housing holes (See Figure 4a, below).

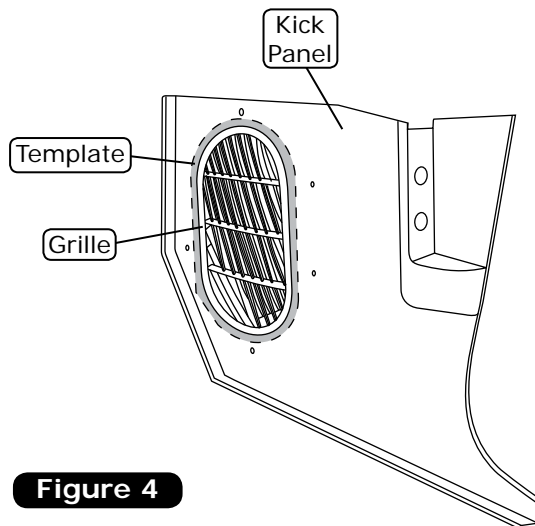
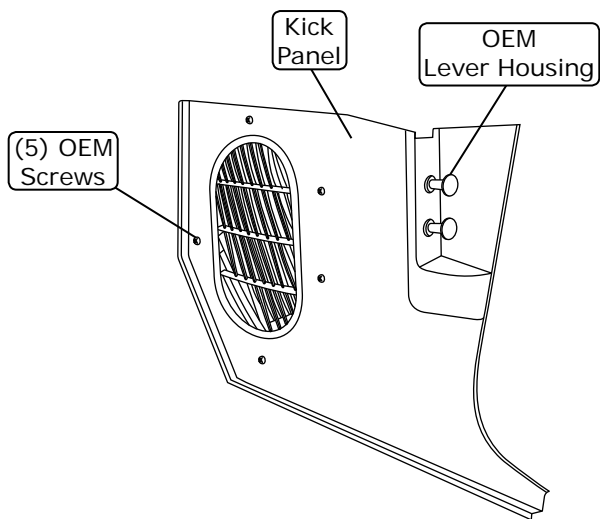

Figure 4

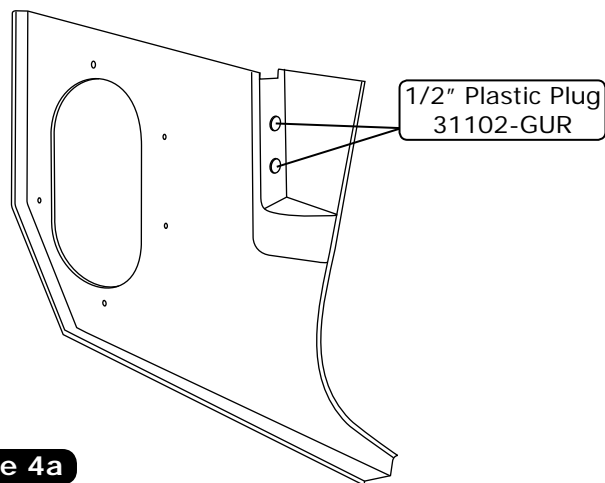
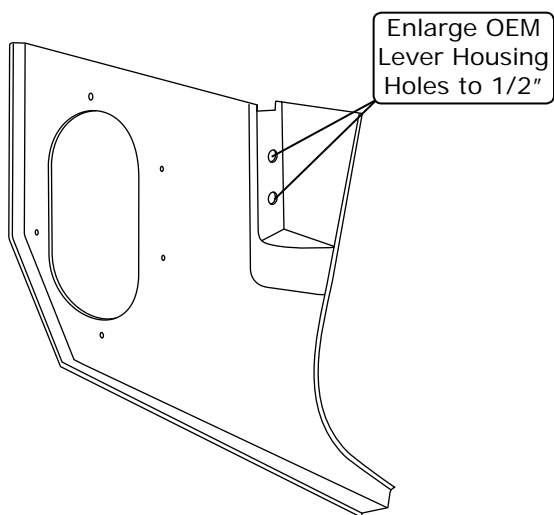

Figure 4a



www.vintageair.com

Defrost Duct/Fresh Air Cover Installation

1. Install the defrost ducts under the dash on the OEM defrost duct mounting flange as shown in Figure 5, below. Secure using a 10-24 x 3/8" pan head screw and a 10-24 nut with star washer.
2. Apply a 1/4" bead of silicone around the mating surface of the driver and passenger side fresh air covers as shown in Figure 5a, below.
3. Install the driver and passenger side fresh air covers, and secure them using the OEM screws (See Figure 5, below).

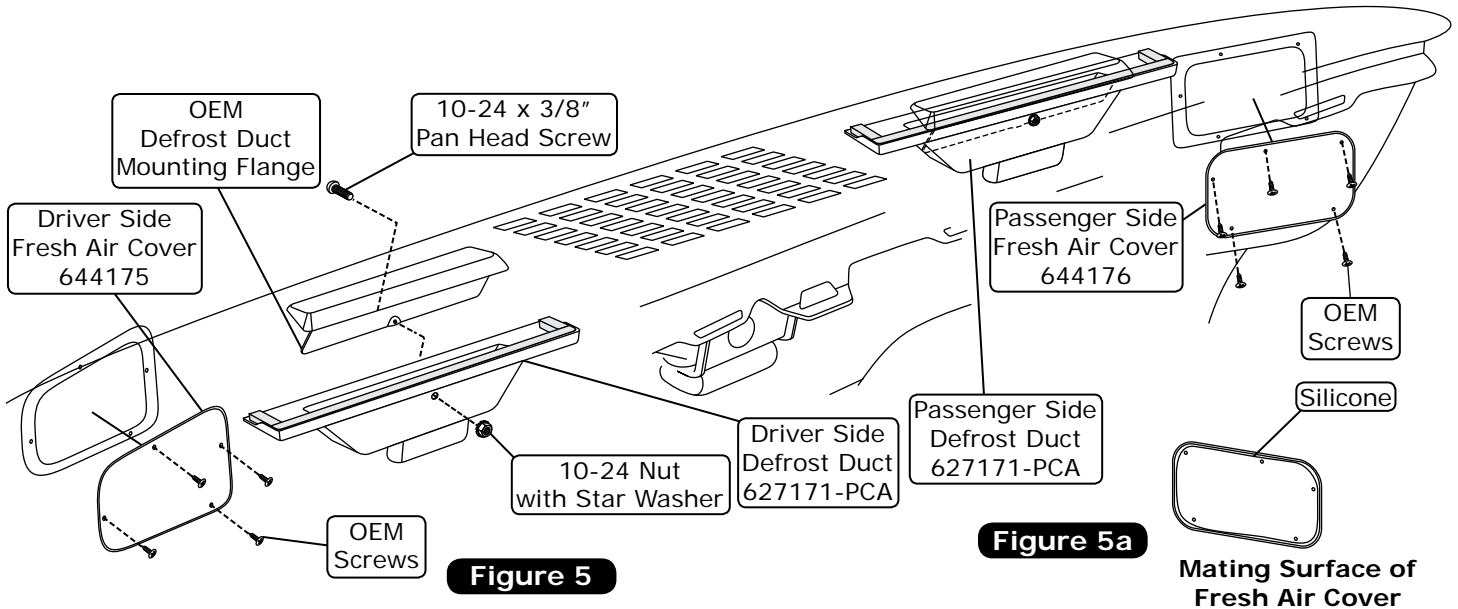

Hose Adapter Installation

1. Install (2) S-clips onto each hose adapter as shown in Figure 6, below.
2. Install the driver and passenger side hose adapters onto the OEM louvers (See Figure 6, below).

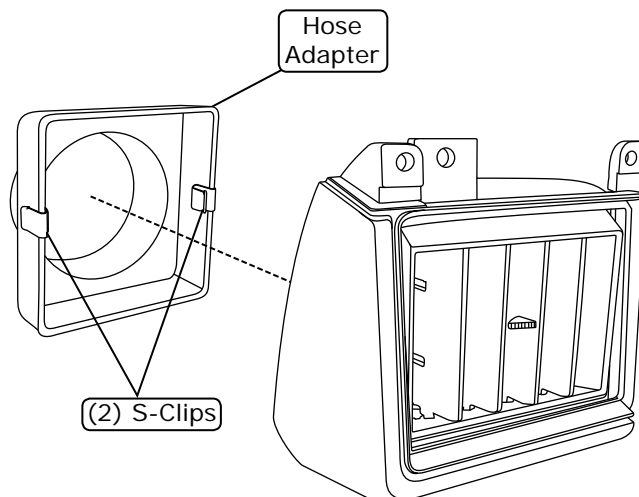



www.vintageair.com

Fresh Air Cap Installation

NOTE: To ensure a watertight seal between the passenger compartment and the vehicle exterior, for all bolts passing through the firewall, Vintage Air recommends coating the threads with silicone prior to installation.

1. Install (4) grommets into the fresh air cap (See Figure 7, below).
2. Apply a 1/4" bead of silicone around the mating surface of the fresh air cap as shown in Figure 7, below.
3. Attach the fresh air cap to the firewall using the fresh air cap bracket, a 1/4-20 x 1 1/2" bolt, and a 1/4" washer (See Figure 7, below). **NOTE: The fresh air cap installs on the engine side of the firewall.**
4. Install a 1 1/4" plug into the firewall (See Figure 7, below).

Figure 7

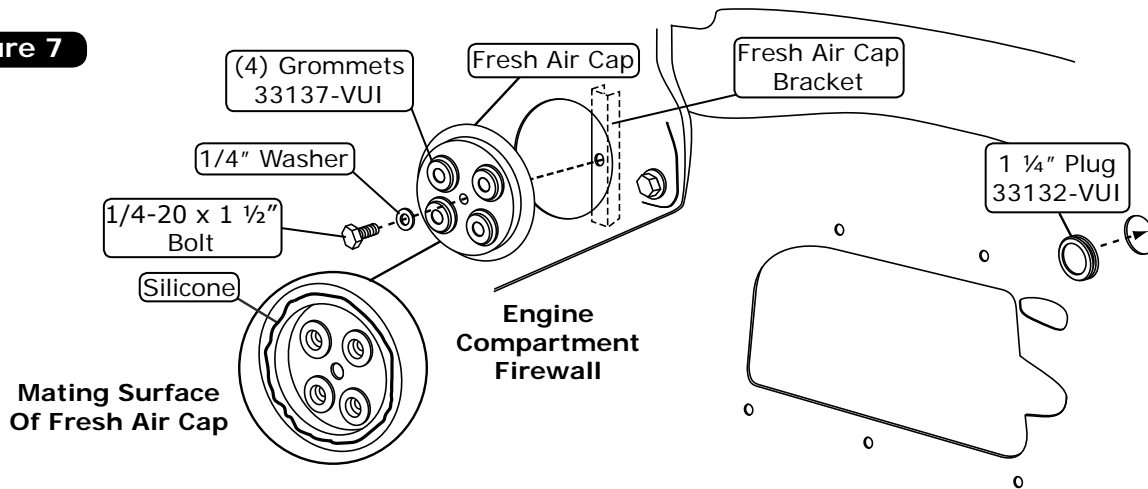

Kick Panel Fresh Air Cap Installation

1. Install (4) grommets into the kick panel fresh air cap (See Figure 8a, below).
2. Route the A/C and heater hoses through the fresh air cap and the kick panel fresh air cap as shown in Figures 8 and 8b, below.
3. Apply 1/4" bead of silicone around the mating surface of the kick panel fresh air cap as shown in Figure 8a, below.
4. Secure the kick panel fresh air cap using the OEM screws as shown in Figure 8b, below.

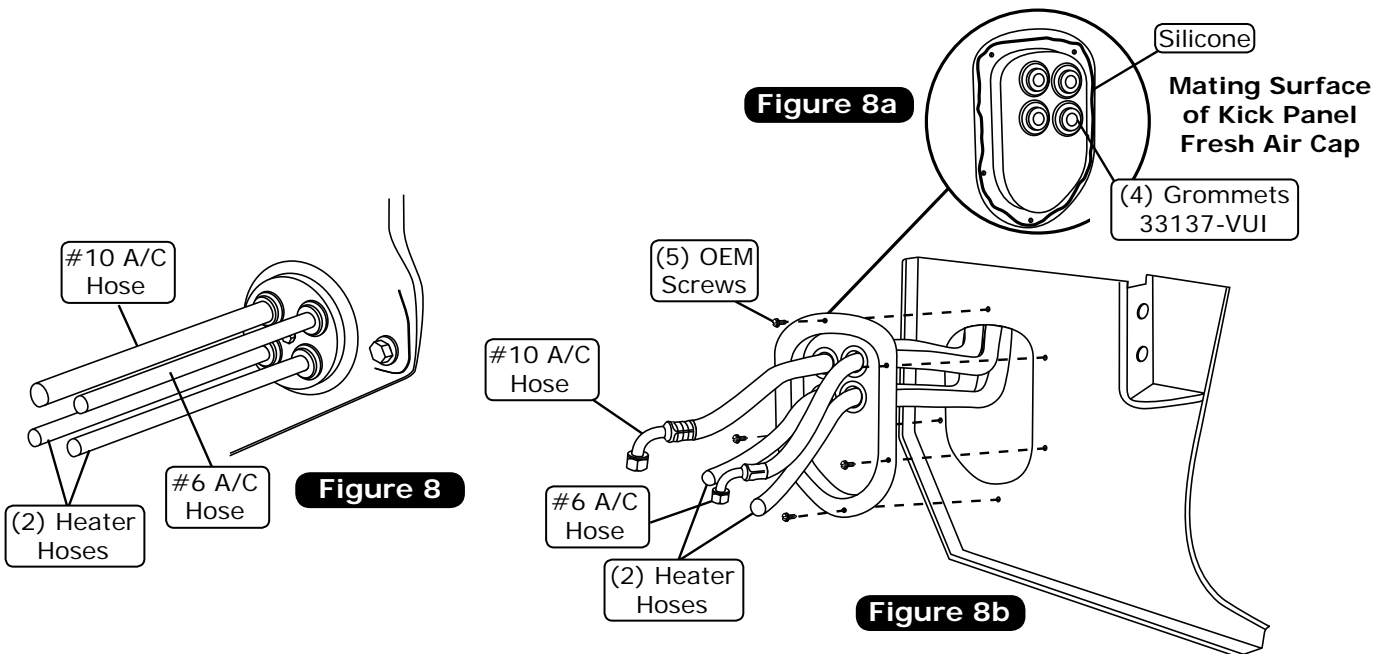



www.vintageair.com

Firewall Cover Installation

NOTE: To ensure a watertight seal between the passenger compartment and the vehicle exterior, for all bolts passing through the firewall, Vintage Air recommends coating the threads with silicone prior to installation.

1. Enlarge (5) OEM firewall holes to 5/16" (See Figure 9, below).
2. Apply a 1/4" bead of silicone around the mating surface of the firewall cover as shown in Figure 9, below.
3. From the passenger compartment, install the firewall cover onto the firewall (See Figure 9, below). From the engine compartment, secure the firewall cover to the firewall using (4) 1/4-20 x 1" hex bolts, (5) flat washers and a 1/4-20 nut with star washer (See Figure 9, below).

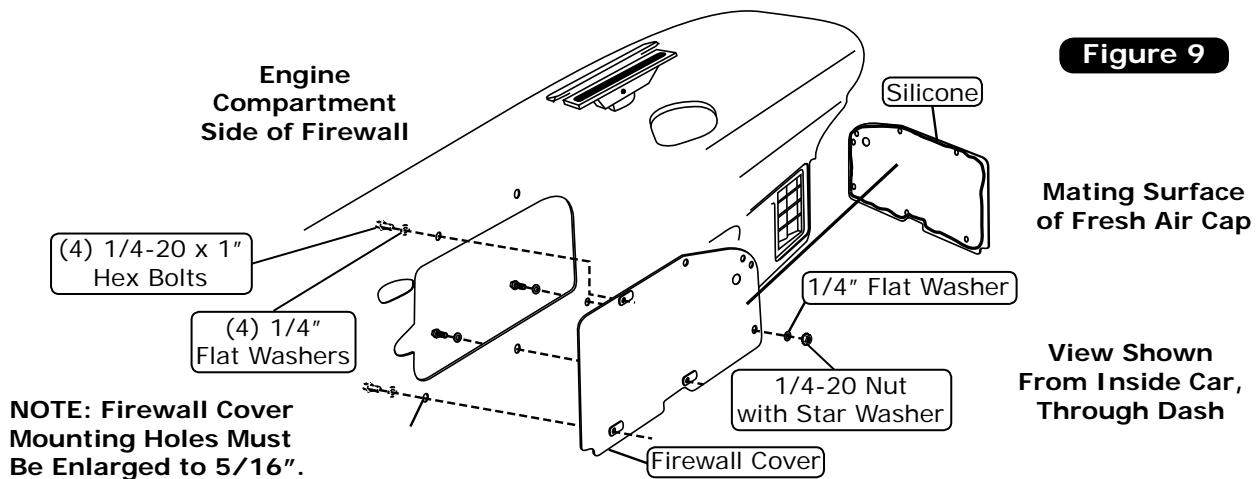

Evaporator Assembly Preparation

1. On a workbench, install the evaporator rear bracket using (2) 1/4-20 x 1/2" bolts (supplied on the evaporator sub case) (See Figure 11, Page 12).
2. Install (2) heater fittings (See Figure 11, Page 12) with properly lubricated O-rings (See Figure 15, Page 15).
3. Place the evaporator unit under the dashboard by the passenger side kick panel, and install the heater and A/C hoses (See Figure 12a, Page 13). Use properly lubricated O-rings on the A/C hoses (See Figure 15, Page 15) and (2) hose clamps on the heater hoses. Apply press tape around the #10 fitting as shown in Figure 12a, Page 13.
4. Install the front mounting bracket onto the evaporator using (2) 1/4-20 x 1/2" bolts, and tighten (See Figure 10, below).

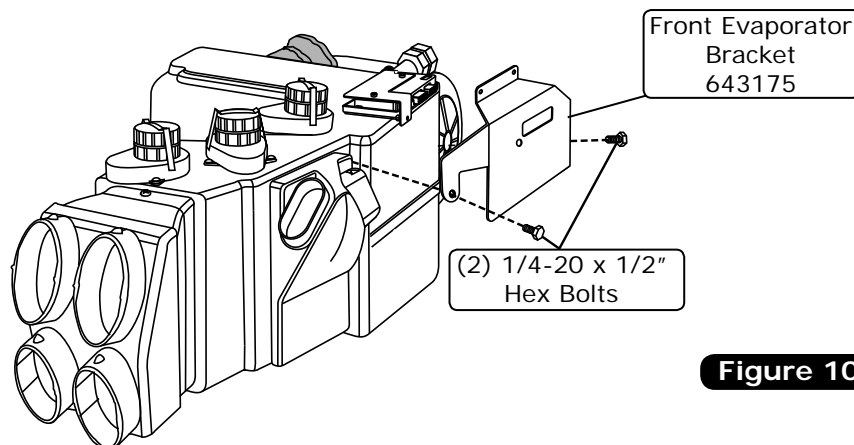



Evaporator Assembly Preparation (Cont.)

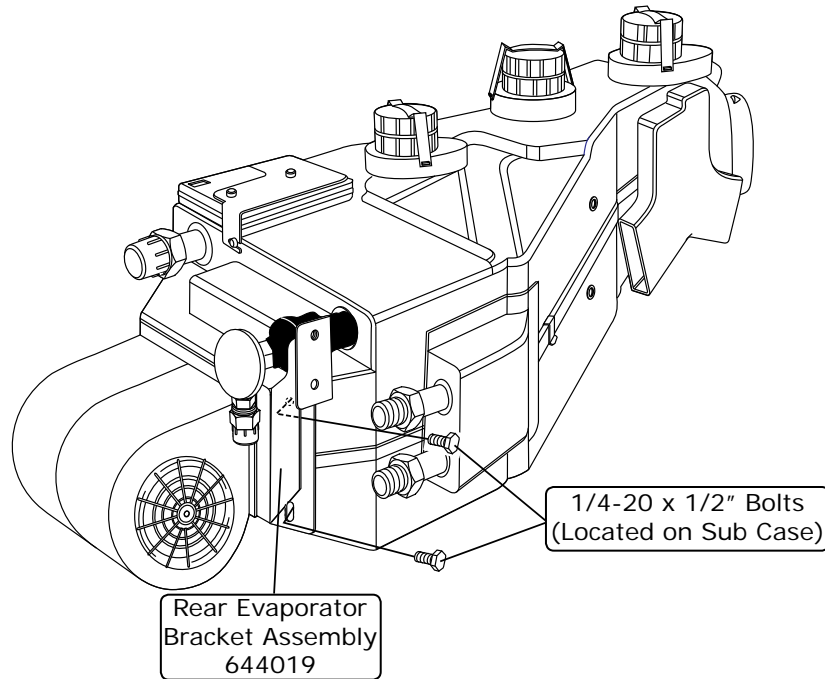
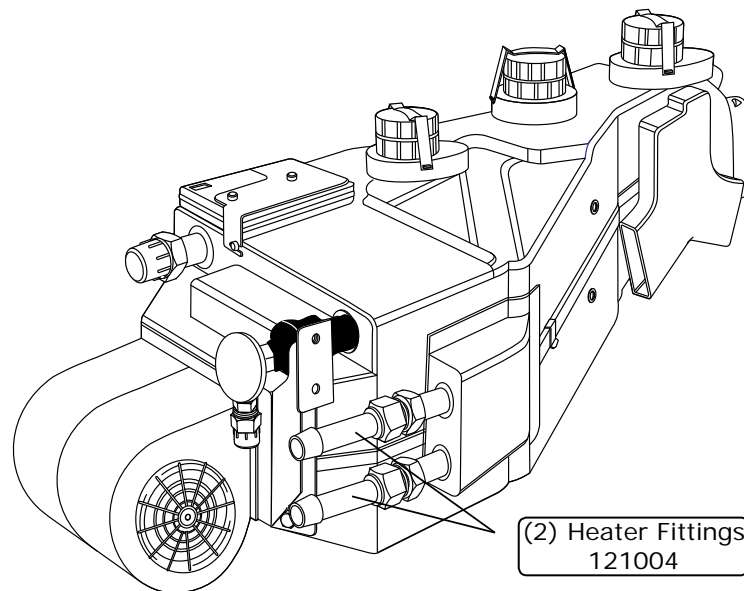

Figure 11





www.vintageair.com

Evaporator Installation

NOTE: To ensure a watertight seal between the passenger compartment and the vehicle exterior, for all bolts passing through the firewall, Vintage Air recommends coating the threads with silicone prior to installation.

1. Lift the evaporator sub case up under the dashboard. Using the top hole of the rear bracket, secure loosely to the firewall using a 1/4-20 x 1" bolt and washer (See Figure 12, below). **NOTE:** When lifting up the evaporator sub case, be careful to prevent damage to the drain outlet located at the bottom of the unit. Feed the hoses into or out of the kick panel fresh air cap as needed while lifting the evaporator sub case into position.
2. Using the front mounting bracket as a template, mark and drill (2) 5/32" holes on the inner cowl (See Figure 12, below). **NOTE:** To ensure proper drainage, it is very important that the evaporator is level, both left-right and fore-aft. Prior to drilling, check for level on the flat portions of the case around the drain.
3. Loosely attach the front mounting bracket to the inner cowl using (2) #14 x 3/4" sheet metal screws (See Figure 12, below).
4. Verify that the evaporator unit is level and square to the dash. Then, tighten all mounting bolts. **NOTE:** Tighten the bolt on the firewall first. Then tighten the front mounting bracket sheet metal screws.

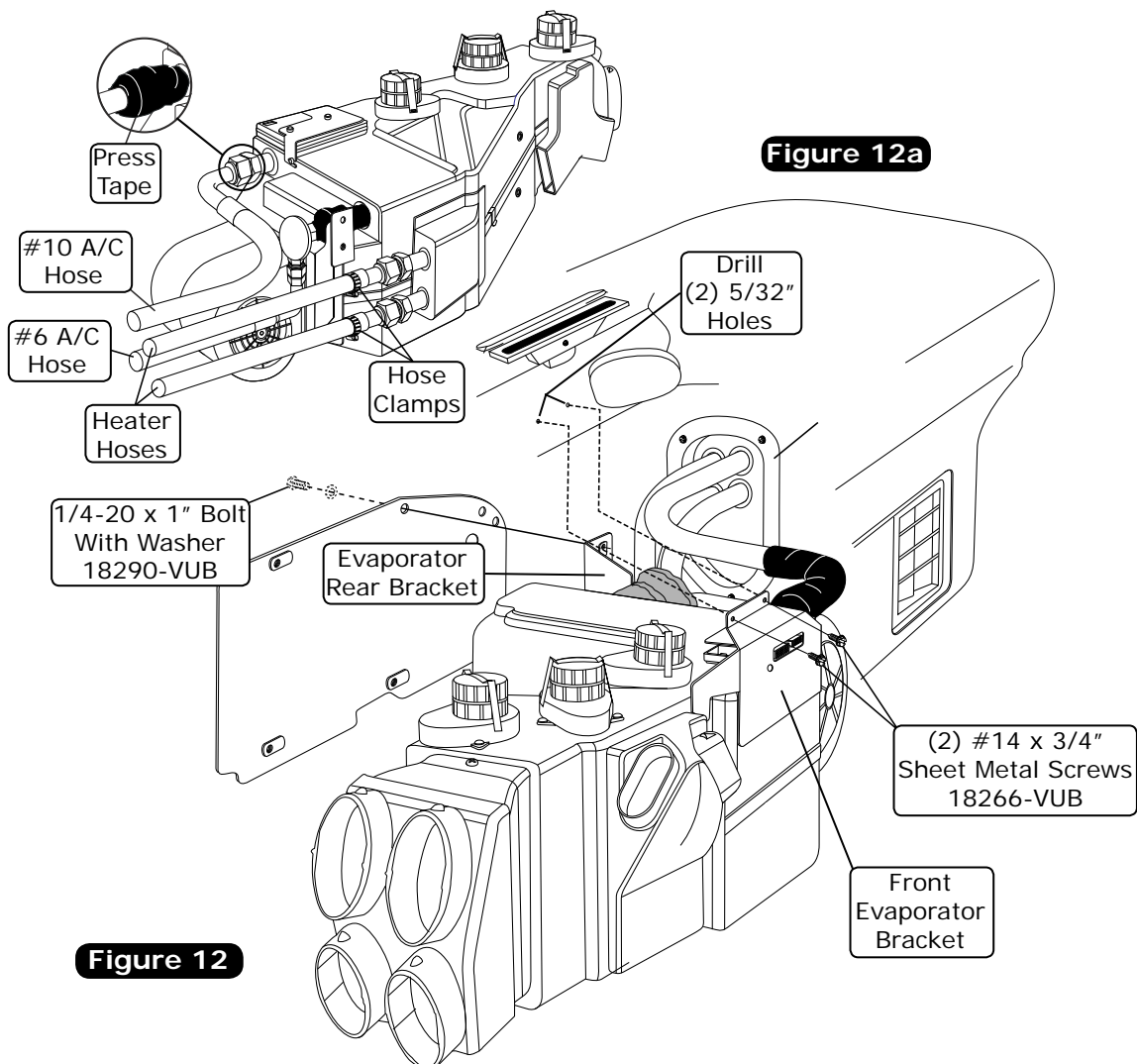



www.vintageair.com

Center Louver Installation

1. Remove the OEM center louver block-off plate.
2. Install (2) OEM center louvers.
3. Install (2) S-clips onto the center louver hose adapter (See Figure 13, below).
4. Install the center louver hose adapter onto the center louvers as shown in Figure 13, below.

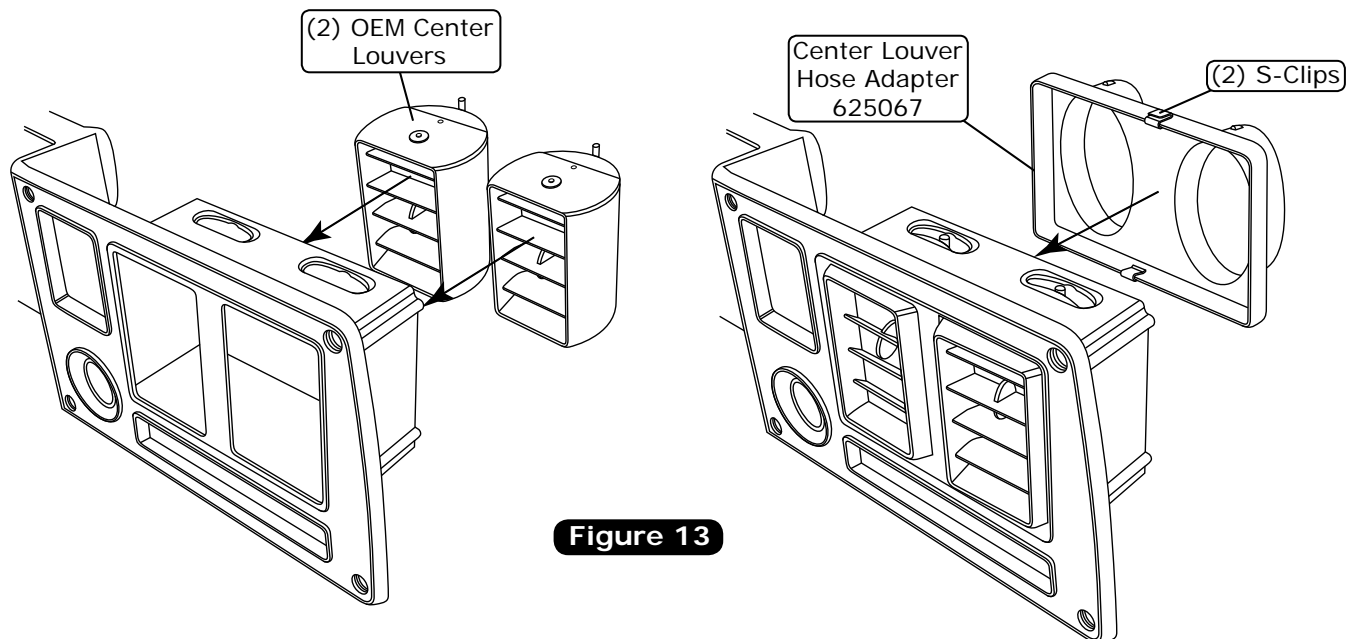

Figure 13

Drain Hose Installation

1. Locate the evaporator drain on the bottom of the evaporator case.
2. In line with the drain, lightly make a mark on the firewall. Measure 1" down and drill a 5/8" hole through the firewall (See Figure 14, below).
3. Install the drain hose onto the bottom of the evaporator unit, and route it through the firewall (See Figure 14, below).

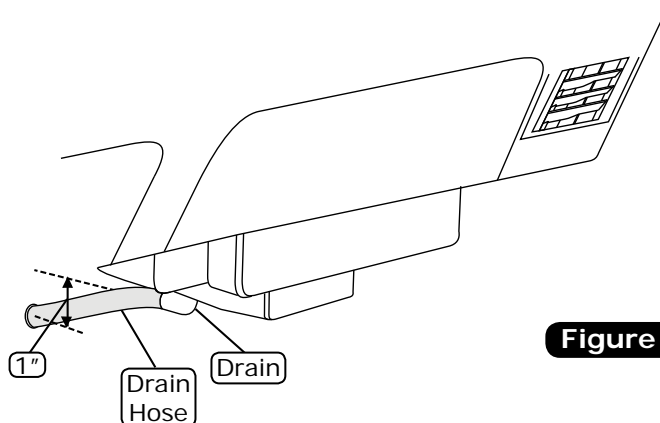
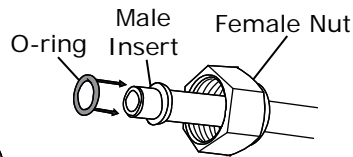
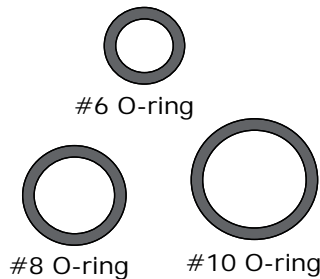

Figure 14



www.vintageair.com

Lubricating O-rings



For a proper seal of fittings: Install supplied O-rings as shown and lubricate with supplied oil.

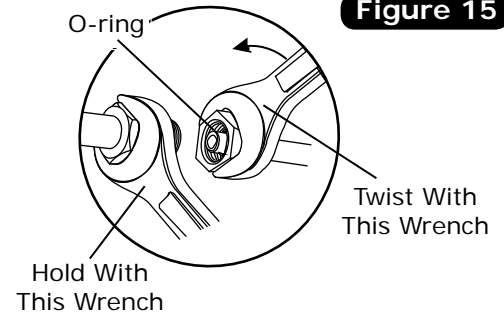
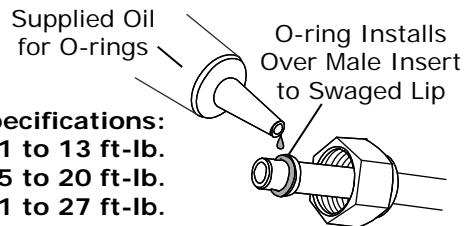

Figure 15

NOTE: Standard torque specifications:

- #6: 11 to 13 ft-lb.
- #8: 15 to 20 ft-lb.
- #10: 21 to 27 ft-lb.

A/C Hose Installation

Standard Hose Kit:

1. Locate the #8 compressor A/C hose. Lubricate (2) #8 O-rings (See Figure 15, above), and connect the 90° female fitting with service port to the #8 discharge port on the compressor. Route the 45° female fitting to the #8 condenser hardline coming through the core support (See Figure 16, Page 16). Tighten each fitting connection as shown in Figure 15, above.
2. Locate the #10 compressor A/C hose. Lubricate (2) #10 O-rings (See Figure 15, above), and connect the 135° female fitting with service port to the #10 suction port on the compressor. Route the 90° female fitting to the #10 fitting on the evaporator (See Figure 12a, Page 13, and Figure 16, Page 16). Tighten each fitting connection as shown in Figure 15, above.
3. Locate the #6 evaporator A/C hose. Lubricate (2) #6 O-rings (See Figure 15, above), and connect the 90° female fitting to the #6 hardline coming through the core support from the drier. Route the other 90° female fitting to the #6 fitting on the evaporator (See Figure 12a, Page 13, and Figure 16, Page 16). Tighten each fitting connection as shown in Figure 15, above.

Modified Hose Kit:

1. Refer to the separate instructions included with the modified hose kit.



www.vintageair.com

Heater Hose & Heater Control Valve Installation

1. Route a piece of heater hose from the water pump to the upper heater core fitting as shown in Figure 12a, Page 13, and Figure 16, below.
2. Route a piece of heater hose from the intake to the heater control valve, and from the heater control valve to the bottom heater core fitting as shown in Figure 12a, Page 13, and Figure 16, below. **NOTE: Install the heater control valve in line with the intake manifold (pressure side) heater hose, and secure it using hose clamps as shown in Figure 16, below. Also note proper flow direction.**

A/C and Heater Hose Routing

NOTE: Vintage Air Systems use 5/8" heater connections. On engines equipped with 3/4" hose nipples, these will need to be removed and replaced with 5/8" nipples (not supplied). For water pumps with a cast-in 3/4" heater outlet, a 3/4" x 5/8" reducer fitting (not supplied) will need to be installed in the heater hose.

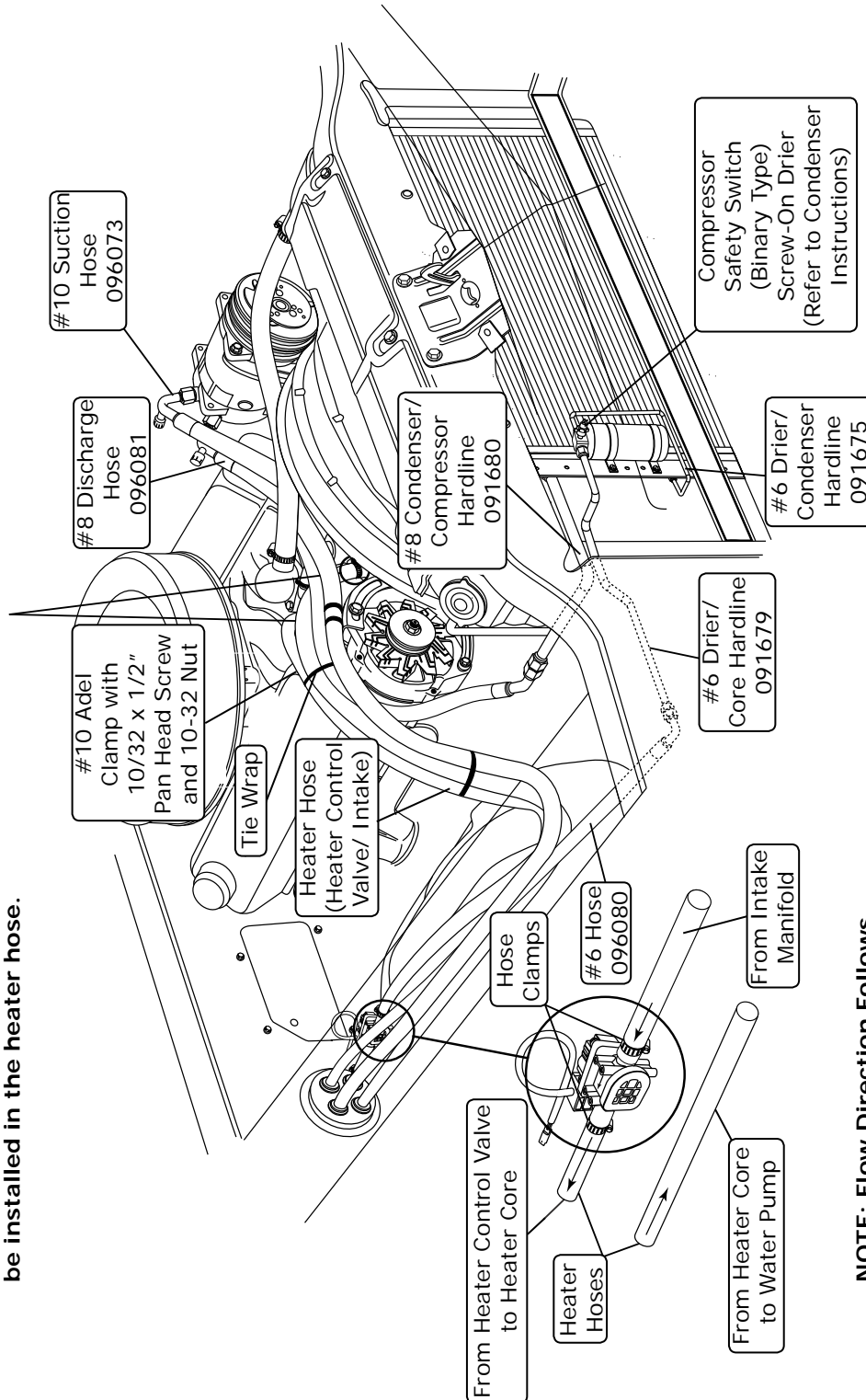

Figure 16

NOTE: Flow Direction Follows Molded Arrow on Valve.



www.vintageair.com

Final Steps

1. Install the duct hoses as shown in Figure 19, Page 18.
2. Install a 3/8" ID grommet into the firewall cover (See Figure 17, below).
3. Route the A/C wires (12 volt/ground/binary switch/heater control valve) through 3/8" grommet as shown in Figure 17, below.
4. Install the control panel assembly. Refer to the control panel instructions.
5. Plug the wiring harnesses into the ECU module on the sub case as shown in Figure 19, Page 18. Wire according to the wiring diagrams on Pages 19 and 20.
6. Install the glove box (See Figure 18, below).
7. Reinstall all previously removed items.
8. Fill radiator with at least a 50/50 mixture of approved antifreeze and distilled water. It is the owner's responsibility to keep the freeze protection at the proper level for the climate in which the vehicle is operated. Failure to follow antifreeze recommendations will cause heater core to corrode prematurely and possibly burst in A/C mode and/or freezing weather, voiding your warranty.
9. Double check all fittings, brackets and belts for tightness.
10. Vintage Air recommends that all A/C systems be serviced by a licensed automotive A/C technician.
11. Evacuate the system for a minimum of 45 minutes prior to charging, and perform a leak check prior to servicing.
12. Charge the system to the capacities stated on Page 4 of this instruction manual.
13. See Operation of Controls procedures on Page 21.

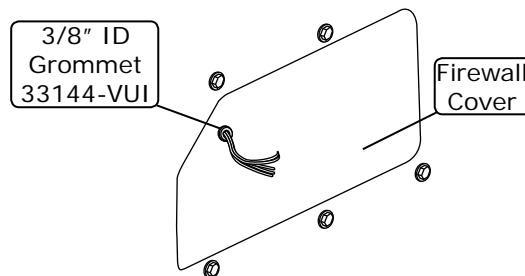

Figure 17

Glove Box Installation

1. Install the supplied glove box, and secure it using OEM screws through the OEM holes (See Figure 18, below).
NOTE: If equipped with the glove box light as shown in Figure 18a, below, modify the plastic glove box using the template provided on Page 25.
2. Reinstall the glove box door.

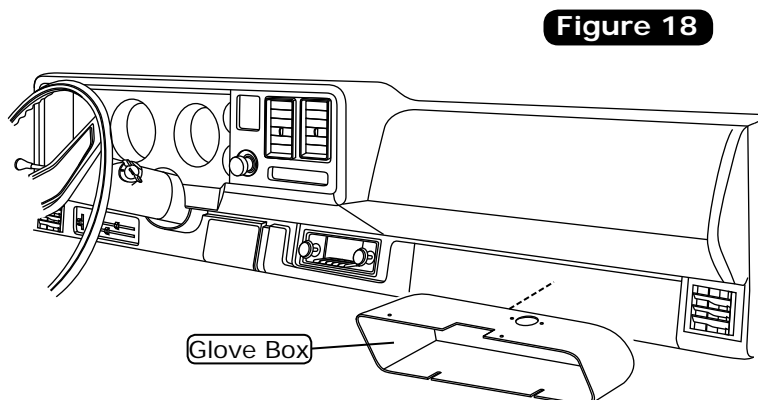

Figure 18

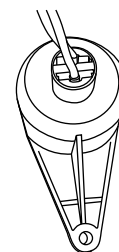
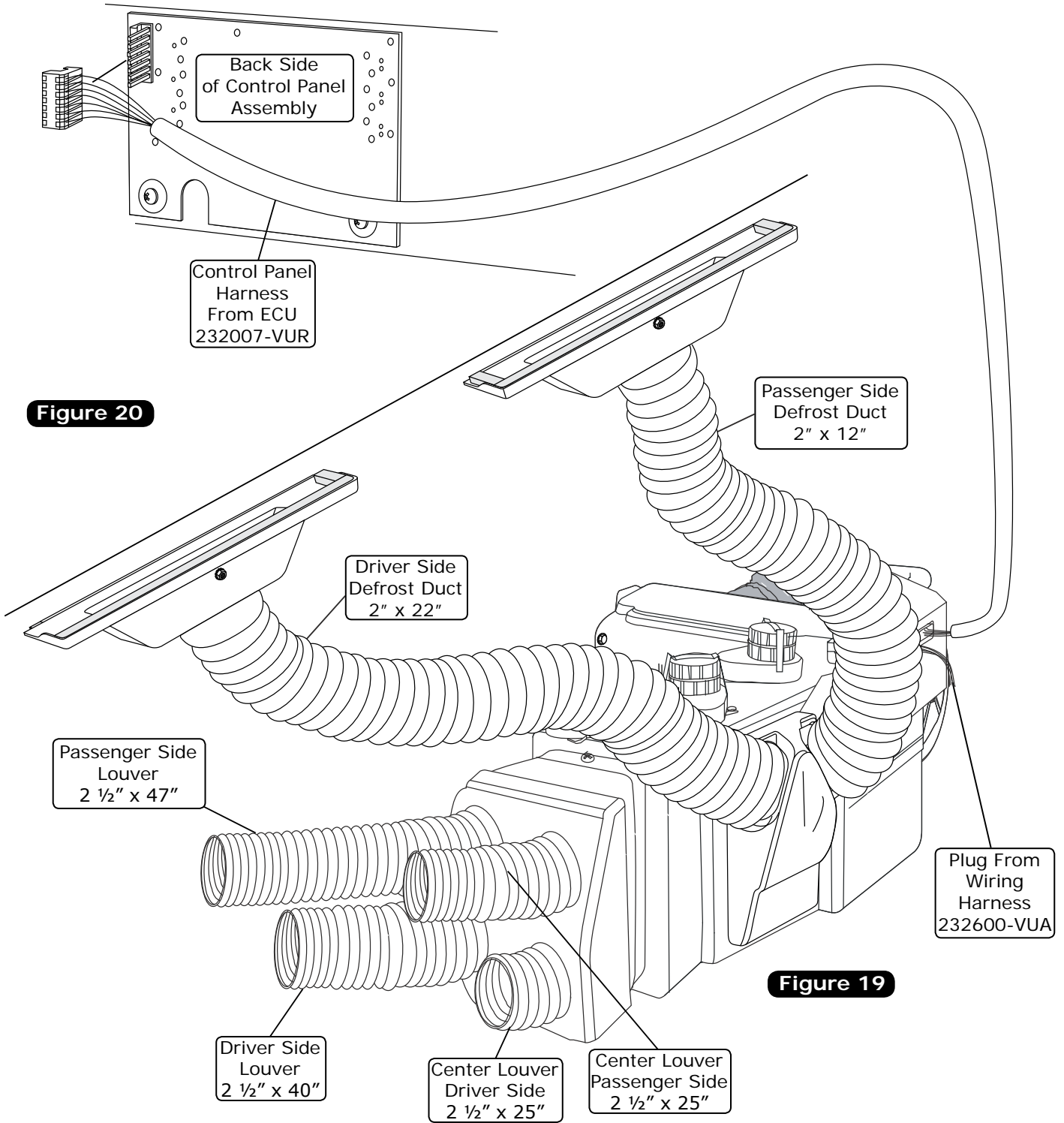

Figure 18a



Control Panel & Duct Hose Routing





www.vintageair.com

Wiring Diagram

232007-VUR

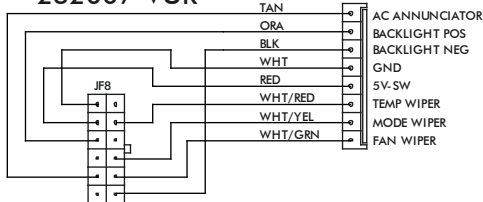

VIEWED FROM WIRE SIDE

232002-VUA

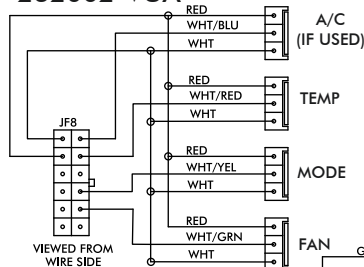

VIEWED FROM WIRE SIDE

PROGRAM

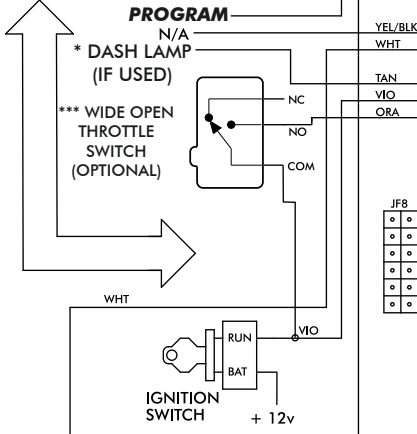

GEN IV ECU

GEN IV WIRING DIAGRAM
REV E, 10/6/2017

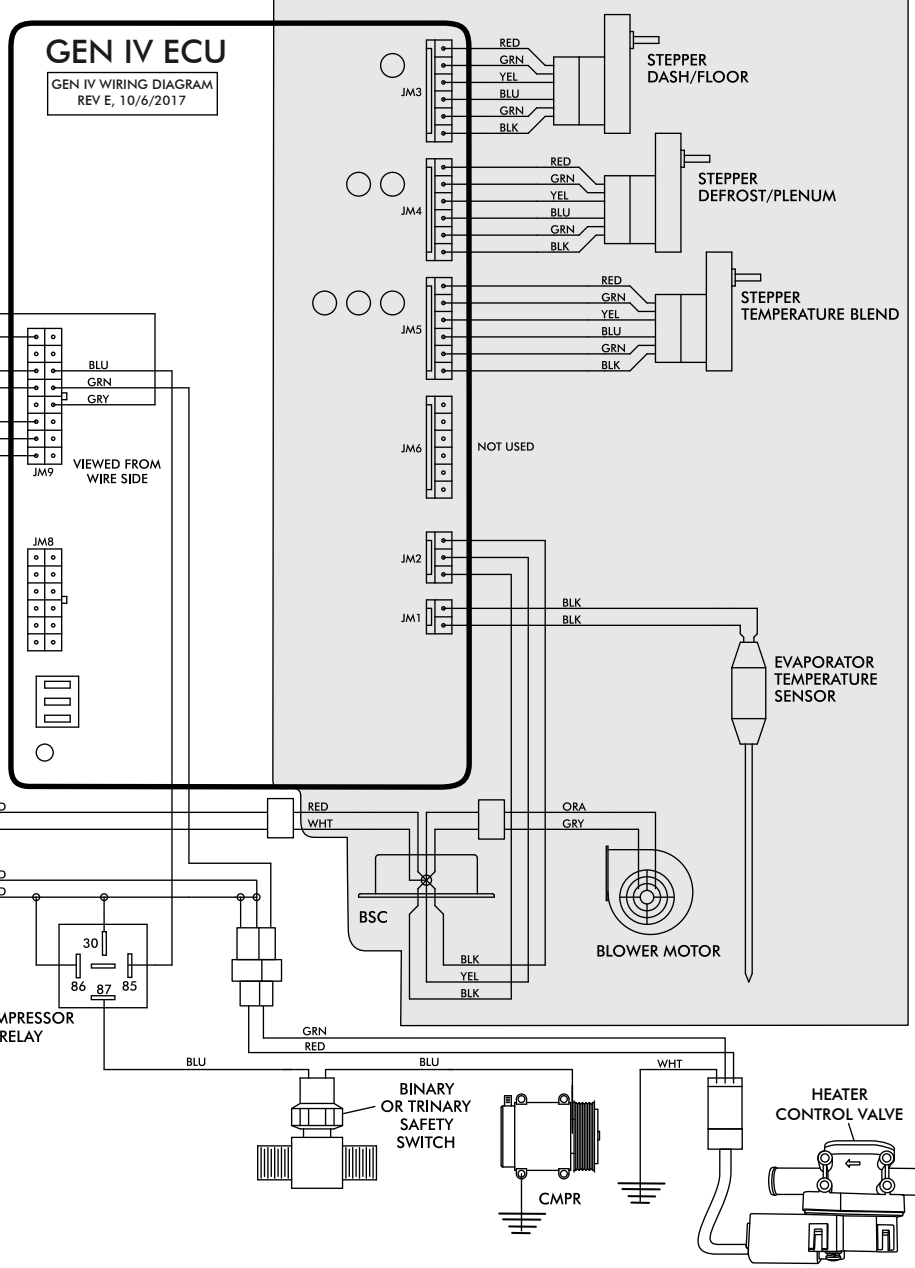

NOTE: = CHASSIS GROUND

* Dash lamp is used only with type 232007-VUR harness.

** Warning: Always mount circuit breaker as close to the battery as possible. (NOTE: Wire between battery and circuit breaker is unprotected and should be carefully routed to avoid a short circuit).

*** Wide open throttle switch contacts close only at full throttle, which disables A/C



www.vintageair.com

Gen IV Wiring Connection Instruction

WIRING HARNESS

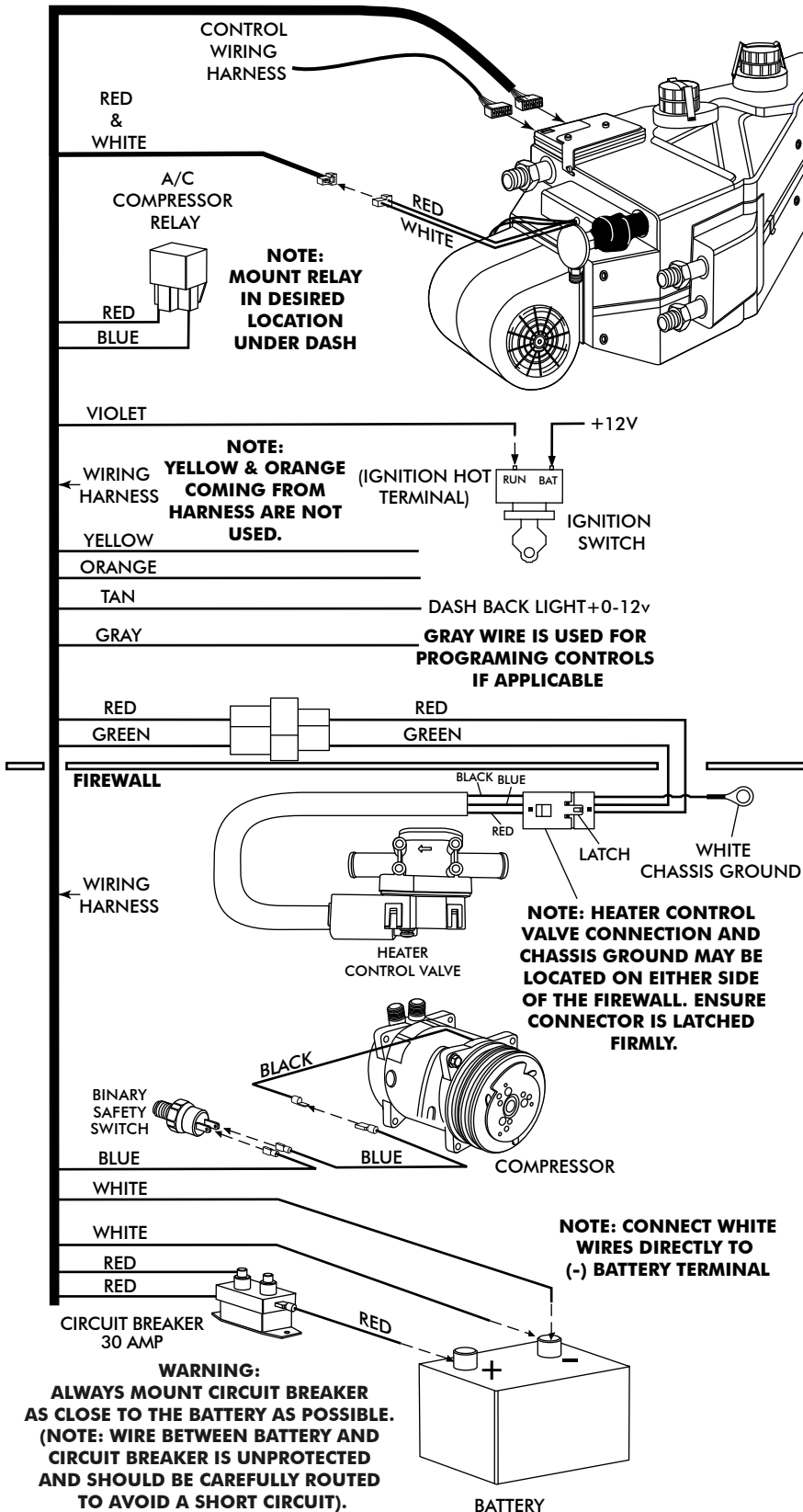

NOTE:
MOUNT RELAY
IN DESIRED
LOCATION
UNDER DASH

NOTE:
YELLOW & ORANGE
COMING FROM
HARNESS ARE NOT
USED.

**GRAY WIRE IS USED FOR
PROGRAMMING CONTROLS
IF APPLICABLE**

**NOTE: HEATER CONTROL
VALVE CONNECTION AND
CHASSIS GROUND MAY BE
LOCATED ON EITHER SIDE
OF THE FIREWALL. ENSURE
CONNECTOR IS LATCHED
FIRMLY.**

**NOTE: CONNECT WHITE
WIRES DIRECTLY TO
(-) BATTERY TERMINAL**

Ignition Switch:
Violet 12V ignition switch source (key on accessory) position must be switched.

Dash Light:
When using a Vintage Air-supplied control panel, connect the tan wire from the Gen IV evaporator wiring harness to the factory dash lights to enable panel backlighting.

Heater Control Valve:
Install with servo motor facing down, as shown. Note flow direction arrow molded into valve body and install accordingly.

Binary/Trinary & Compressor:
Binary: Connect as shown (typical compressor wiring). Be sure compressor body is grounded.
Trinary Switch: Connect according to trinary switch wiring diagram.

Circuit Breaker/Battery:
White **must** run to (-) battery. Red may run to (+) battery or starter. Mount circuit breaker as close to battery as possible.

WARNING:
ALWAYS MOUNT CIRCUIT BREAKER AS CLOSE TO THE BATTERY AS POSSIBLE. (NOTE: WIRE BETWEEN BATTERY AND CIRCUIT BREAKER IS UNPROTECTED AND SHOULD BE CAREFULLY ROUTED TO AVOID A SHORT CIRCUIT).



www.vintageair.com

Operation of Controls

On Gen IV systems with three lever/knob controls, the temperature control toggles between heat and A/C operations. To activate A/C, move the temperature lever/knob all the way to cold and then back it off to the desired vent temperature. For heat operation, move the temperature lever/knob all the way to hot and then adjust to the desired vent temperature. The blower will momentarily change speed, each time you toggle between operations, to indicate the change.

Blower Speed

This lever/knob controls blower speed, from OFF to HI.

Mode Control

This lever/knob controls the mode positions, from DASH to FLOOR to DEFROST, with a blend in between.

Temperature Control

This lever/knob controls the temperature, from HOT to COLD.

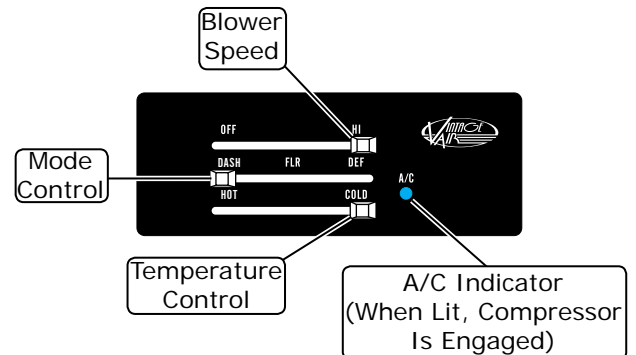

A/C Operation

Blower Speed

Adjust to desired speed.

Mode Control

Adjust to desired mode position (DASH position recommended).

Temperature Control

For A/C operation, adjust to coldest position (Adjust between HOT and COLD to reach desired temperature).



Heat Operation

Blower Speed

Adjust to desired speed.

Mode Control

Adjust to desired mode position (FLOOR position recommended).

Temperature Control

For maximum heating, adjust to hottest position (Adjust between HOT and COLD to reach desired temperature).

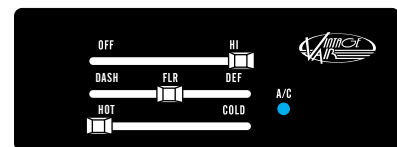

Defrost/De-fog Operation

Blower Speed

Adjust to desired speed.

Mode Control

Adjust to DEFROST position for maximum defrost, or between FLOOR and DEFROST positions for a bi-level blend (Compressor is automatically engaged).

Temperature Control

Adjust to desired temperature.

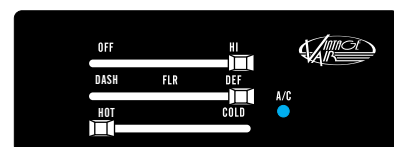



www.vintageair.com

Troubleshooting Guide

Symptom	Condition	Checks	Actions	Notes
1a. Blower stays on high speed when ignition is on.	No other functions work.	Check for damaged pins or wires in control head plug.	Verify that all pins are inserted into plug. Ensure that no pins are bent or damaged in ECU.	Loss of ground on this wire renders control head inoperable.
	All other functions work.	Check for damaged ground wire (white) in control head harness.	Verify continuity to chassis ground with white control head wire at various points.	
		Check for damaged blower switch or potentiometer and associated wiring.	See blower switch check procedure.	
		1b. Blower stays on high speed when ignition is on or off.	Unplug 3-wire BSC control connector from ECU. If blower shuts off, ECU is either improperly wired or damaged.	Be sure the small, 20 GA white ground wire is connected to the battery ground post. If it is, replace the ECU.
Unplug 3-wire BSC control connector from ECU. If blower stays running, BSC is either improperly wired or damaged.	Check to ensure that no BSC wiring is damaged or shorted to vehicle ground. The BSC operates the blower by ground side pulse width modulation switching. The positive wire to the blower will always be hot. If the "ground" side of the blower is shorted to chassis ground, the blower will run on HI.			
2. Compressor will not turn on (All other functions work).	System is not charged.	System must be charged for compressor to engage.	Charge system or bypass pressure switch.	Danger: Never bypass safety switch with engine running. Serious injury can result.
		Check for faulty A/C potentiometer or associated wiring (not applicable to 3-pot controls).	Check continuity to ground on white control head wire. Check for 5V on red control head wire.	
	System is charged.	Check for disconnected or faulty thermistor.	Check 2-pin connector at ECU housing.	Disconnected or faulty thermistor will cause compressor to be disabled.
		Check for faulty A/C potentiometer or associated wiring.	Repair or replace pot/control wiring.	Red wire at A/C pot should have approximately 5V with ignition on. White wire will have continuity to chassis ground. White/Blue wire should vary between 0V and 5V when lever is moved up or down.
	Compressor will not turn off (All other functions work).	Check for faulty A/C relay.	Replace relay.	
				No other part replacements should be necessary.



www.vintageair.com

Troubleshooting Guide (Cont.)

Symptom	Condition	Checks	Actions	Notes
4.	Works when engine is not running; shuts off when engine is started (typically early Gen IV, but possible on all versions).	<p>Noise interference from either ignition or alternator.</p> <p>Verify connections on power lead, ignition lead, and both white ground wires.</p> <p>Verify battery voltage is greater than 10 volts and less than 16.</p>	<p>Install capacitors on ignition coil and alternator. Ensure good ground at all points. Relocate coil and associated wiring away from ECU and ECU wiring. Check for burned or loose plug wires.</p> <p>Check for positive power at heater valve green wire and blower red wire. Check for ground on control head white wire.</p> <p>Verify proper meter function by checking the condition of a known good battery.</p>	<p>Ignition noise (radiated or conducted) will cause the system to shut down due to high voltage spikes. If this is suspected, check with a quality oscilloscope. Spikes greater than 16V will shut down the ECU. Install a radio capacitor at the positive post of the ignition coil (see radio capacitor installation bulletin). A faulty alternator or worn out battery can also result in this condition.</p>
5.	System will not turn on, or runs intermittently.	<p>Will not turn on under any conditions.</p> <p>No mode change at all.</p> <p>Partial function of mode doors.</p>	<p>Check for damaged mode switch or potentiometer and associated wiring.</p> <p>Check for obstructed or binding mode doors.</p> <p>Check for damaged stepper motor or wiring.</p>	<p>Typically caused by evaporator housing installed in a bind in the vehicle. Be sure all mounting locations line up and don't have to be forced into position.</p>
6.	Blower turns on and off rapidly.	<p>Battery voltage is at least 12V.</p> <p>Battery voltage is less than 12V.</p>	<p>Ensure all system grounds and power connections are clean and tight.</p> <p>Charge battery.</p>	<p>System shuts off blower at 10V. Poor connections or weak battery can cause shutdown at up to 11V.</p>
7.	Erratic functions of blower, mode, temp, etc.	<p>Check for damaged switch or pot and associated wiring.</p>	<p>Repair or replace.</p>	
8.	When ignition is turned on, blower momentarily comes on, then shuts off. This occurs with the blower switch in the OFF position.	<p>This is an indicator that the system has been reset. Be sure the red power wire is on the battery post, and not on a switched source. Also, if the system is pulled below 7V for even a split second, the system will reset.</p>	<p>Run red power wire directly to battery.</p>	



www.vintageair.com

Kick Panel Modification Template

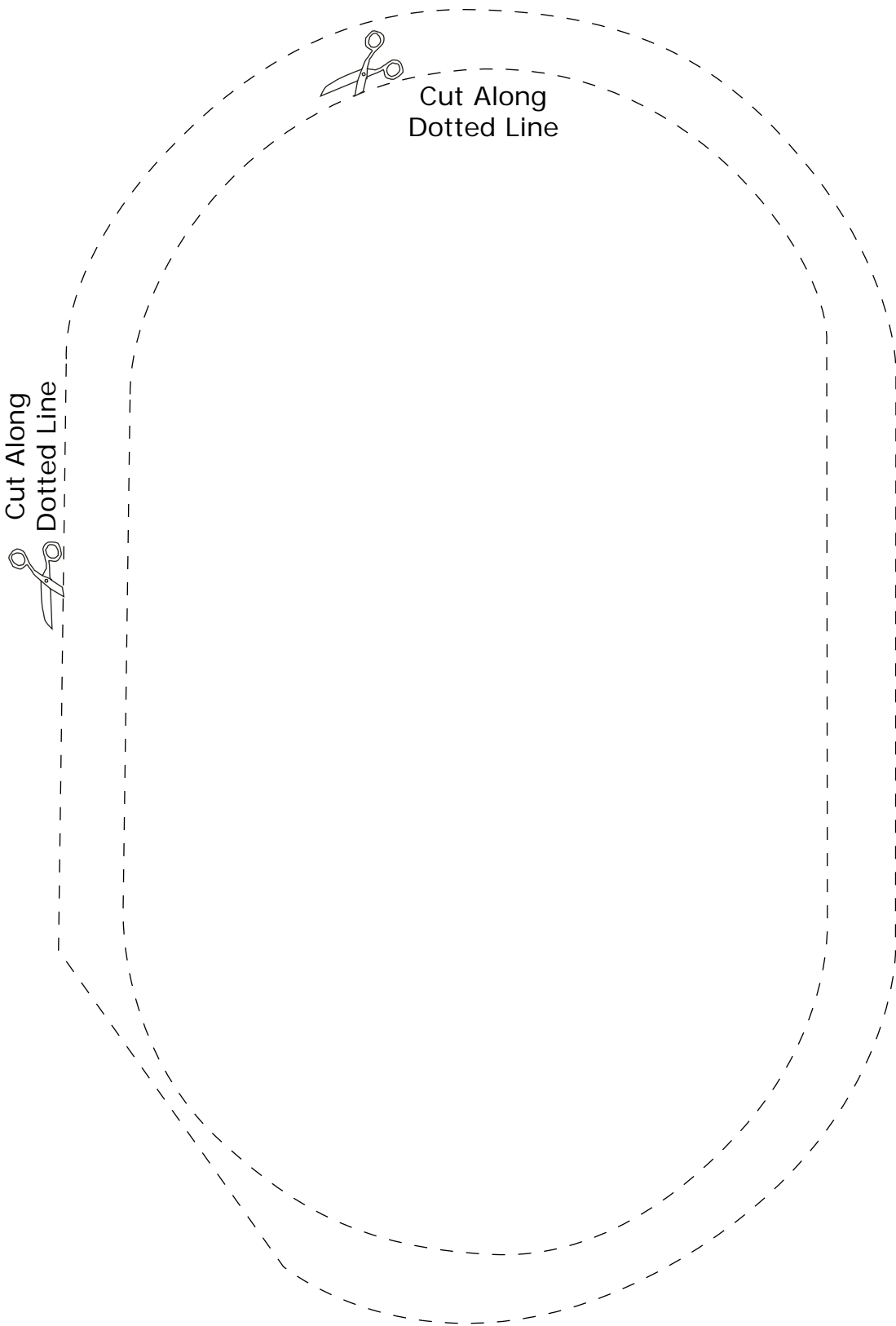

NOTE: Due to printing variances, measure the line below before using this template. If template is scaled properly, the line should measure 6 inches.





www.vintageair.com

Glove Box Light Template

NOTE: Due to printing variances, measure the line below before using this template. If template is scaled properly, the line should measure 6 inches.

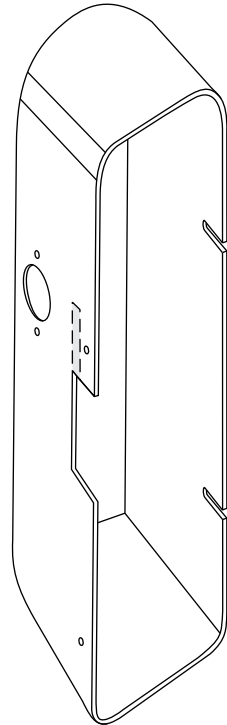
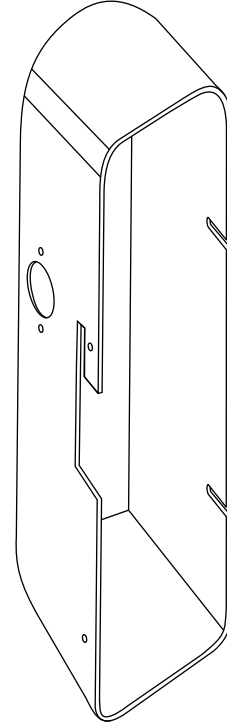
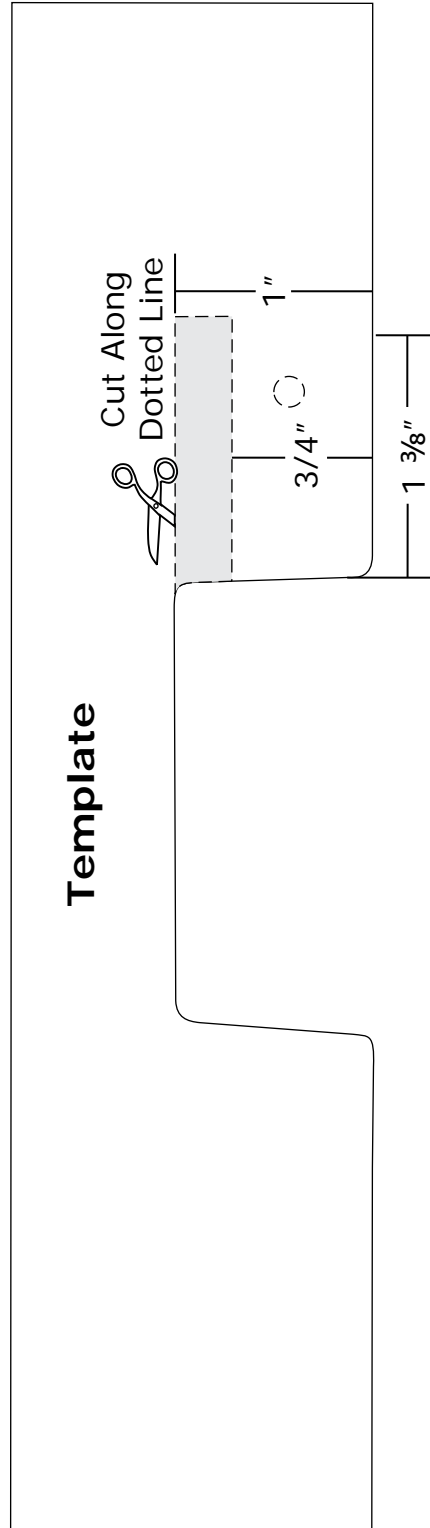
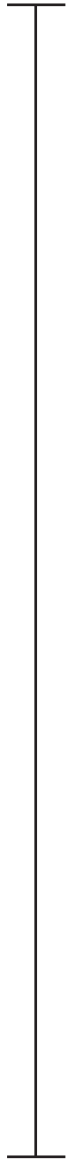



www.vintageair.com

Packing List: Evaporator Kit (561180)

No.	Qty.	Part No.	Description
1.	1	744004-VUE	Gen IV Evaporator Sub Case
2.	1	781173	Accessory Kit

Checked By: _____
 Packed By: _____
 Date: _____

1

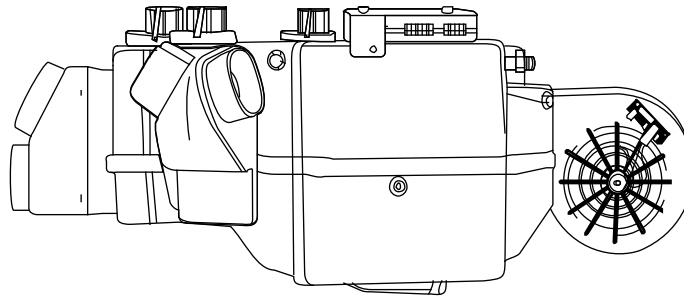

Gen IV Evaporator
Sub Case
744004-VUE

2

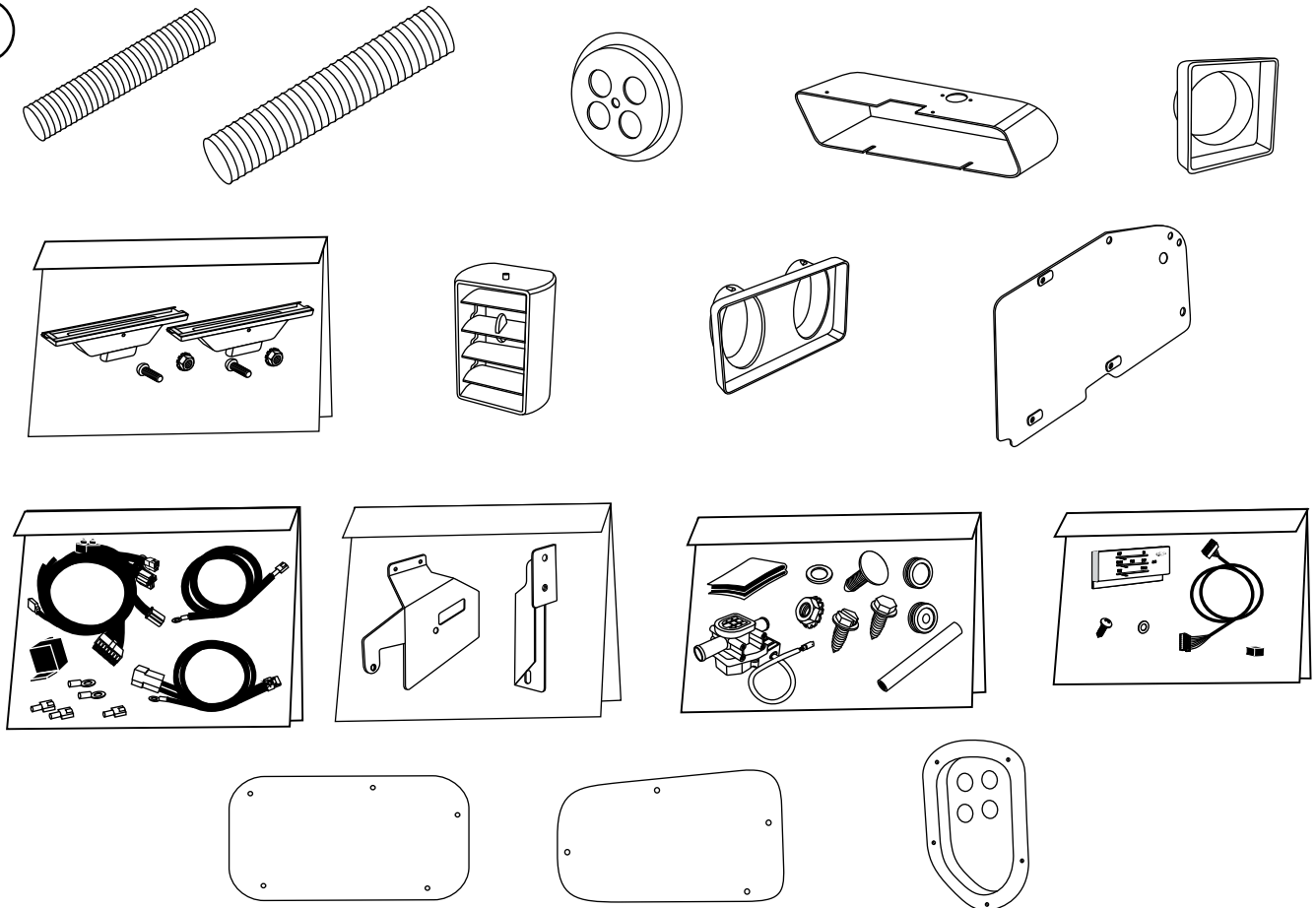

Accessory Kit
781173

**NOTE: Images may not depict actual parts and quantities.
Refer to packing list for actual parts and quantities.**