

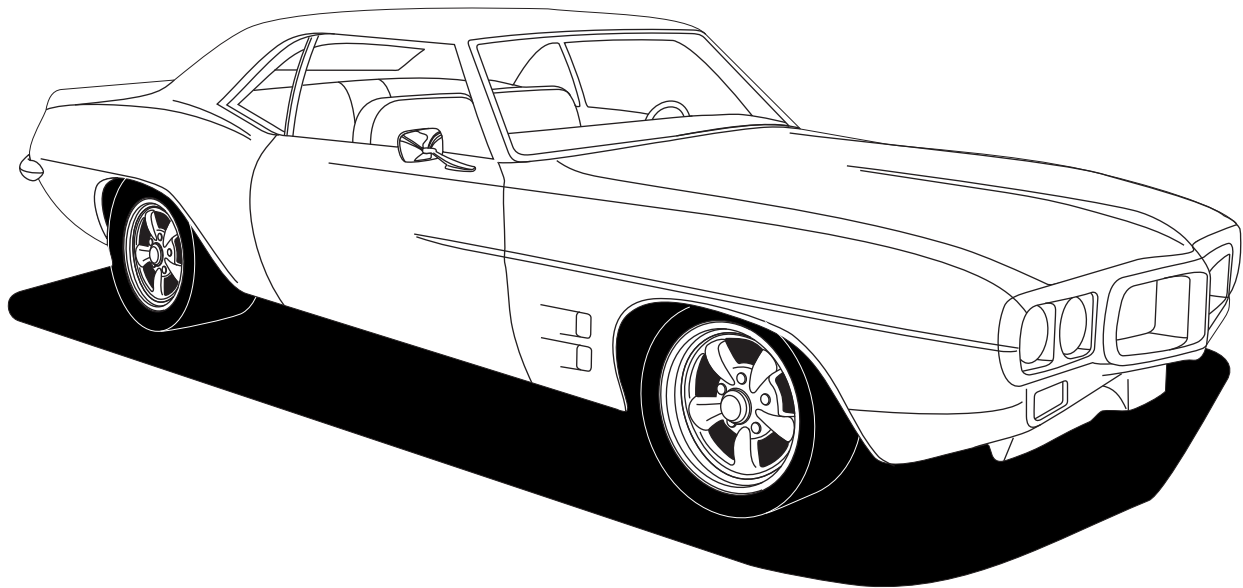

an ISO 9001:2015 Registered Company

1969 Pontiac Firebird

without Factory Air
Evaporator Kit
561168



18865 Goll St. San Antonio, TX 78266
Phone: 800-862-6658
Sales: sales@vintageair.com
Tech Support: tech@vintageair.com
www.vintageair.com



Table of Contents

3. Packing List/Parts Disclaimer
4. Information Page
5. Wiring Notice
6. Engine Compartment, Condenser Assembly & Installation, Compressor & Brackets, Pulleys
Figure 1
7. Passenger Compartment
Figures 2 & 3
8. Defrost Duct & Fresh Air Cap Installation, Driver and Passenger Side Hose Adapter Installation
Figures 4 & 5
9. Instrument Panel Modification, Center Louver Installation
Figures 6 & 7
10. Fresh Air Cover Installation, Kick Panel Fresh Air Cap Installation
Figures 8 & 9
11. Firewall Cover, Evaporator Bracket and Heater Hose Fitting Installation
Figures 10 & 11
12. Evaporator Bracket and Heater Hose Fitting Installation (Cont.)
Figure 12
13. Kick Panel Modification
Figures 13 & 13a
14. Evaporator Installation
Figures 14 & 14a
15. Drain Hose Installation, Lubricating O-rings, A/C Hose Installation
Figures 15 & 16
16. Heater Hose & Heater Control Valve Installation
Figure 17
17. Final Steps, Glove Box Installation
Figures 18, 19, 20
18. Control Panel & Duct Hose Routing
Figure 21
19. Wiring Diagram
20. Gen IV Wiring Connection Instruction
21. Operation of Controls
22. Troubleshooting Information
23. Troubleshooting Information (Cont.)
24. Evaporator Kit Packing List



Packing List Evaporator Kit (561168)

No.	Qty.	Part No.	Description
1.	1	744013	Gen IV Evap Sub Case w/90 Defrost w/204 ECU
2.	1	781179	Accessory Kit 1969 Firebird wo A/C

**** Before beginning installation, open all packages and check contents of shipment. Please report any shortages directly to Vintage Air within 15 days. After 15 days, Vintage Air will not be responsible for missing or damaged items.**

①

**Gen IV Evaporator Sub Case
w/ 90 Defrost w/ 204 ECU
744013**

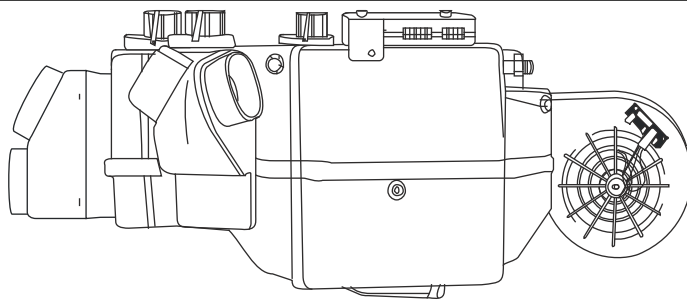

②

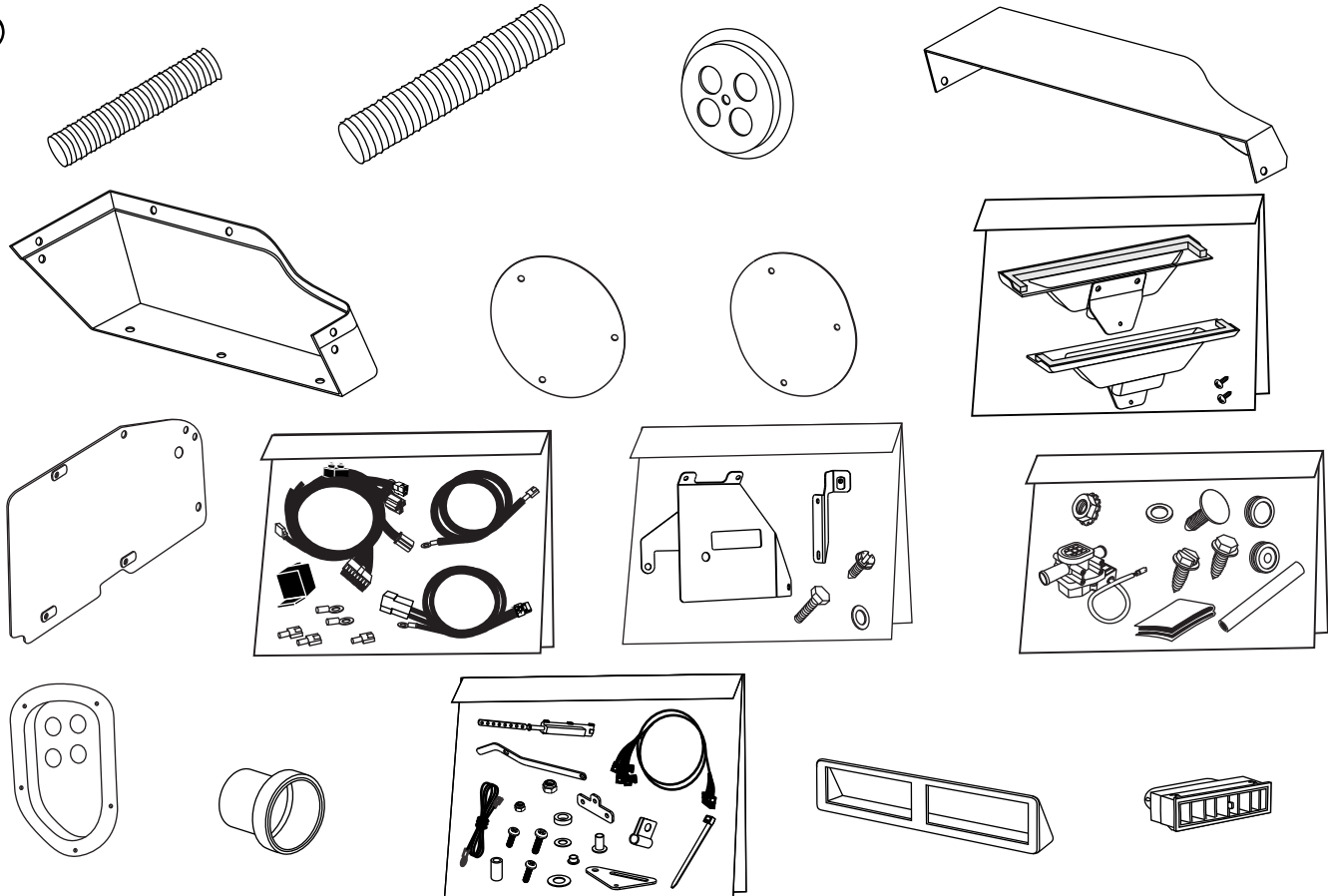

**Accessory Kit
781179**

**NOTE: Images may not depict actual parts and quantities.
Refer to packing list for actual parts and quantities.**



Important Notice—Please Read

For Maximum System Performance, Vintage Air Recommends the Following:

NOTE: Vintage Air systems are designed to operate with R134a refrigerant only. Use of any other refrigerant could damage your A/C system and/or vehicle, and possibly cause a fire, in addition to potentially voiding the warranties of the A/C system and its components.

Refrigerant Capacities:

Vintage Air System: 1.8 lbs. (28.8 oz.) or 816 grams of **R134a**, charged by weight with a quality charging station or scale. **NOTE: Use of the proper type and amount of refrigerant is critical to system operation and performance.**

Other Systems: Consult manufacturer's guidelines.

Lubricant Capacities:

New Vintage Air-Supplied Sanden Compressor: No additional oil needed (Compressor is shipped with proper oil charge).

All Other Compressors: Consult manufacturer (Some compressors are shipped dry and will need oil added).

Safety Switches

Your Vintage Air system is equipped with a binary pressure safety switch. A binary switch disengages the compressor clutch in cases of extreme low pressure conditions (refrigerant loss) or excessively high head pressure (406 PSI) to prevent compressor damage or hose rupture. A trinary switch combines Hi/Lo pressure protection with an electric fan operation signal at 254 PSI, and should be substituted for use with electric fans. Compressor safety switches are extremely important since an A/C system relies on refrigerant to circulate lubricant.

Service Info:

Protect Your Investment: Prior to assembly, it is critical that the compressor, evaporator, A/C hoses and fittings, hardlines, condenser and receiver/drier remain capped. Removing caps prior to assembly will allow moisture, insects and debris into the components, possibly leading to reduced performance and/or premature failure of your A/C system. This is especially important with the receiver/drier.

Additionally, when caps are removed for assembly, **BE CAREFUL!** Some components are shipped under pressure with dry nitrogen.

Evacuate the System for 35-45 Minutes: Ensure that system components (Drier, compressor, evaporator and condenser) are at a temperature of at least 85°F. On a cool day, the components can be heated with a heat gun **or** by running the engine with the heater on before evacuating. Leak check and charge to specifications.

Bolts Passing Through Cowl and/or Firewall:

To ensure a watertight seal between the passenger compartment and the vehicle exterior, for all bolts passing through the cowl and/or firewall, Vintage Air recommends coating the threads with silicone prior to installation.

Heater Hose (not included with this kit):

Heater hose may be purchased from Vintage Air (Part#31800-VUD) or your local parts retailer. Routing and required length will vary based on installer preference.



Important Wiring Notice—Please Read

Some vehicles may have had some or all of their radio interference capacitors removed. There should be a capacitor found at each of the following locations:

- 1. On the positive terminal of the ignition coil.**
- 2. If there is a generator, on the armature terminal of the generator.**
- 3. If there is a generator, on the battery terminal of the voltage regulator.**

Most alternators have a capacitor installed internally to eliminate what is called “whining” as the engine is revved. If whining is heard in the radio, or just to be extra cautious, a radio interference capacitor can be added to the battery terminal of the alternator.

It is also important that the battery lead is in good shape and that the ground leads are not compromised. There should be a heavy ground from the battery to the engine block, and additional grounds to the body and chassis.

If these precautions are not observed, it is possible for voltage spikes to be present on the battery leads. These spikes come from ignition systems and charging systems, and from switching some of the vehicle’s other systems on and off. Modern computer-operated equipment can be sensitive to voltage spikes on the power leads, which can cause unexpected resets, strange behavior and/or permanent damage.

Vintage Air strives to harden our products against these types of electrical noise, but there is a point where a vehicle’s electrical system can be degraded so much that nothing can help.

Radio interference capacitors should be available at most auto and truck parts suppliers. They typically are cylindrical in shape, a little over an inch long and a little over a half-inch in diameter, and they have a single lead coming from one end of the cylinder with a terminal on the end of the wire, as well as a mounting clip which is screwed into a good ground on the vehicle. The specific value of the capacitance is not too significant in comparison to ignition capacitors that are matched with the coil to reduce pitting of the points.

- Care must be taken, when installing the compressor lead, not to short it to ground. The compressor lead must not be connected to a condenser fan or to any other auxiliary device. Shorting to ground or connecting to a condenser fan or any other auxiliary device may damage wiring or the compressor relay, and/or cause a malfunction.
- When installing ground leads on Gen IV systems, the blower control ground and ECU ground must be connected directly to the negative battery post.
- For proper system operation, the heater control valve must be connected to the ECU.



Engine Compartment

Before starting the installation, check the function of the vehicle (horn, lights, etc.) for proper operation. Study the instructions, illustrations & diagrams.

Perform the Following:

1. Remove battery and battery tray (retain) (See Figure 1, below).
2. Drain radiator.
3. Remove hood latch assembly (retain) including hood latch support.
4. Remove heater blower motor assembly (discard). **NOTE: To remove the heater blower motor assembly (under hood) and the air distribution system (under dash), the factory manual indicates doing the following: Remove right lower rocker molding. Remove fender attaching bolts. Remove skirt to fender and skirt to reinforcement screws. Pull out on lower portion of fender, moving the skirt away from the fender flange and firewall. Block the skirt with a 2 x 4 block of wood. To avoid damage to paint and sheet metal, and for ease of removal and replacement of components, Vintage Air suggests that the right fender be removed and the inner panel be lowered (See Figure 1, below).**
5. Remove OEM heater hoses (discard) (See Figure 1, below).
6. Remove OEM heater wiring/vacuum harness molded grommet (See Figure 1, below).

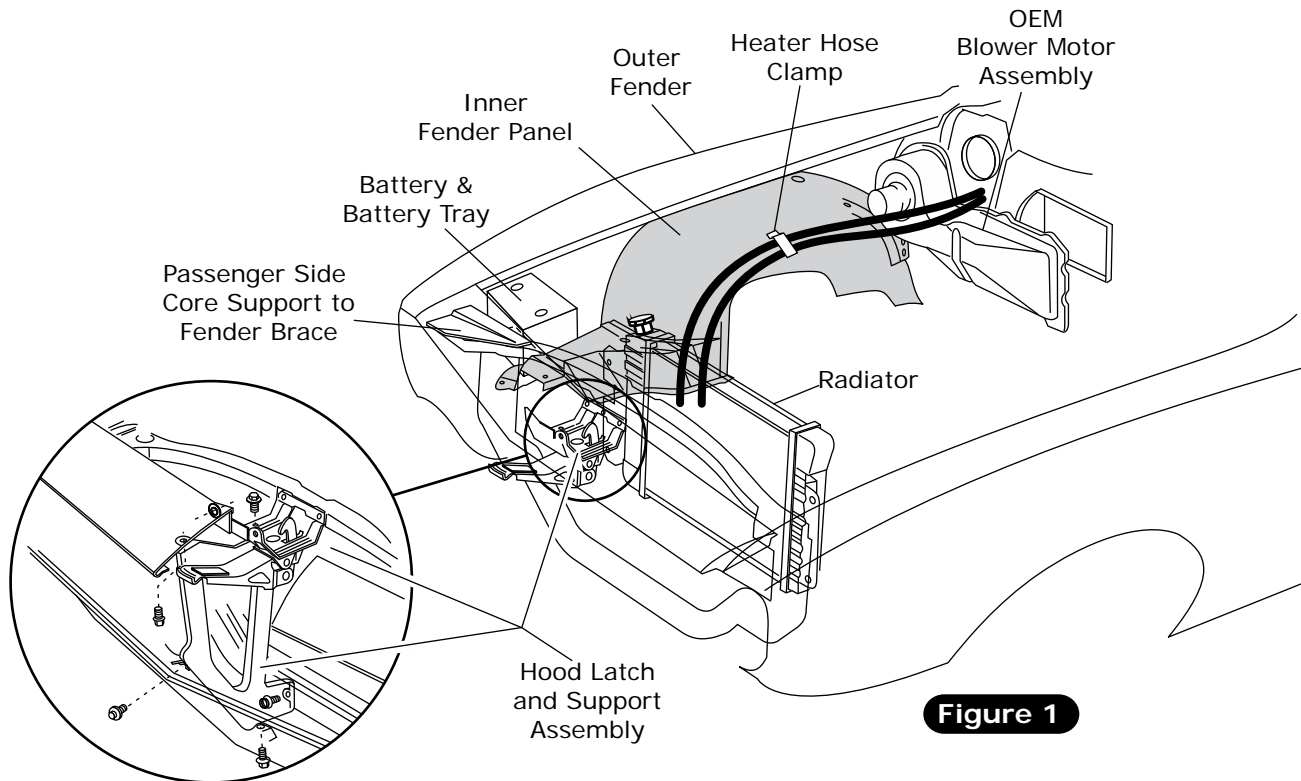

Figure 1

Condenser Assembly & Installation

1. Refer to separate instructions included with the condenser kit to install the condenser.
2. Binary switch installation (Refer to condenser instructions).

Compressor & Brackets

1. Refer to separate instructions included with the bracket kit to install the compressor bracket.

Pulleys

1. In most instances, the belt lengths will remain the same.



Passenger Compartment

Perform the Following:

1. Remove the ashtray (retain) (See Figure 2, below).
2. Remove ashtray slider assembly (retain) (See Figure 2, below).
3. Remove glove box door (retain) (See Figure 2, below).
4. Remove and discard OEM glove box.
5. Remove astro ventilation ducts (See Figure 2, below).
6. Remove the radio (retain) (See Figure 2, below).
7. Remove OEM control panel (See Figure 2, below).
8. Loosen and lower steering column (See Figure 2, below).
9. Remove the instrument panel assembly (retain) (See Figure 2, below).
10. Remove the OEM defrost duct (discard) (See Figure 3, below).
11. Remove the OEM heater assembly (discard) (See Figure 3, below).
12. Remove passenger side kick panel.

NOTE: Remove the front seats (Optional, for ease of A/C installation only).

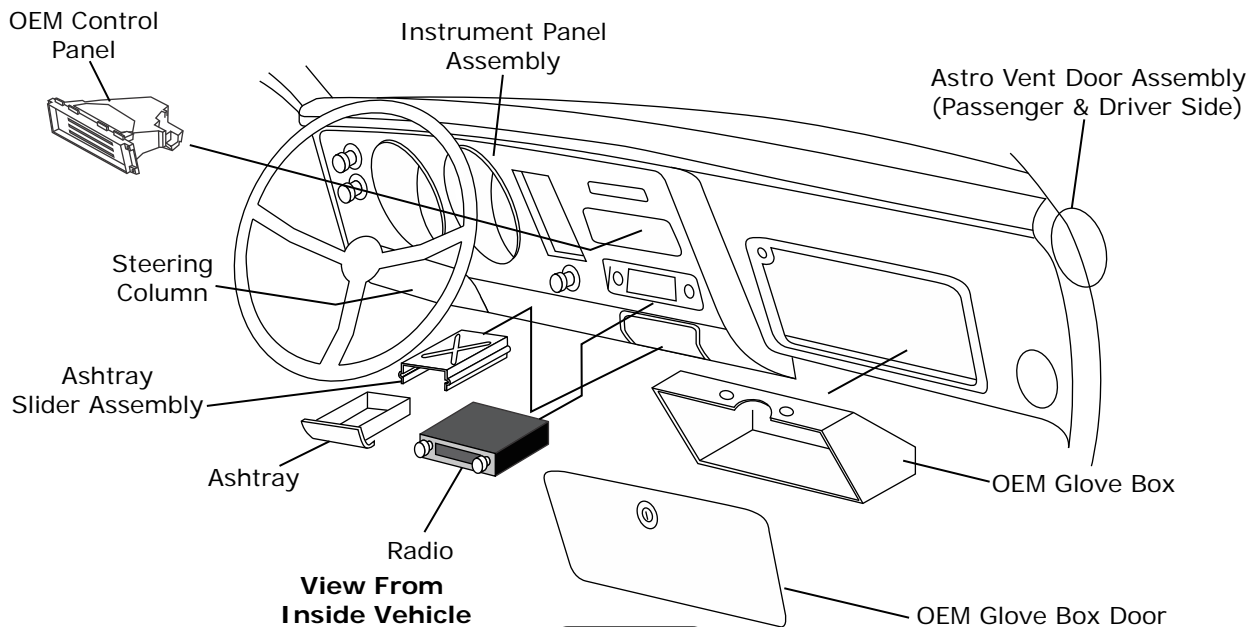

Figure 2

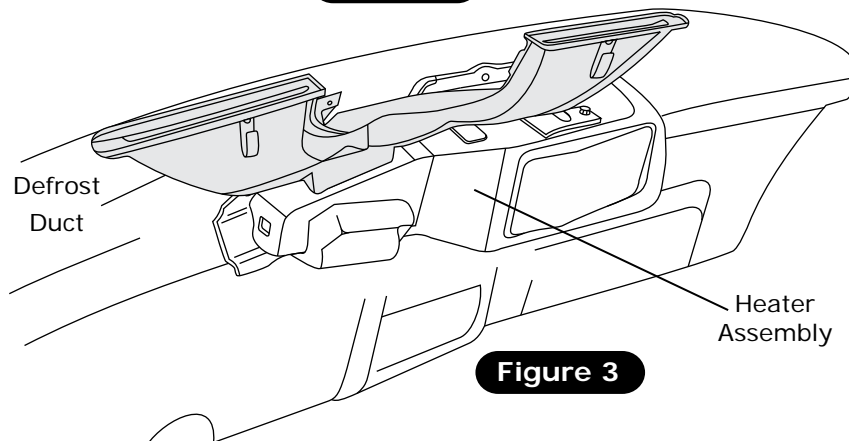

Figure 3



Defrost Duct & Fresh Air Cap Installation

1. Install defrost ducts under dash as shown in Figure 4, below. Align defrost duct with defrost opening in dash, and hold in place. Use bracket as template and drill 7/64" hole. Secure using a #10 X 1/2" hex sheet metal screw.
2. If vehicle is equipped with astro ventilation, you must install driver and passenger side fresh air covers, and secure using OEM hardware (See Figure 4, below).

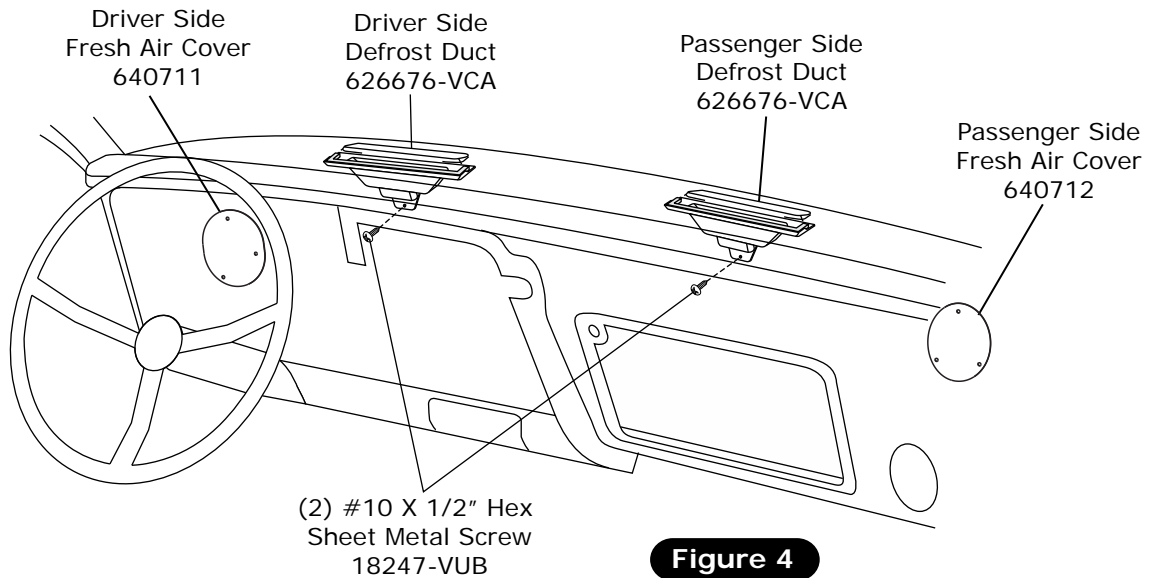

Figure 4

Driver and Passenger Side Hose Adapter Installation

1. Install driver and passenger side hose adapters on OEM louvers and secure using (3) #6 x 3/8" PH pan head screws (See Figure 5, below).

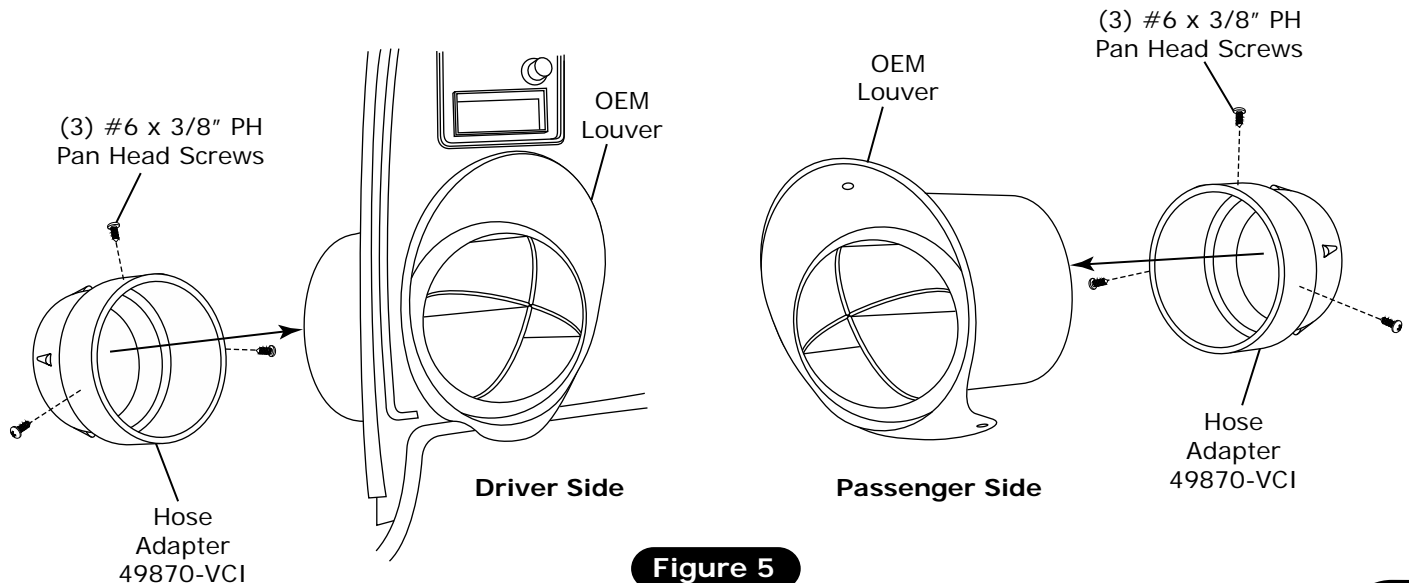

Figure 5



Instrument Dash Panel Modification

1. Mark and cut instrument dash panel as shown in Figure 6, below.

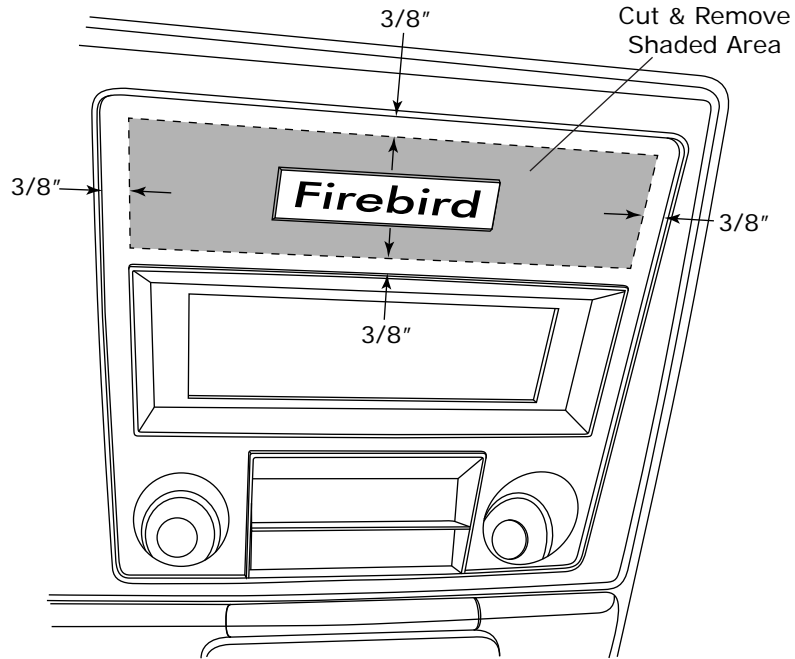

Figure 6

Center Louver Installation

1. Install center louver assembly in instrument dash panel as shown in Figure 7, below.

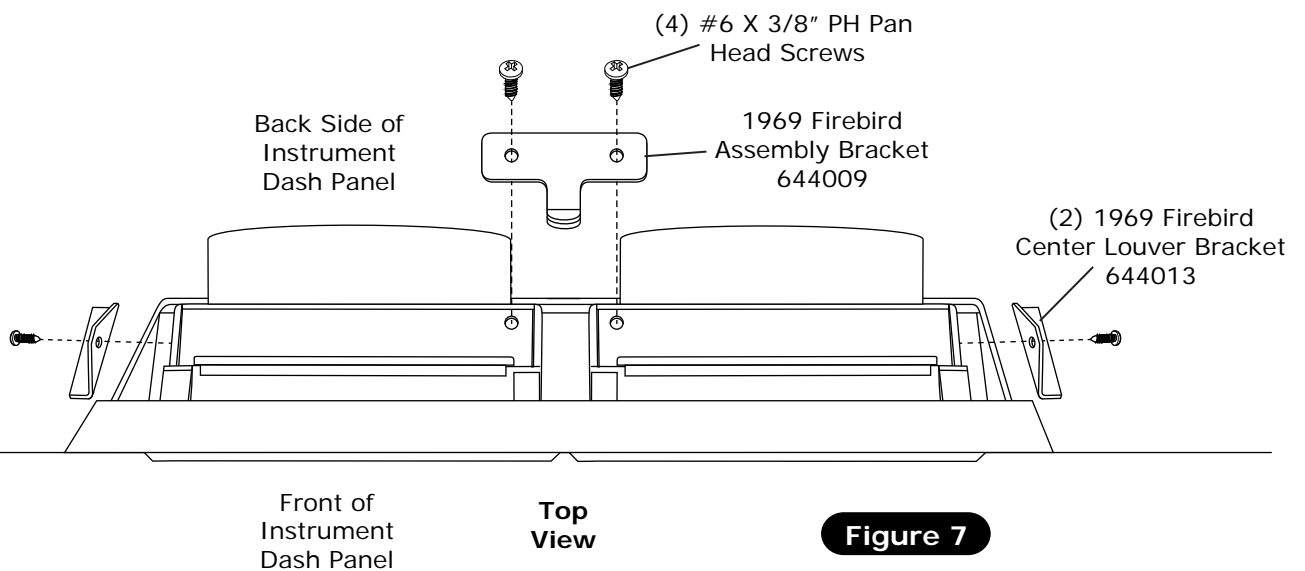

Figure 7



Fresh Air Cover Installation

1. Install (4) grommets in fresh air cap (See Figure 8, below).
2. Apply a 1/4" bead of silicone around the back side of the fresh air cap as shown in Figure 8, below.
3. Attach fresh air cap to firewall using a 1/4-20 X 1 1/2" bolt and washer (See Figure 8, below). **NOTE: Fresh air cap installs on engine side of firewall.**
4. Install 1 1/4" plug in firewall (See Figure 8, below).

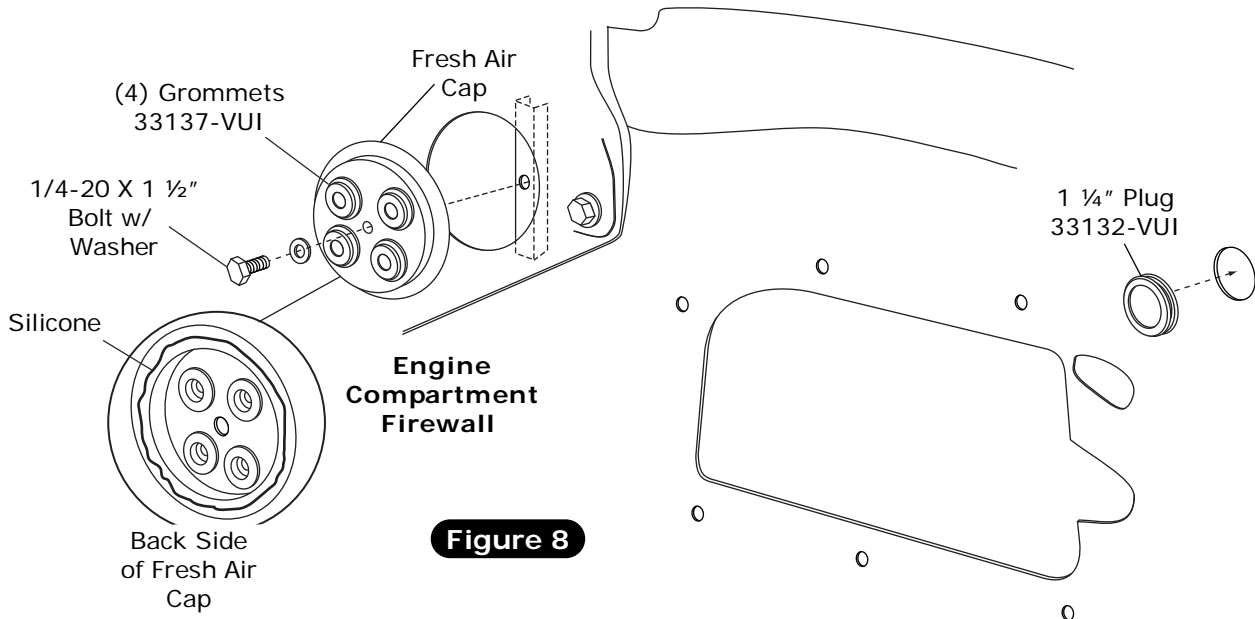

Figure 8

Kick Panel Fresh Air Cap Installation

1. Install (4) grommets in kick panel fresh air cap (See Figure 9a, below).
2. Route A/C and heater hose through fresh air cap and kick panel fresh air cap as shown in Figures 9 and 9b, below.
3. Apply a 1/4" bead of silicone around the back side of kick panel fresh air cap as shown in Figure 9, below.
4. Secure kick panel fresh air cap using (5) OEM screws as shown in Figure 9b, below.

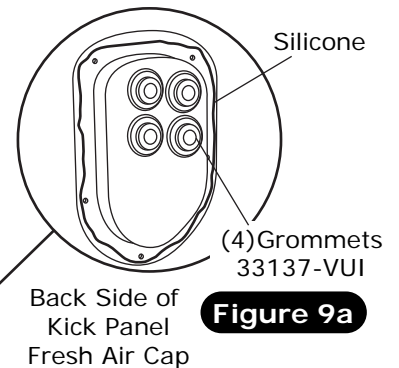

Figure 9a

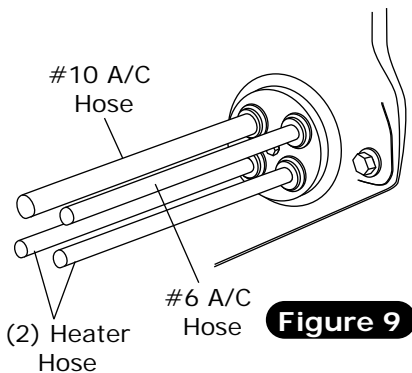

Figure 9

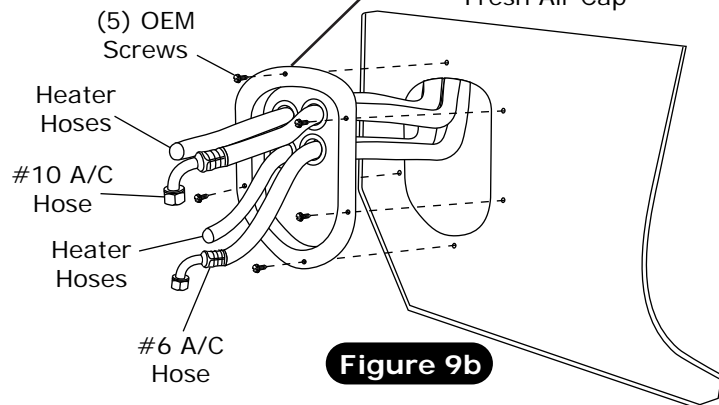
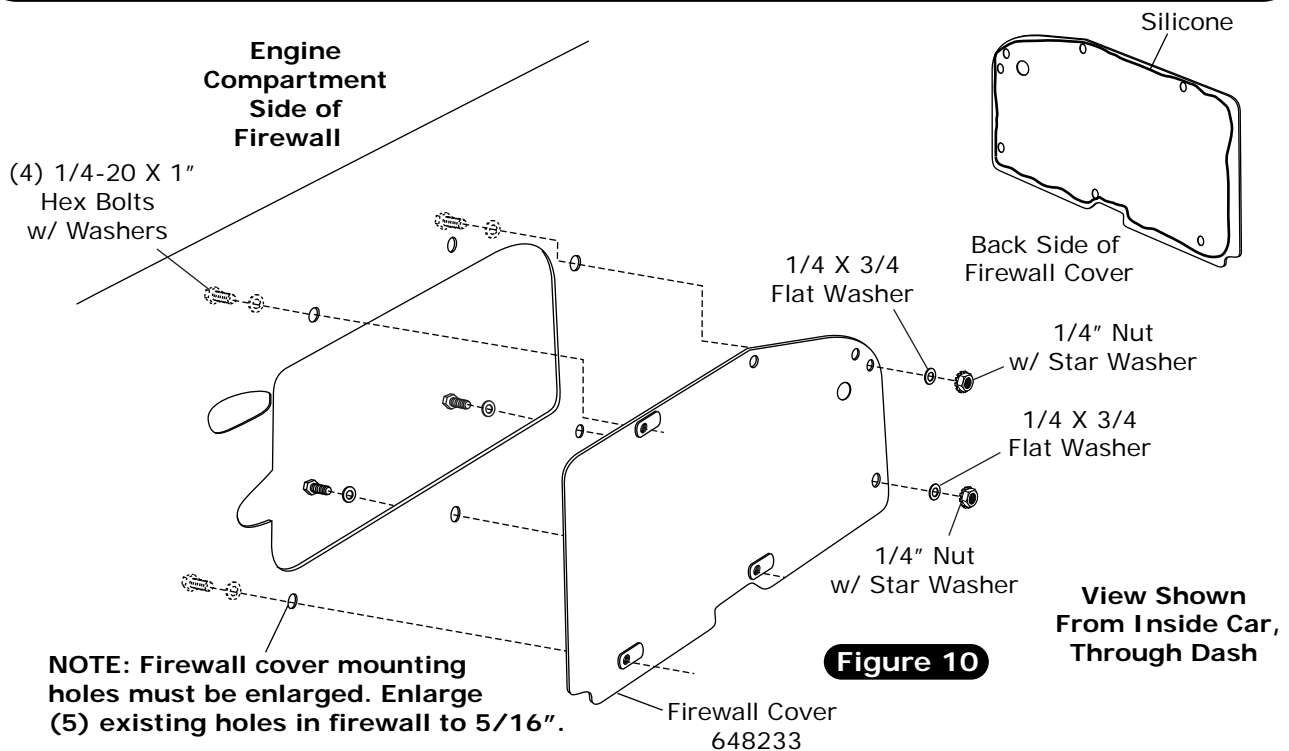

Figure 9b



Firewall Cover Installation

1. Enlarge (5) OEM firewall holes to 5/16" (See Figure 10, below).
2. Apply a 1/4" bead of silicone around the back side of the firewall cover as shown in Figure 10, below.
3. From inside the car, install firewall cover on firewall as shown in Figure 10, below. From the engine compartment, secure firewall cover to firewall using (4) 1/4-20 x 1" hex bolts, (5) flat washers and 1/4" nuts w/ star washers (See Figure 10, below).



Evaporator Bracket and Heater Hose Fitting Installation

1. On a workbench, install evaporator rear bracket and heater hose fittings with properly lubricated O-rings (See Figure 12, Page 12, and Figure 16, Page 15).
2. Install front mounting bracket on evaporator using (2) 1/4-20 x 1/2" hex bolts and tighten as shown in Figure 11, below.

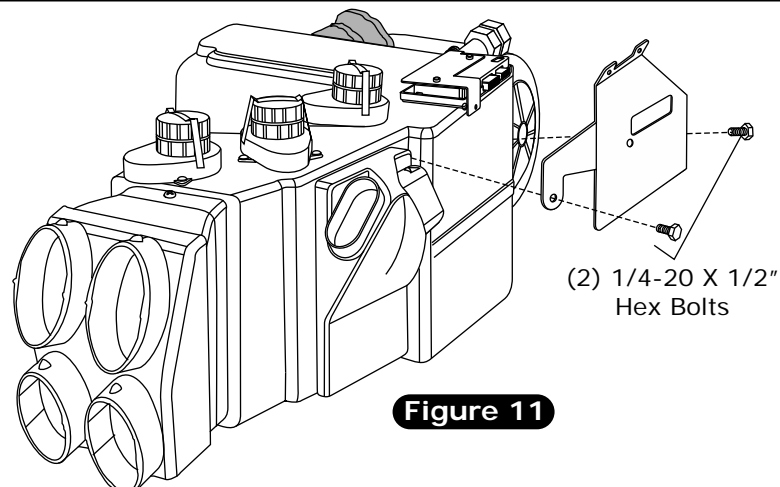



Evaporator Bracket and Heater Hose Fitting Installation (Cont.)

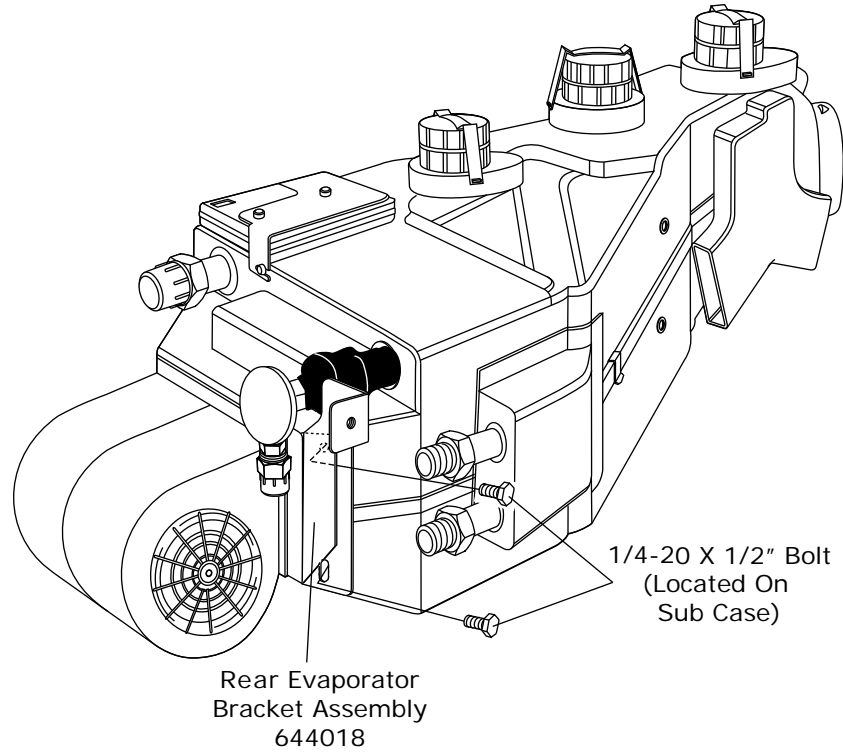
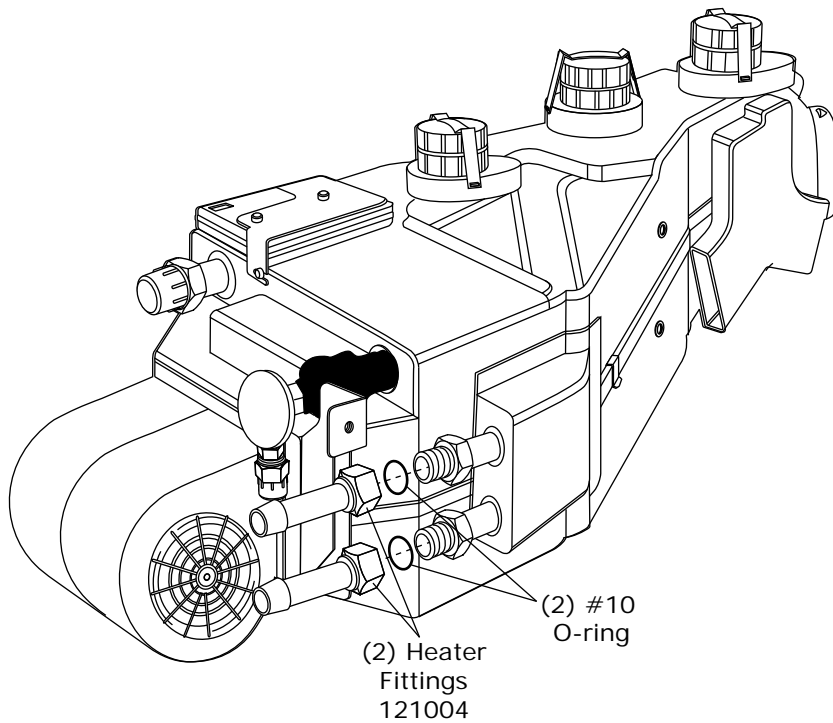

Figure 12





Kick Panel Modification

1. Disconnect pull cable assembly from kick panel (discard) (See Figure 13, below).
2. Modify passenger side kick panel as shown in Figure 13a, below.
3. Install 1/2" plastic plugs in kick panel (See Figure 13a, below).

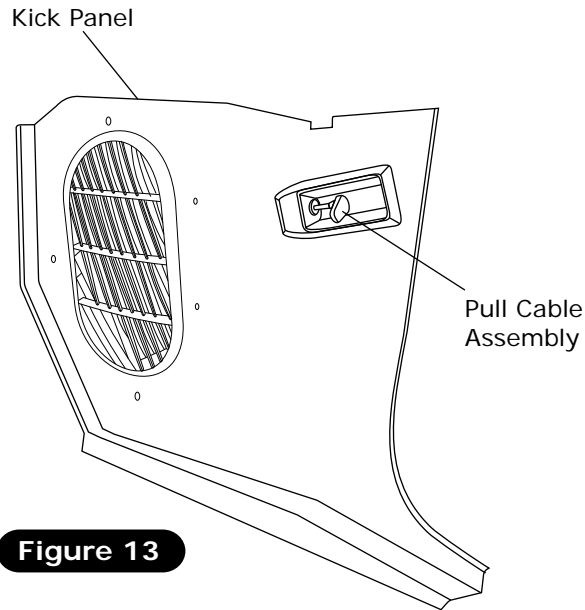

Figure 13

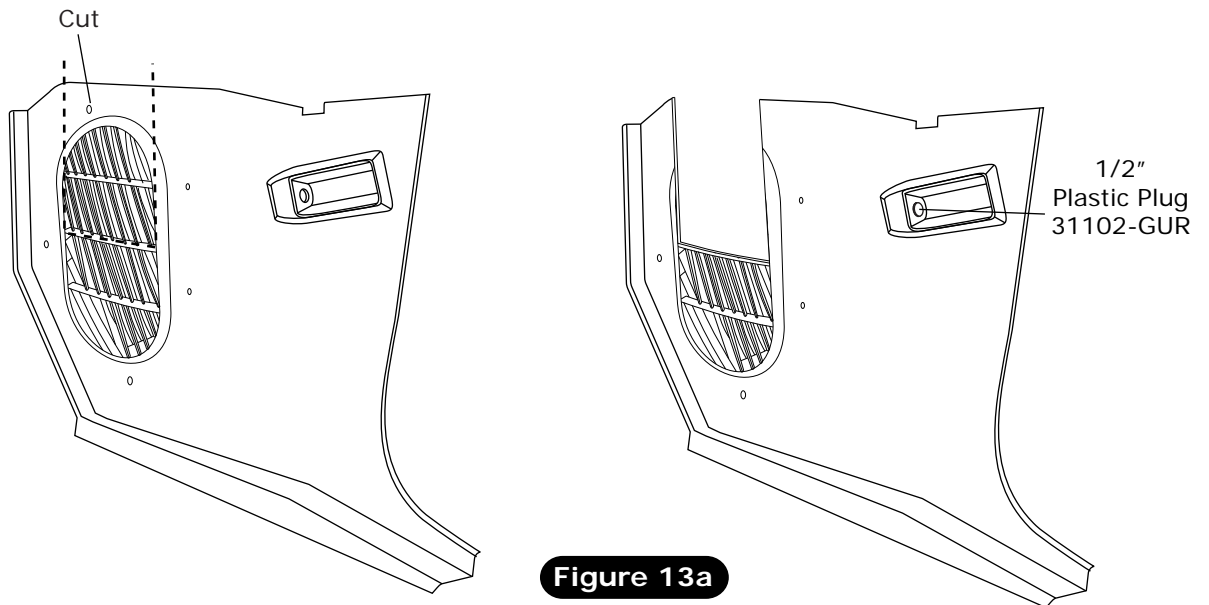
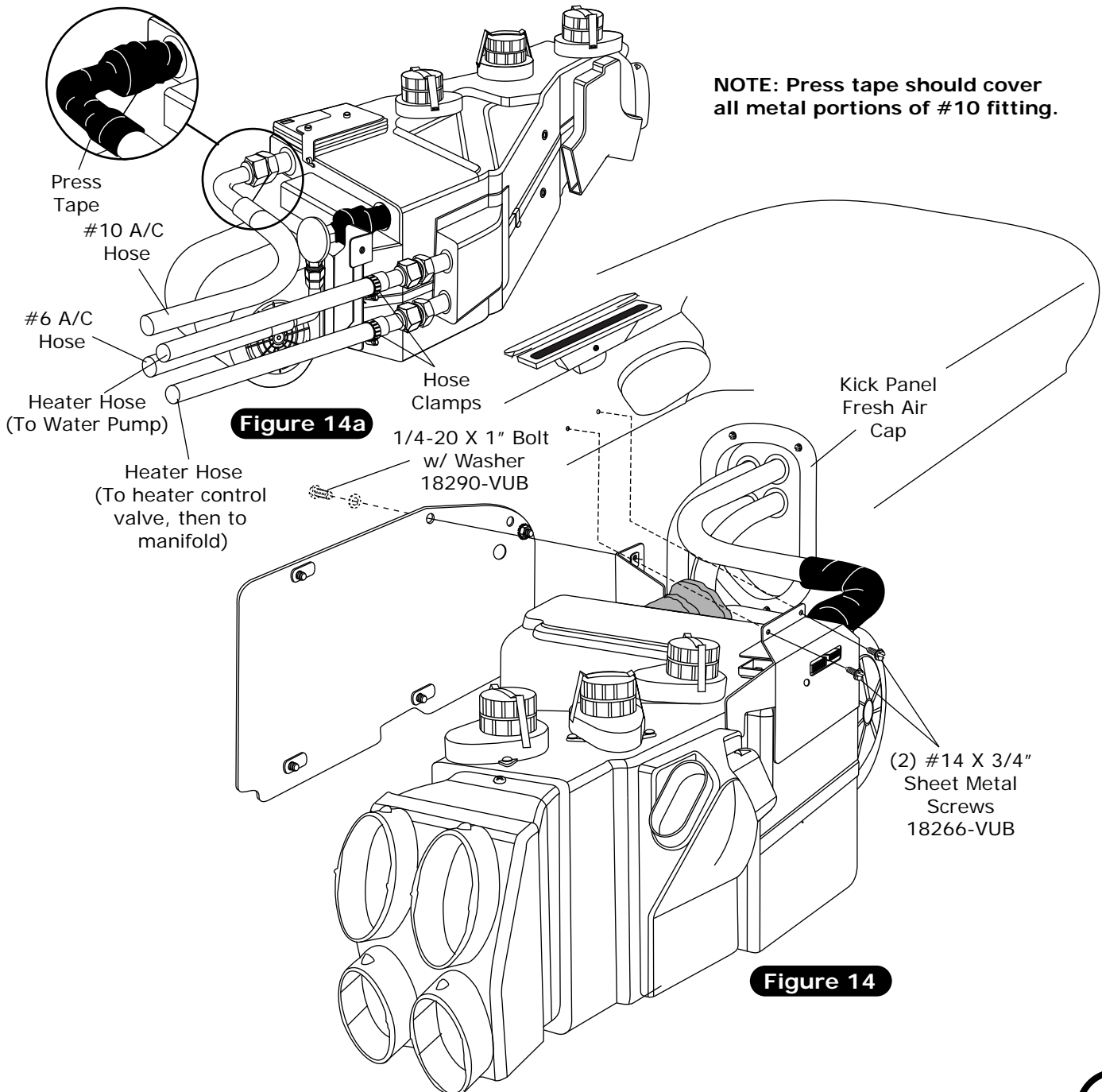

Figure 13a



Evaporator Installation

1. Install A/C & heater hoses as shown below.
2. Lift evaporator unit up under the dashboard (See Figure 14, below). Secure loosely to the firewall from the engine compartment side using a 1/4-20 x 1" bolt and washer (See Figure 14, below).
3. Using (2) #14 x 3/4" sheet metal screws, secure the front evaporator mounting bracket to the inner cowl (See Figure 14, below). Level, front to rear-side to side, mark & drill 3/16" holes.
4. Verify that the evaporator unit is level and square to the dash. Then tighten all mounting bolts. **NOTE: Tighten the bolt on firewall first, and then tighten the front mounting bracket screws.**





Drain Hose Installation

1. Locate evaporator drain on bottom of evaporator case.
2. In line with the drain, lightly make a mark on the firewall. Measure one inch down and drill a 5/8" hole through the firewall (See Figure 15, below).
3. Install drain hose to bottom of evaporator unit and route through firewall (See Figure 15, below).

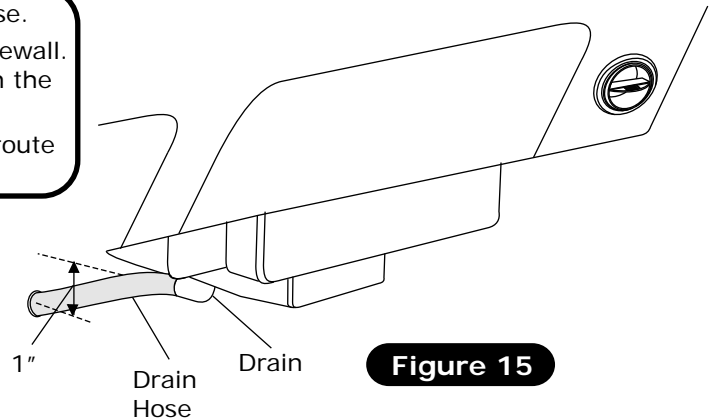
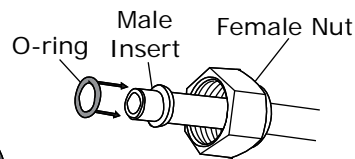
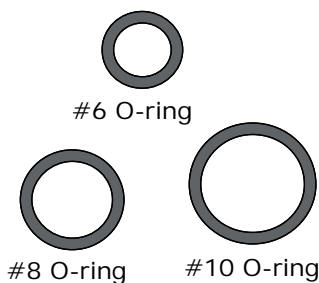

Figure 15

Lubricating O-rings



For a proper seal of fittings: Install supplied O-rings as shown, and lubricate with supplied oil.

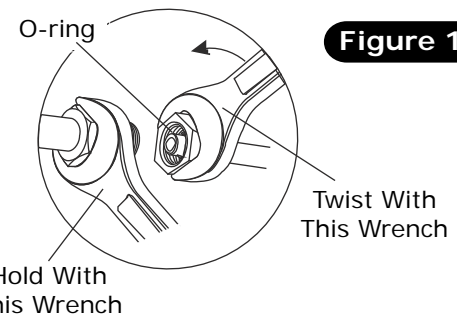
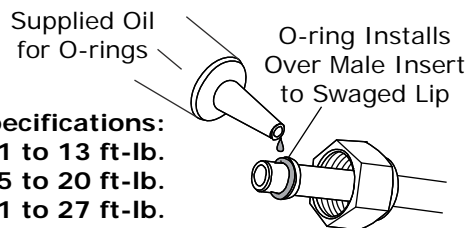

Figure 16

NOTE: Standard torque specifications:

- #6: 11 to 13 ft-lb.
- #8: 15 to 20 ft-lb.
- #10: 21 to 27 ft-lb.

A/C Hose Installation

Standard Hose Kit:

1. Locate the #8 compressor A/C hose. Lubricate (2) #8 O-rings (See Figure 16, above) and connect the 135° female fitting w/ 134a service port to the #8 discharge port on the compressor. Route the straight female fitting to the #8 condenser hardline coming through the core support (See Figure 17, Page 16). Tighten each fitting connection as shown in Figure 16, above.
2. Locate the #10 compressor A/C hose. Lubricate (2) #10 O-rings (See Figure 16, above) and connect the #10 135° female fitting w/134a service port to the #10 suction port on the compressor. Route the 90° female fitting to the #10 evaporator (See Figure 14a, Page 14, and Figure 17, Page 16). Tighten each fitting connection as shown in Figure 16, above.
3. Locate the #6 evaporator A/C hose. Lubricate (2) #6 O-rings (See Figure 16, above) and connect the 90° female fitting to the #6 hardline coming through the core support from drier. Route the 90° female fitting to the #6 evaporator (See Figure 14a, Page 14, and Figure 17, Page 16). Tighten each fitting connection as shown in Figure 16, above.

Modified A/C Hose Kit:

1. Refer to separate instructions included with modified hose kit.



Heater Hose & Heater Control Valve Installation

1. Route a piece of heater hose from the water pump to the top heater fitting of the heater core as shown in Figure 14a, Page 14, and Figure 17, below. Secure using hose clamps.
2. Route a piece of heater hose from the intake to the bottom heater fitting of the heater core as shown in Figure 14a, Page 14, and Figure 17, below. **NOTE: Install heater control valve in line with intake manifold (pressure side) heater hose, and secure using hose clamps as shown in Figure 17, below. Note proper flow direction.**

A/C & Heater Hose Routing

NOTE: Vintage Air Systems Require
(2) 5/8 Hose Nipples (Not Supplied)

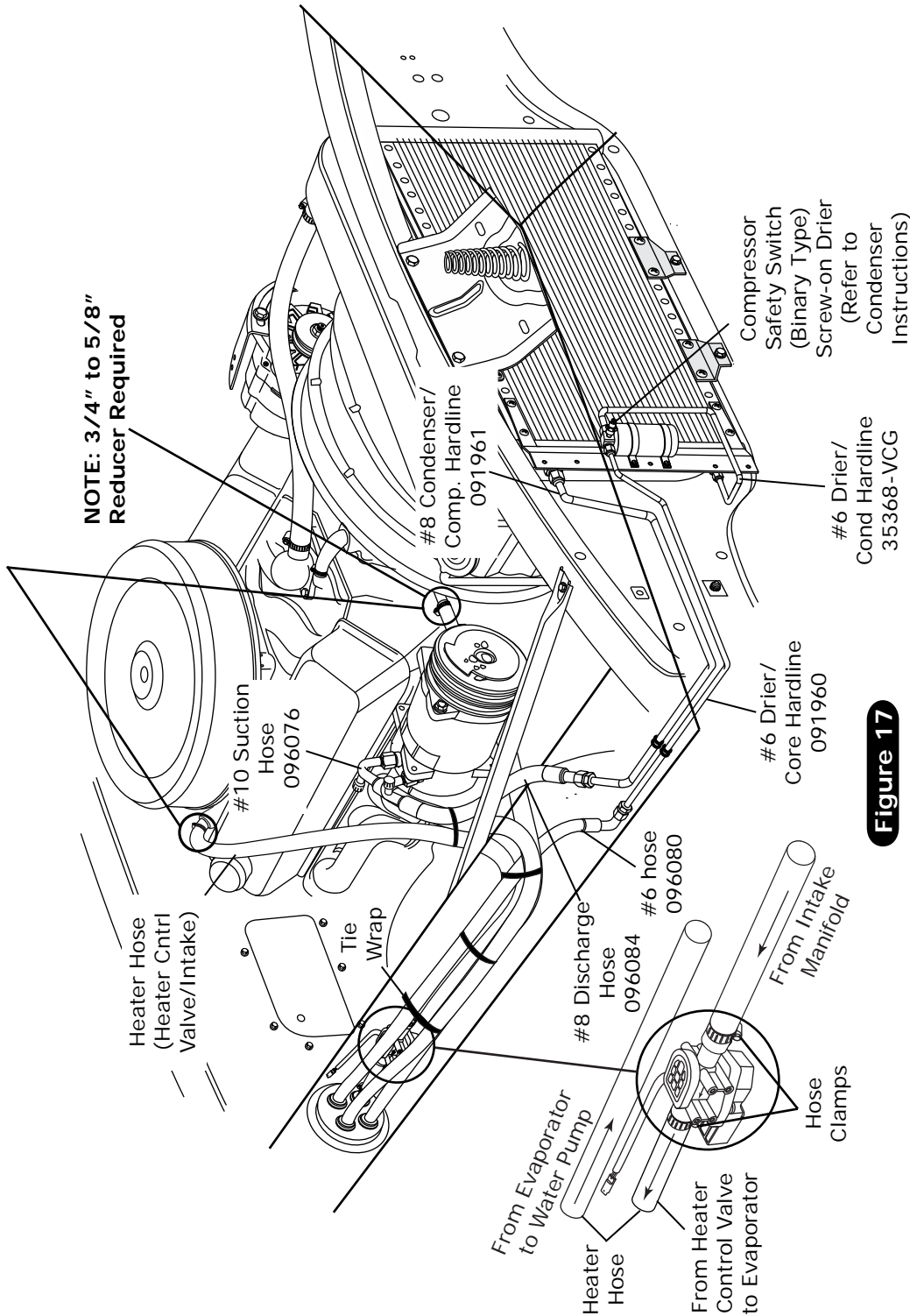

Figure 17



Final Steps

1. Install duct hoses as shown in Figure 21, Page 18.
2. Route A/C wires (12 volt/grounds/binary switch/heater valve) through 3/8" grommet as shown in Figure 18, below.
3. Install control panel assembly.
4. Plug the wiring harnesses into the ECU module on the sub case as shown in Figure 21, Page 18 (Wire according to wiring diagrams on Pages 19 and 20).
5. Remove (4) OEM screws from kick panel fresh air cap and reinstall kick panel using (4) #8 x 1" PH pan head screws (See Figure 19, below).
6. Install new glove box as shown in Figure 20, below.
7. Reinstall all previously removed items (battery tray & battery).
8. Fill radiator with at least a 50/50 mixture of approved antifreeze and distilled water. It is the owner's responsibility to keep the freeze protection at the proper level for the climate in which the vehicle is operated. Failure to follow antifreeze recommendations will cause heater core to corrode prematurely and possibly burst in A/C mode and/or freezing weather, voiding your warranty.
9. Double check all fittings, brackets and belts for tightness.
10. Vintage Air recommends that all A/C systems be serviced by a certified automotive air conditioning technician.
11. Evacuate the system for a minimum of 45 minutes prior to charging, and perform a leak check prior to servicing.
12. Charge the system to the capacities stated on Page 4 of this instruction manual.
13. See Operation of Controls procedures on Page 21.

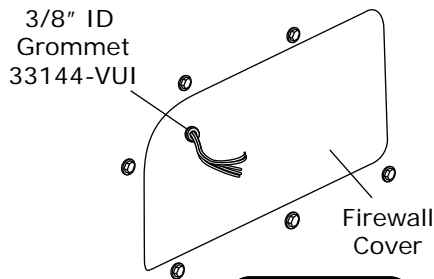

Figure 18

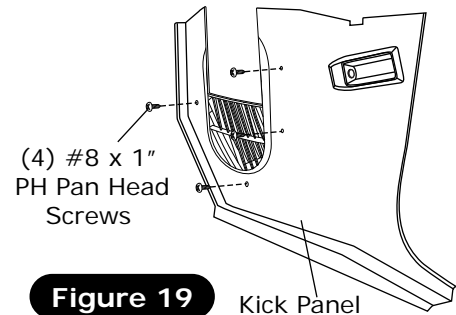
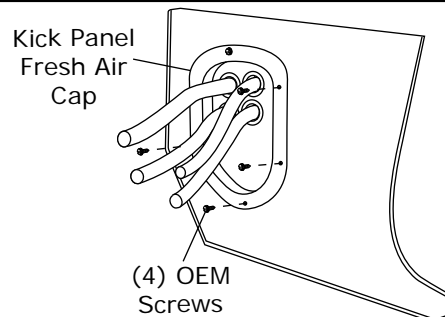

Figure 19

Glove Box Installation

1. The new glove box is made in (2) pieces for easy installation. Install (5) #8 U-nuts in glove box bottom.
2. Insert bottom half of new glove box, securing only with one OEM screw on each side through dash holes (See Figure 20, below).
3. Insert top half of glove box and fasten to bottom half using (4) #6 X 3/8" pan head screws (See Figure 20, below).
4. Install glove box door using (5) OEM screws as shown in Figure 20, below.

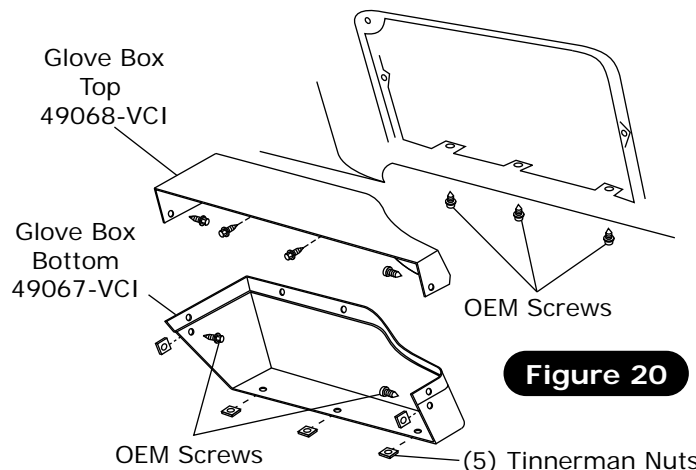

Figure 20



Control Panel & Duct Hose Routing

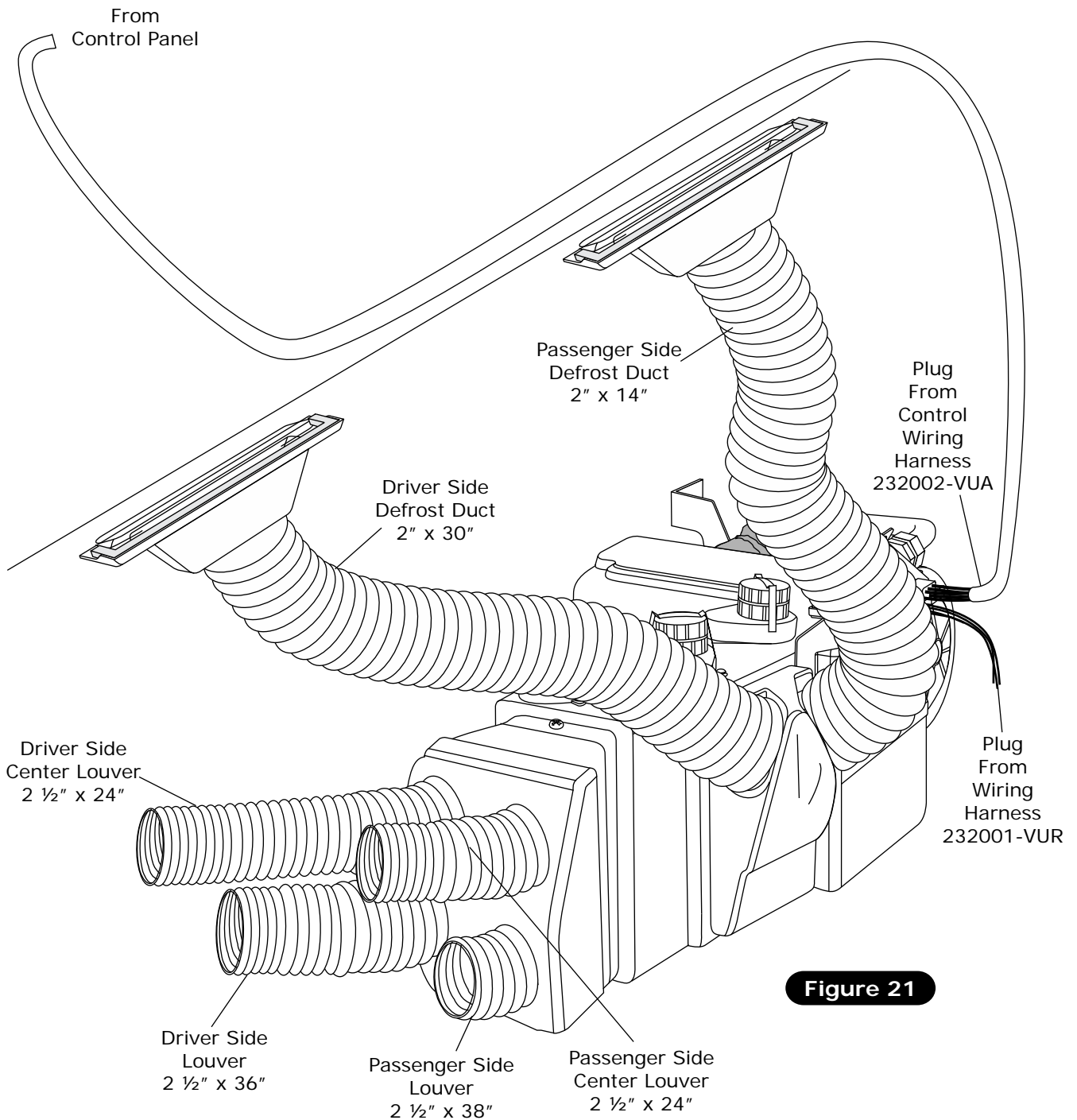
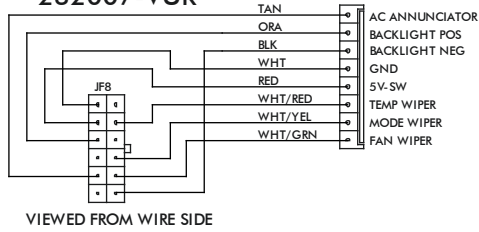

Figure 21



Wiring Diagram

232007-VUR



232002-VUA

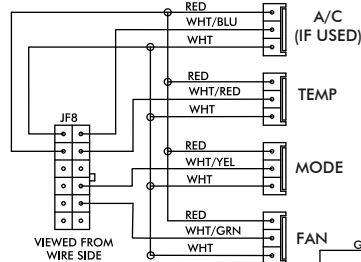

PROGRAM

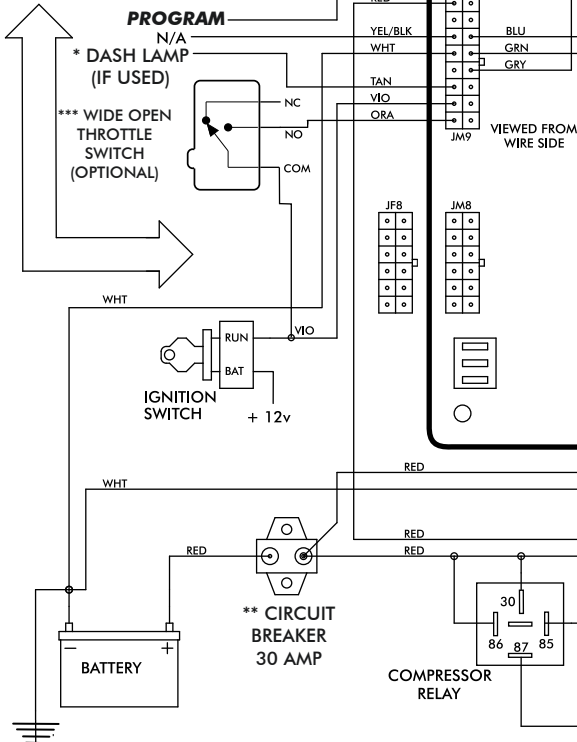

GEN IV ECU

GEN IV WIRING DIAGRAM
REV E, 10/6/2017

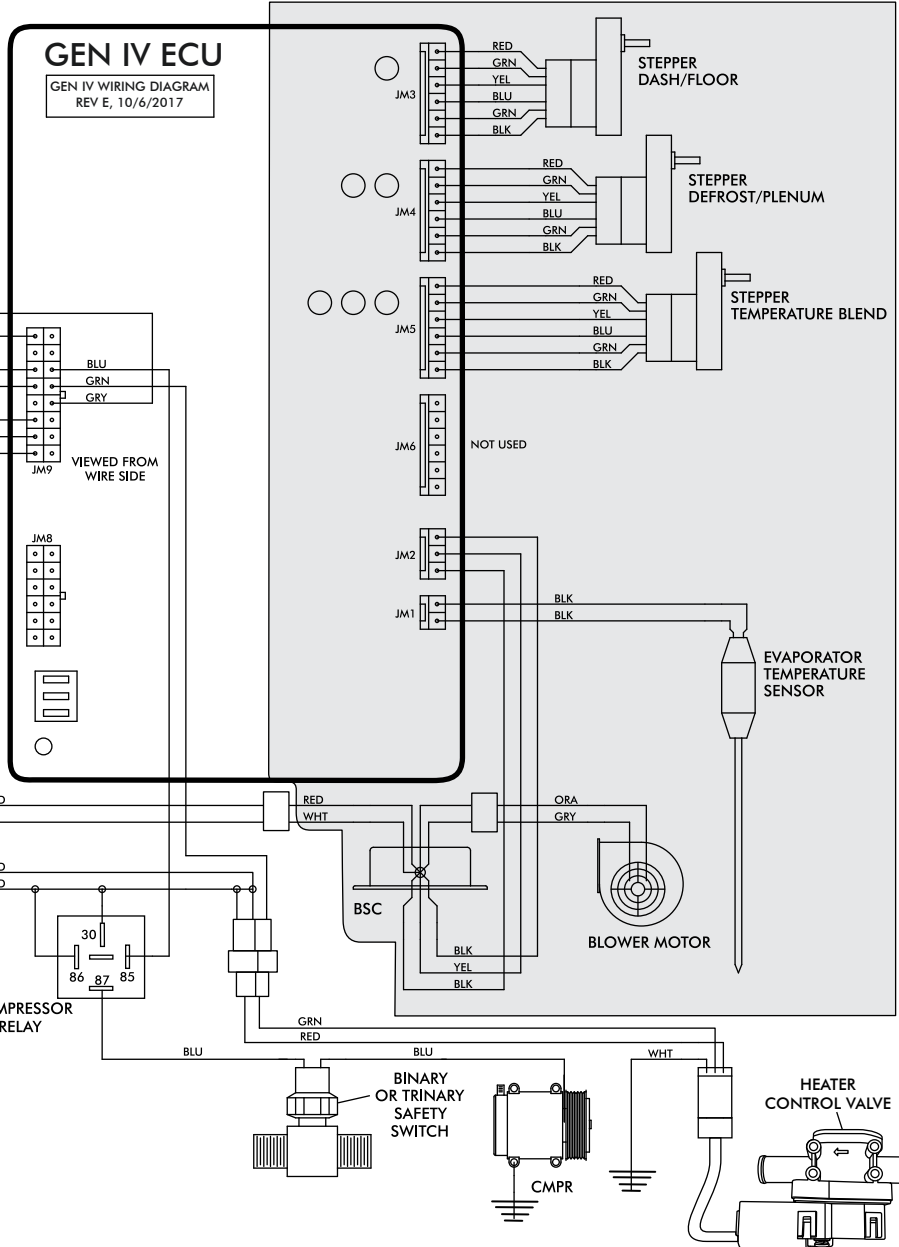

NOTE: = CHASSIS GROUND

* Dash lamp is used only with type 232007-VUR harness.

** Warning: Always mount circuit breaker as close to the battery as possible. (NOTE: Wire between battery and circuit breaker is unprotected and should be carefully routed to avoid a short circuit).

*** Wide open throttle switch contacts close only at full throttle, which disables A/C compressor.



Gen IV Wiring Connection Instruction

WIRING HARNESS

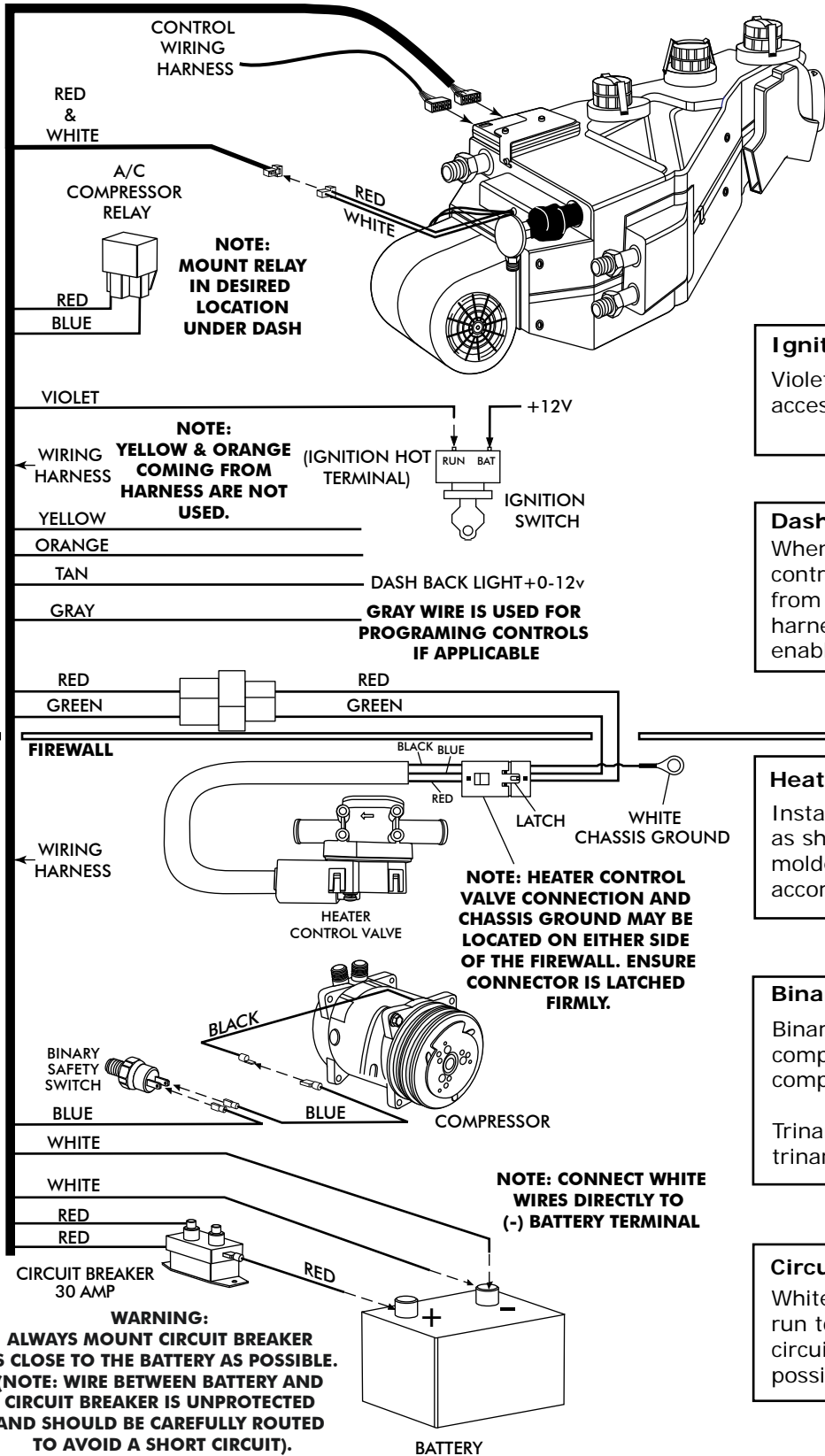

Ignition Switch:
Violet 12V ignition switch source (key on accessory) position must be switched.

Dash Light:
When using a Vintage Air-supplied control panel, connect the tan wire from the Gen IV evaporator wiring harness to the factory dash lights to enable panel backlighting.

Heater Control Valve:
Install with servo motor facing down, as shown. Note flow direction arrow molded into valve body and install accordingly.

Binary/Trinary & Compressor:
Binary: Connect as shown (typical compressor wiring). Be sure compressor body is grounded.
Trinary Switch: Connect according to trinary switch wiring diagram.

Circuit Breaker/Battery:
White **must** run to (-) battery. Red may run to (+) battery or starter. Mount circuit breaker as close to battery as possible.



Operation of Controls

On Gen IV systems with three lever/knob controls, the temperature control toggles between heat and A/C operations. To activate A/C, move the temperature lever/knob all the way to cold and then back it off to the desired vent temperature. For heat operation, move the temperature lever/knob all the way to hot and then adjust to the desired vent temperature. The blower will momentarily change speed, each time you toggle between operations, to indicate the change. **NOTE: For proper control panel function, refer to control panel instructions for calibration procedure.**

Blower Speed

This lever/knob controls blower speed, from OFF to HI.

Mode Control

This lever/knob controls the mode positions, from DASH to FLOOR to DEFROST, with a blend in between.

Temperature Control

This lever/knob controls the temperature, from HOT to COLD.

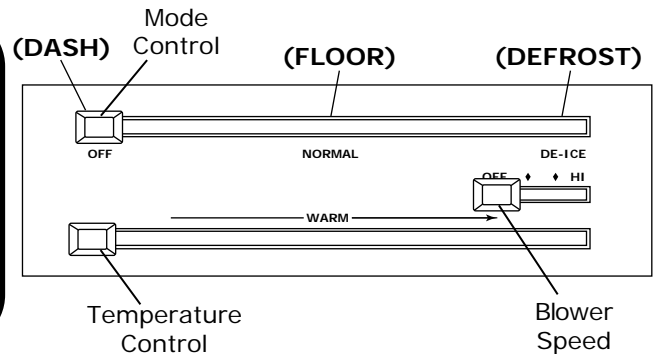

A/C Operation

Blower Speed

Adjust to desired speed.

Mode Control

Adjust to desired mode position (DASH position recommended).

Temperature Control

For A/C operation, adjust to coldest position to engage compressor (Adjust between HOT and COLD to reach desired temperature).

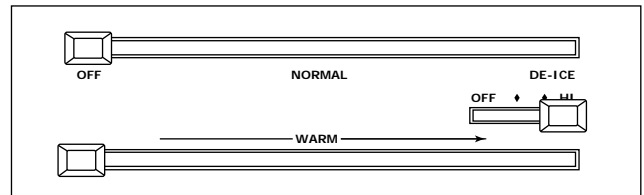

Heat Operation

Blower Speed

Adjust to desired speed.

Mode Control

Adjust to desired mode position (FLOOR position recommended).

Temperature Control

For maximum heating, adjust to hottest position (Adjust between HOT and COLD to reach desired temperature).

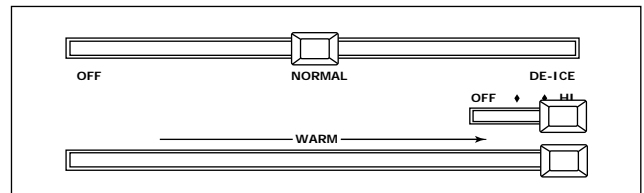

Defrost/De-fog Operation

Blower Speed

Adjust to desired speed.

Temperature Control

Adjust to desired temperature.

Mode Control

Adjust to DEFROST position for maximum defrost, or between FLOOR and DEFROST positions for a bi-level blend (Compressor is automatically engaged).

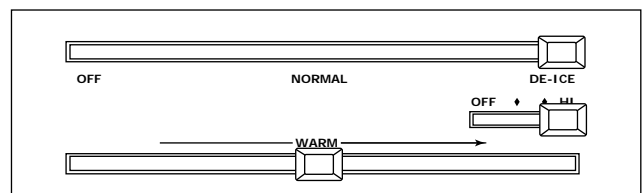



Troubleshooting Guide

Symptom	Condition	Checks	Actions	Notes
1a. Blower stays on high speed when ignition is on.	No other functions work.	Check for damaged pins or wires in control head plug.	Verify that all pins are inserted into plug. Ensure that no pins are bent or damaged in ECU.	Loss of ground on this wire renders control head inoperable. See blower switch check procedure.
	All other functions work.	Check for damaged ground wire (white) in control head harness. Check for damaged blower switch or potentiometer and associated wiring.	Verify continuity to chassis ground with white control head wire at various points.	
1b. Blower stays on high speed when ignition is on or off.		Unplug 3-wire BSC control connector from ECU. If blower shuts off, ECU is either improperly wired or damaged.	Be sure the small, 20 GA white ground wire is connected to the battery ground post. If it is, replace the ECU. Check to ensure that no BSC wiring is damaged or shorted to vehicle ground. The BSC operates the blower by ground side pulse width modulation switching. The positive wire to the blower will always be hot. If the "ground" side of the blower is shorted to chassis ground, the blower will run on HI.	No other part replacements should be necessary.
		Unplug 3-wire BSC control connector from ECU. If blower stays running, BSC is either improperly wired or damaged.	Replace BSC (This will require removal of evaporator from vehicle).	
2. Compressor will not turn on (All other functions work).	System is not charged.	System must be charged for compressor to engage.	Charge system or bypass pressure switch.	Danger: Never bypass safety switch with engine running. Serious injury can result. To check for proper pot function, check voltage at white/blue wire. Voltage should be between 0V and 5V, and will vary with pot lever position. Disconnected or faulty thermistor will cause compressor to be disabled.
	System is charged.	Check for faulty A/C potentiometer or associated wiring (not applicable to 3-pot controls).	Check continuity to ground on white control head wire. Check for 5V on red control head wire.	
		Check for disconnected or faulty thermistor.	Check 2-pin connector at ECU housing.	
		Check for faulty A/C potentiometer or associated wiring.	Repair or replace pot/control wiring.	
3. Compressor will not turn off (All other functions work).	System is charged.	Check for faulty A/C relay.	Replace relay.	Red wire at A/C pot should have approximately 5V with ignition on. White wire will have continuity to chassis ground. White/Blue wire should vary between 0V and 5V when lever is moved up or down.



Troubleshooting Guide (Cont.)

Symptom	Condition	Checks	Actions	Notes
4. System will not turn on, or runs intermittently.	Works when engine is not running; shuts off when engine is started (typically early Gen IV, but possible on all versions).	Noise interference from either ignition or alternator.	Install capacitors on ignition coil and alternator. Ensure good ground at all points. Relocate coil and associated wiring away from ECU and ECU wiring. Check for burned or loose plug wires.	Ignition noise (radiated or conducted) will cause the system to shut down due to high voltage spikes. If this is suspected, check with a quality oscilloscope. Spikes greater than 16V will shut down the ECU. Install a radio capacitor at the positive post of the ignition coil (see radio capacitor installation bulletin). A faulty alternator or worn out battery can also result in this condition.
		Verify connections on power lead, ignition lead, and both white ground wires.	Check for positive power at heater valve green wire and blower red wire. Check for ground on control head white wire.	
	Will not turn on under any conditions.	Verify battery voltage is greater than 10 volts and less than 16.	Verify proper meter function by checking the condition of a known good battery.	
	5. Loss of mode door function.	No mode change at all.	Check for damaged mode switch or potentiometer and associated wiring.	
Partial function of mode doors.		Check for obstructed or binding mode doors. Check for damaged stepper motor or wiring.		
6. Blower turns on and off rapidly.		Battery voltage is at least 12V.	Check for at least 12V at circuit breaker.	Ensure all system grounds and power connections are clean and tight.
	Battery voltage is less than 12V.	Check for faulty battery or alternator.	Charge battery.	
7. Erratic functions of blower, mode, temp, etc.		Check for damaged switch or pot and associated wiring.	Repair or replace.	
	8. When ignition is turned on, blower momentarily comes on, then shuts off. This occurs with the blower switch in the OFF position.		This is an indicator that the system has been reset. Be sure the red power wire is on the battery post, and not on a switched source. Also, if the system is pulled below 7V for even a split second, the system will reset.	Run red power wire directly to battery.



Packing List

Evaporator Kit (561168)

No.	Qty.	Part No.	Description
1.	1	744013	Gen IV Evap Sub Case w/90 Defrost w/204 ECU
2.	1	781179	Accessory Kit 1969 Firebird wo A/C

Checked By: _____
 Packed By: _____
 Date: _____

①

Gen IV Evaporator Sub Case
 w/ 90 Defrost w/ 204 ECU
 744013

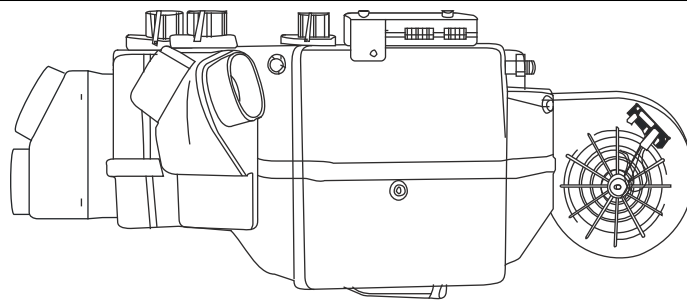

②

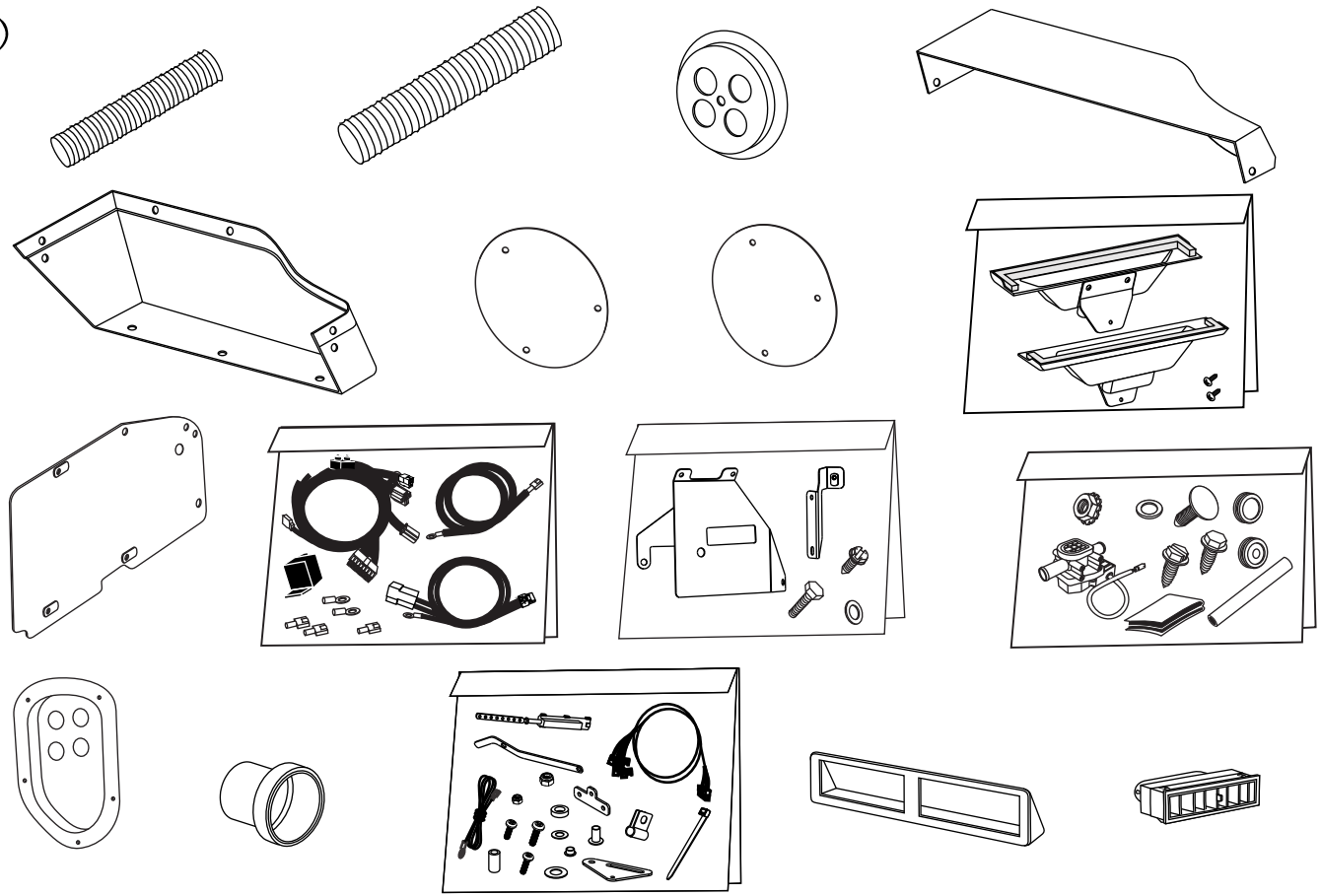

Accessory Kit
 781179

**NOTE: Images may not depict actual parts and quantities.
 Refer to packing list for actual parts and quantities.**