



an ISO 9001: 2008 Registered Company

1969 CUTLASS

WITHOUT FACTORY AIR
561070

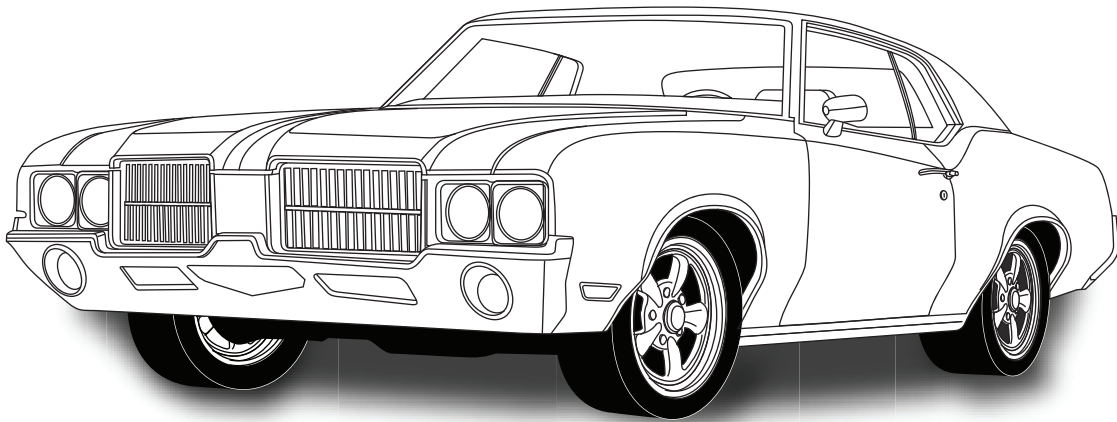



Table of Contents

PAGES

1. COVER
2. TABLE OF CONTENTS
3. PACKING LIST / PARTS DISCLAIMER
4. INFORMATION PAGE
5. WIRING NOTICE
6. ENGINE COMPARTMENT, CONDENSER ASSEMBLY, COMPRESSOR & BRACKET
& PULLEYS
FIGURE 1
7. PASSENGER COMPARTMENT
FIGURES 2 & 2a
8. KICK PANEL MODIFICATION
FIGURES 3, 4 & 4a
9. DEFROST DUCT INSTALLATION & DRIVER AND PASSENGER SIDE HOSE ADAPTER
INSTALLATION
FIGURES 5, 5a & 6
10. FRESH AIR COVER INSTALLATION & KICK PANEL FRESH AIR CAP INSTALLATION
FIGURES 7, 8, 8a & 8b
11. FIREWALL COVER INSTALLATION & EVAPORATOR INSTALLATION
FIGURES 9 & 10
12. BRACKET INSTALLATION CONT.
FIGURE 11
13. EVAPORATOR INSTALLATION CONT.
FIGURES 12 & 13
14. DRAIN HOSE INSTALLATION LUBRICATING O-RINGS, A/C HOSE INSTALLATION
FIGURES 14 & 15
15. A/C & HEATER HOSE ROUTING
FIGURE 16
16. FINAL STEPS
FIGURES 17 & 18
17. CONTROL PANEL & DUCT HOSE ROUTING
FIGURES 19 & 20
18. WIRING DIAGRAM
19. GEN IV WIRING CONNECTION INSTRUCTIONS
20. OPERATION OF CONTROLS
21. TROUBLESHOOTING INFORMATION
22. TROUBLESHOOTING INFORMATION CONT.
23. KICK PANEL TEMPLATE
24. EVAPORATOR KIT PACKING LIST



EVAPORATOR KIT
561070

No.	QTY.	PART No.	DESCRIPTION
1.	1	744004-VUE	GEN IV 4 VENT EVAP. SUB CASE w/ 204
2.	1	784069	1969 CUTLASS wo AC ACC. KIT

**** BEFORE BEGINNING INSTALLATION OPEN ALL PACKAGES AND CHECK CONTENTS OF SHIPMENT. PLEASE REPORT ANY SHORTAGES DIRECTLY TO VINTAGE AIR WITHIN 15 DAYS. AFTER 15 DAYS, VINTAGE AIR WILL NOT BE RESPONSIBLE FOR MISSING OR DAMAGED ITEMS.**

1

**GEN IV 4 VENT
EVAP SUB CASE
w/204 ECU
744004-VUE**

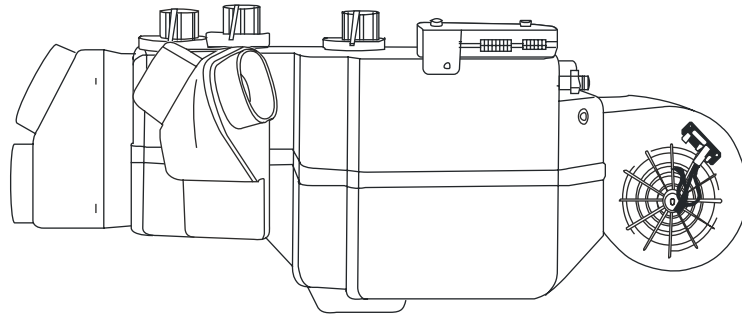

2

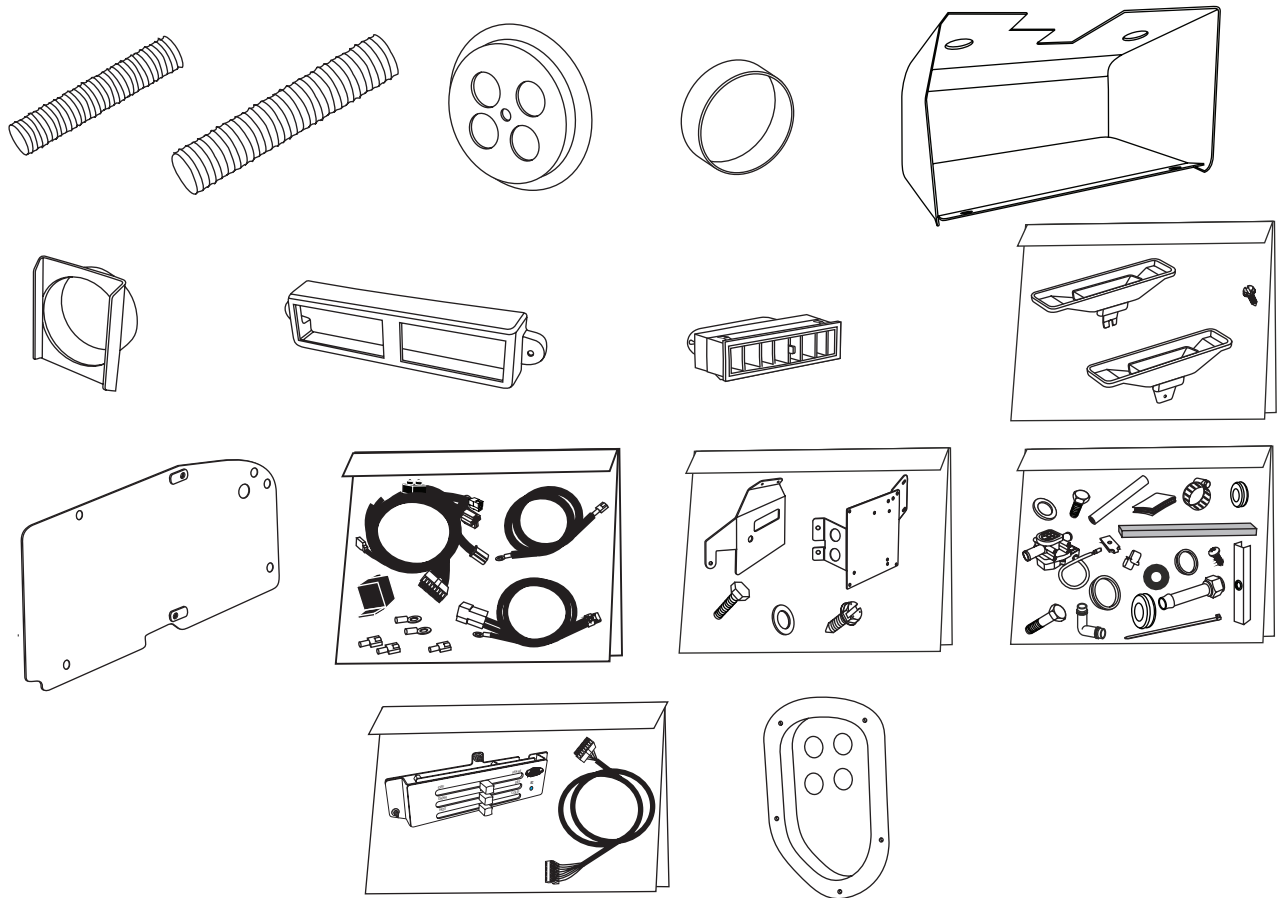

**ACCESSORY KIT
784069**

**NOTE: IMAGES MAY NOT DEPICT ACTUAL PARTS AND QUANTITIES.
REFER TO PACKING LIST FOR ACTUAL PARTS AND QUANTITIES.**

3



Important Notice—Please Read

For Maximum System Performance, Vintage Air Recommends the Following:

Heater Hose (Not Included With This Kit):

Heater hose may be purchased from Vintage Air (Part# 31800-VUD) or your local parts retailer. Routing and required length will vary based on installer preference.

Bolts Passing Through Cowl and/or Firewall:

To ensure a watertight seal between the passenger compartment and the vehicle exterior, for all bolts passing through the cowl and/or firewall, Vintage Air recommends coating the threads with silicone prior to installation.

Safety Switches:

Your Vintage Air system is equipped with a binary pressure safety switch. A binary switch disengages the compressor clutch in cases of extreme low pressure conditions (Refrigerant Loss) or excessively high head pressure (406 PSI) to prevent compressor damage or hose rupture. A trinary switch combines Hi/Lo pressure protection with an electric fan operation signal at 254 PSI, and should be substituted for use with electric fans. Compressor safety switches are extremely important since an A/C system relies on refrigerant to circulate lubricant.

Service Info:

Attention: The following system components are capped: Compressor, evaporator, condenser & drier. Caps may be under pressure with dry nitrogen. Be careful removing caps. Do not remove caps prior to installation. Removing caps prior to installation will cause components to collect moisture and lead to premature failure and reduced performance.

Evacuate the system for 35-45 minutes with system components (Drier, compressor, evaporator and condenser) at a temperature of at least 85° F. On a cool day, the components can be heated with a heat gun OR by running the engine with the heater on before evacuating. Leak check and charge to specifications.

Vintage Air Systems Are Designed to Operate With R134a Refrigerant Only! Use of Any Other Refrigerants Is a Fire Hazard and Could Damage Either Your Air Conditioning System or Your Vehicle.

Use of Any Other Refrigerants Will Void All Warranties of the Air Conditioning System and Components. Use of the Proper Type and Amount of Refrigerant Is Critical to Proper System Operation. Vintage Air Recommends Our Systems Be Charged By Weight With a Quality Charging Station or Scale.

Refrigerant Capacity for Vintage Air Systems:

(For other systems, consult manufacturer's guidelines)

R134a System

Charge with 1.8 lbs. (1 lb., 12 oz.) of refrigerant.

Lubricant Capacities:

New Vintage Air-supplied Sanden Compressor: No additional oil needed (Compressor is shipped with proper oil charge).

All Other Compressors: Consult manufacturer (Some compressors are shipped dry and will need oil added).



Important Wiring Notice—Please Read

Some Vehicles May Have Had Some or All of Their Radio Interference Capacitors Removed. There Should Be a Capacitor Found At Each of the Following Locations:

- 1. On the positive terminal of the ignition coil.**
- 2. If there is a generator, on the armature terminal of the generator.**
- 3. If there is a generator, on the battery terminal of the voltage regulator.**

Most alternators have a capacitor installed internally to eliminate what is called "whining" as the engine is revved. If whining is heard in the radio, or just to be extra cautious, a radio interference capacitor can be added to the battery terminal of the alternator.

It is also important that the battery lead is in good shape and that the ground leads are not compromised. There should be a heavy ground from the battery to the engine block, and additional grounds to the body and chassis.

If these precautions are not observed, it is possible for voltage spikes to be present on the battery leads. These spikes come from ignition systems, charging systems, and from switching some of the vehicle's other systems on and off. Modern computer-operated equipment can be sensitive to voltage spikes on the power leads, which can cause unexpected resets, strange behavior, and/or permanent damage.

Vintage Air strives to harden our products against these types of electrical noise, but there is a point where a vehicle's electrical system can be degraded so much that nothing can help.

Radio interference capacitors should be available at most auto and truck parts suppliers. They typically are cylindrical in shape, a little over an inch long, a little over a half inch in diameter, and they have a single lead coming from one end of the cylinder with a terminal on the end of the wire, as well as a mounting clip which is screwed into a good ground on the vehicle. The specific value of the capacitance is not too significant in comparison to ignition capacitors that are matched with the coil to reduce pitting of the points.

- Care must be taken, when installing the compressor lead, not to short it to ground. The compressor lead must not be connected to a condenser fan or to any other auxiliary device. Shorting to ground or connecting to a condenser fan or any other auxiliary device may damage wiring, the compressor relay, and/or cause a malfunction.
- When installing ground leads on Gen IV systems, the blower control ground and ECU ground must be connected directly to the negative battery post.
- For proper system operation, the heater control valve must be connected to the ECU.



BEFORE STARTING THE INSTALLATION, CHECK THE FUNCTION OF THE VEHICLE (HORN, LIGHTS, ETC.) FOR PROPER OPERATIONS. STUDY THE INSTRUCTIONS, ILLUSTRATIONS, & DIAGRAMS.

ENGINE COMPARTMENT

REMOVE THE FOLLOWING

- DISCONNECT BATTERY
 - BATTERY, BATTERY TRAY (RETAIN)
 - DRAIN RADIATOR
 - OEM BLOWER MOTOR ASSEMBLY
- TO REMOVE THE OEM BLOWER MOTOR ASSEMBLY (UNDER HOOD) AND THE OEM HEATER ASM (UNDER DASH) THE FACTORY MANUAL INDICATES DOING THE FOLLOWING, **REMOVE RIGHT INNER FENDER.**
- OEM HEATER HOSES (DISCARD). SEE FIGURE 1.
 - OEM HEATER WIRING/VACUUM HARNESS MOLDED GROMMET. SEE FIGURE 1.

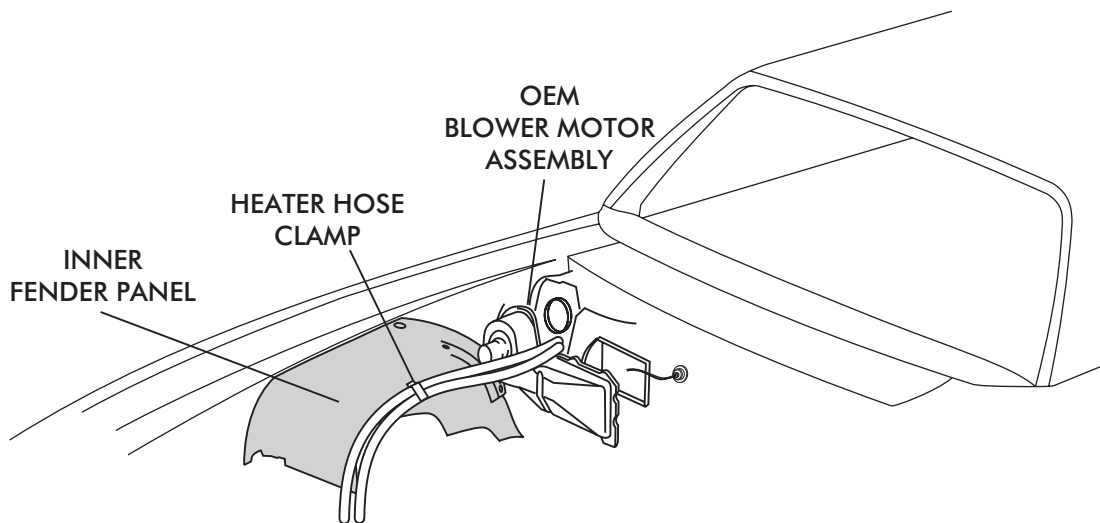

FIGURE 1

CONDENSER ASSEMBLY & INSTALLATION

- REFER TO SEPARATE INSTRUCTIONS INCLUDED WITH THE CONDENSER KIT TO INSTALL THE CONDENSER.
- BINARY SWITCH INSTALLATION (REFER TO CONDENSER INSTRUCTIONS)

COMPRESSOR & BRACKETS

- REFER TO SEPARATE INSTRUCTIONS INCLUDED WITH THE BRACKET KIT TO INSTALL THE COMPRESSOR BRACKET.

PULLEYS

- IN MOST INSTANCES THE BELT LENGTHS WILL REMAIN THE SAME.



PASSENGER COMPARTMENT

REMOVE THE FOLLOWING:

- REMOVE GLOVE BOX DOOR (RETAIN) AND GLOVE BOX (DISCARD) (SEE FIGURE 2 BELOW).
- DISCONNECT ALL WIRE AND CABLES FROM CONTROL PANEL AND RADIO.
- REMOVE RADIO (RETAIN) AND CONTROL PANEL (DISCARD).
- ALL DUCTING FROM OEM LOUVERS. SEE FIGURE 2 BELOW.
- OEM DEFROST DUCT ASSEMBLY BY STRAIGHTENING 4 METAL TABS. SEE FIGURE 2 BELOW.
- OEM A/C HEATER ASM (DISCARD). SEE FIGURE 2 BELOW.
- INSTALL CENTER LOUVER ASM IN DASH AS SHOWN IN FIGURE 2a.

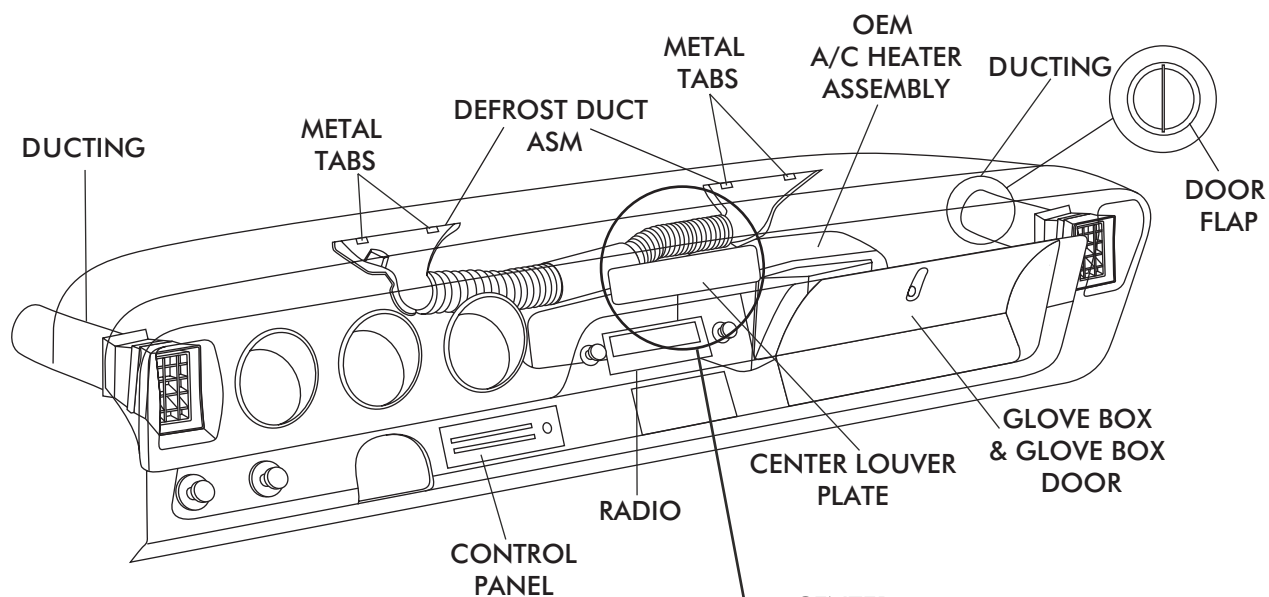

FIGURE 2

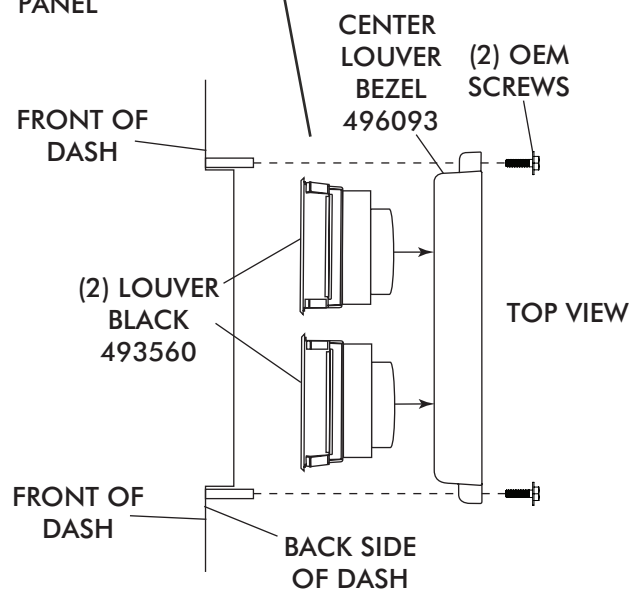
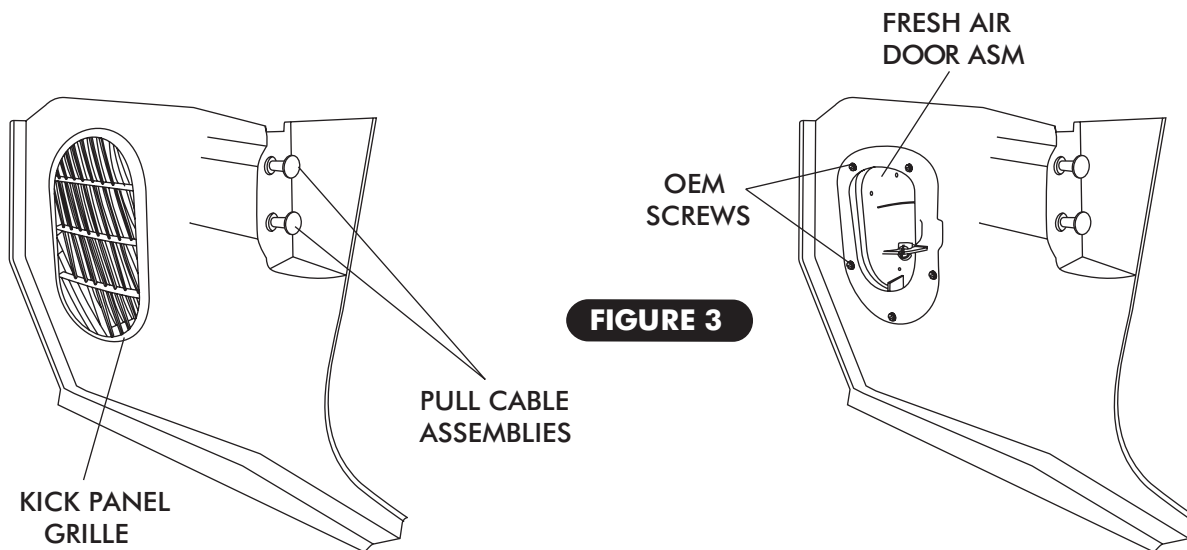

FIGURE 2a



KICK PANEL MODIFICATION

- REMOVE KICK PANEL GRILLE (DISCARD). REMOVE KICK PANEL BY REMOVING (5) OEM SCREWS FROM THE FRESH AIR DOOR ASM. DISCONNECT AND DISCARD PULL CABLE ASSEMBLIES FROM THE KICK PANEL. SEE FIGURE 3, BELOW.



- INSTALL 1/2" PLASTIC PLUGS TO FILL THE HOLES LEFT FROM THE REMOVAL OF THE PULL CABLE ASM. SEE FIGURE 4, BELOW.
- CUT FRESH AIR DOOR ASM AS SHOWN IN FIGURE 4, BELOW.
- USE TEMPLATE PROVIDED ON PAGE 23.
- PLACE TEMPLATE ON KICK PANEL AS SHOWN IN FIGURE 4a.

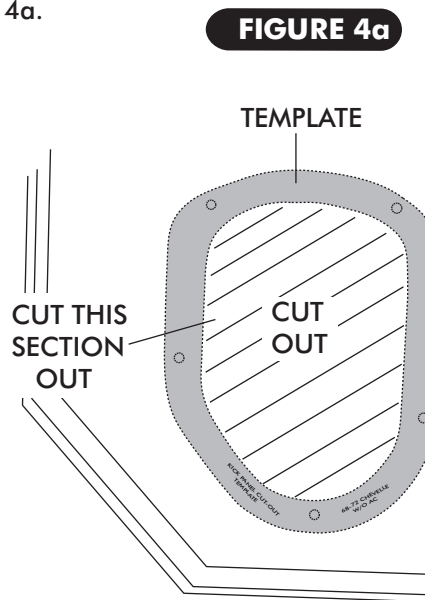
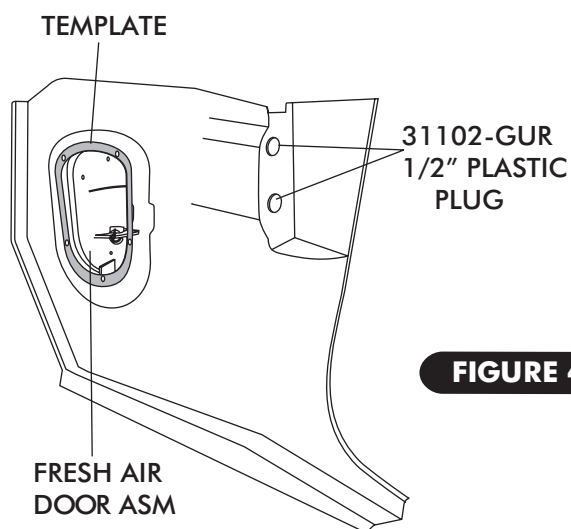



DEFROST DUCT INSTALLATION

- INSTALL DEFROST DUCTS UNDER DASH AND ALIGN WITH OEM OPENING. INSTALL THE PASSENGER SIDE DEFROST DUCT TO COWL USING #10 x 1/2" SHEET METAL SCREWS. SEE FIGURE 5 BELOW. **NOTE: DRIVER SIDE DEFROST DUCT INSTALLS BEHIND STEERING COLUMN BRACE AND SECURES USING STEERING COLUMN OEM BOLT AS SHOWN BELOW.**
- INSTALL ASTRO VENT CAP WITH "S" CLIPS AS SHOWN IN FIGURE 5a, BELOW.

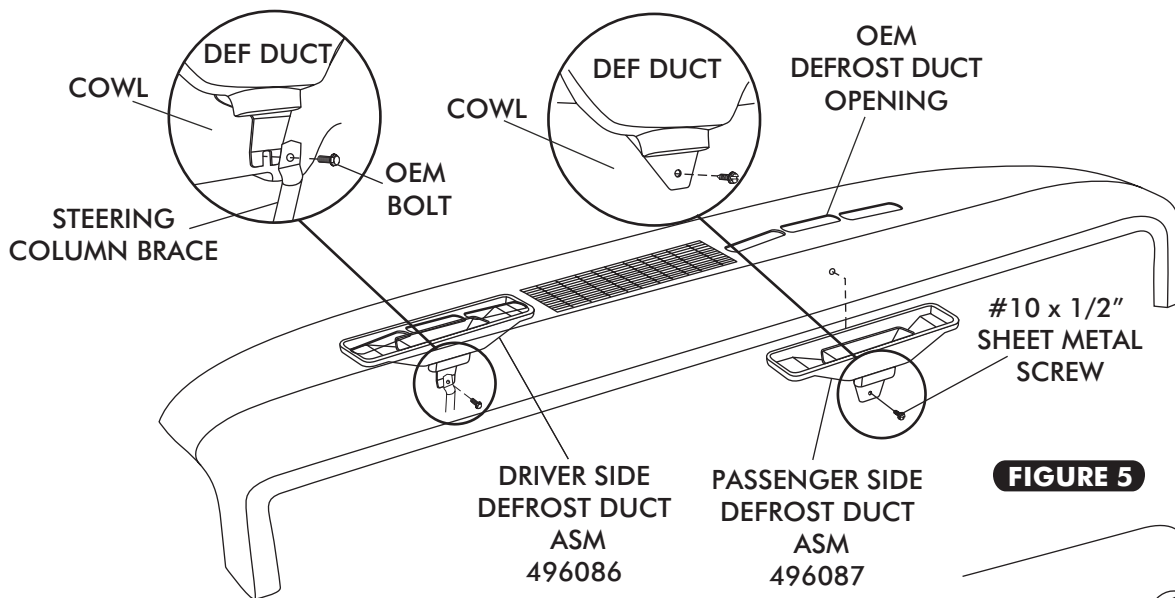

FIGURE 5

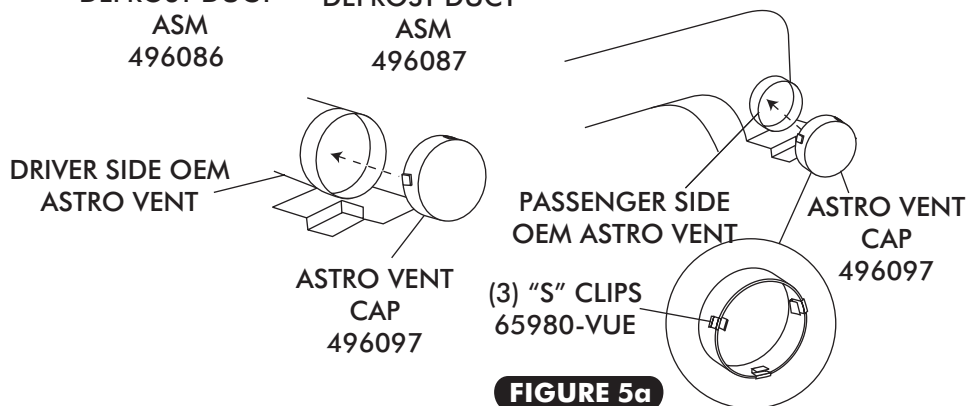

FIGURE 5a

DRIVER AND PASSENGER SIDE HOSE ADAPTER INSTALLATION

- INSTALL S-CLIPS ON HOSE ADAPTERS AS SHOWN IN FIGURE 6, BELOW.
- INSTALL ADAPTER ON DRIVER AND PASSENGER SIDE OEM LOUVERS. SEE FIGURE 6, BELOW.

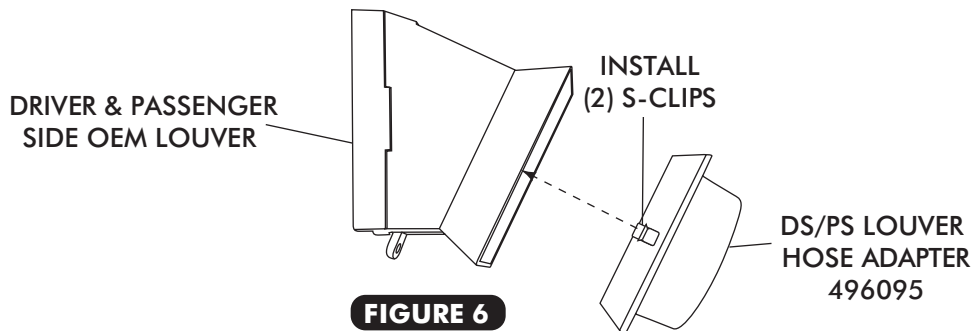

FIGURE 6



FRESH AIR COVER INSTALLATION

- ❑ INSTALL 7/8" PLUG IN OEM HOLE ON FIREWALL. SEE FIGURE 7.
- ❑ INSTALL (4) GROMMETS IN FRESH AIR CAP. SEE FIGURE 7, BELOW.
- ❑ APPLY A 1/4" BEAD OF SILICONE AROUND THE BACK SIDE OF THE FRESH AIR CAP AS SHOWN IN FIGURE 7, BELOW.
- ❑ ATTACH FRESH AIR CAP TO FIREWALL USING A 1/4-20 x 1 1/2" BOLT AND WASHER. SEE FIGURE 7, BELOW. **NOTE: FRESH AIR CAP INSTALLS ON ENGINE SIDE OF FIREWALL.**

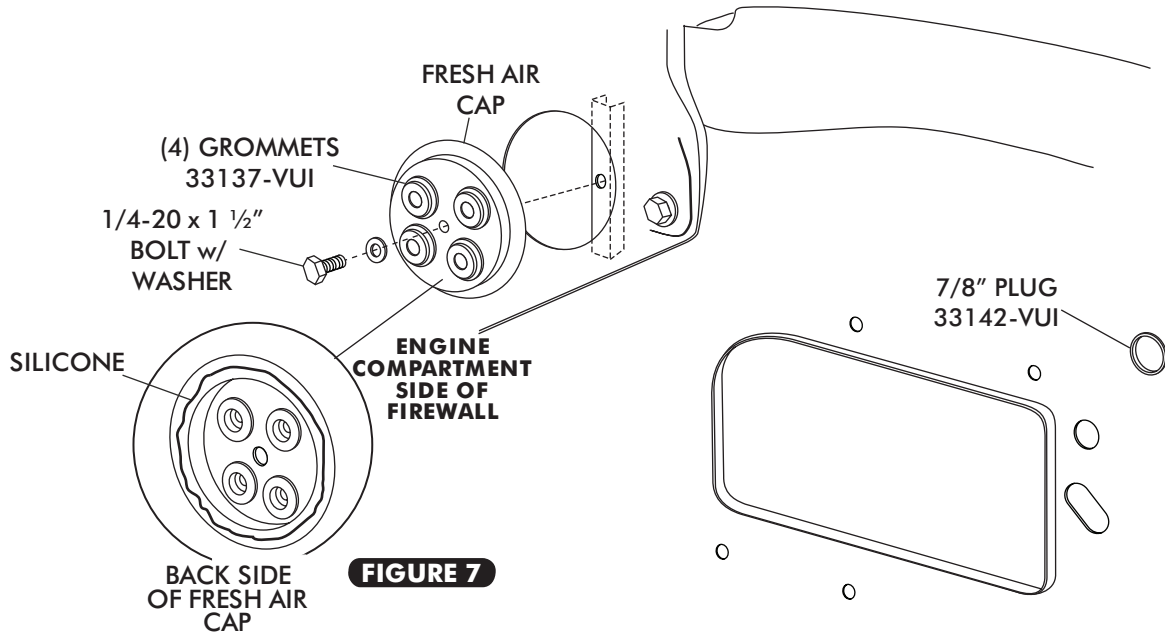

FIGURE 7

KICK PANEL FRESH AIR CAP INSTALLATION

- ❑ INSTALL (4) GROMMETS IN KICK PANEL FRESH AIR CAP. SEE FIGURE 8a, BELOW.
- ❑ ROUTE A/C AND HEATER HOSE THROUGH FRESH AIR CAP AND KICK PANEL FRESH AIR CAP AS SHOWN IN FIGURE 8 AND 8b, BELOW.
- ❑ APPLY A 1/4" BEAD OF SILICONE AROUND THE BACK SIDE OF KICK PANEL FRESH AIR CAP AS SHOWN IN FIGURE 8a, BELOW.
- ❑ SECURE KICK PANEL FRESH AIR CAP USING (5) #8 x 1 1/4" PH PAN HEAD SCREWS AS SHOWN IN FIGURE 8b, BELOW.

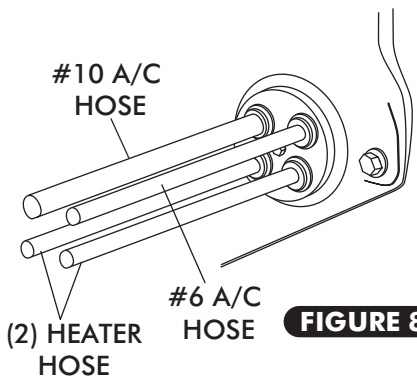

FIGURE 8

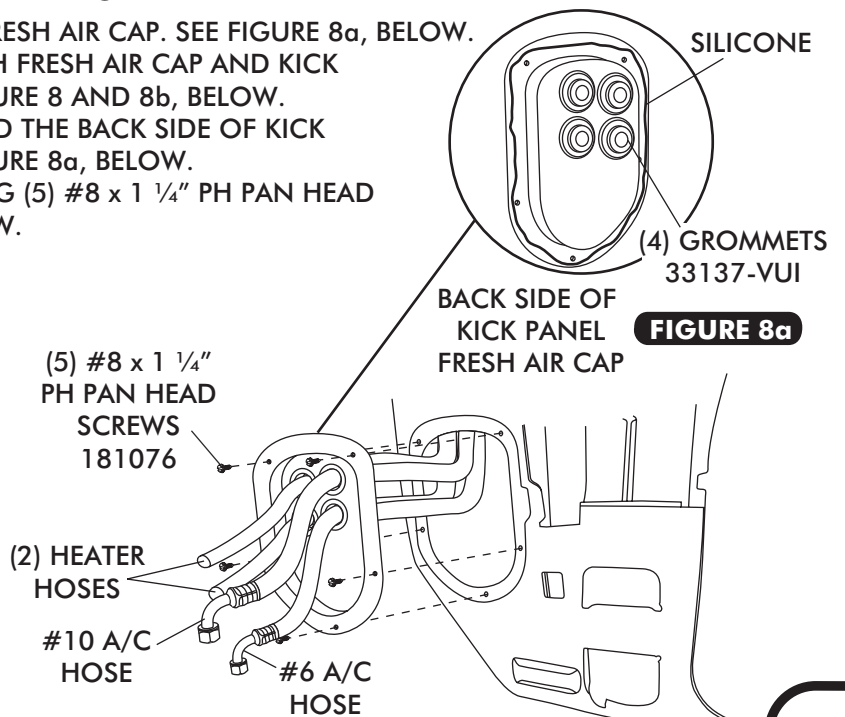

FIGURE 8a

FIGURE 8b



FIREWALL COVER INSTALLATION

- APPLY A 1/4" BEAD OF SILICONE AROUND THE BACK SIDE OF THE FIREWALL COVER AS SHOWN IN FIGURE 9, BELOW.
- FROM INSIDE THE CAR, INSTALL FIREWALL COVER ON FIREWALL USING (3) 1/4-20 x 1" HEX BOLTS, (3) FLAT WASHERS AND (1) 1/4-20 NUT WITH STAR WASHER. SEE FIGURE 9, BELOW.

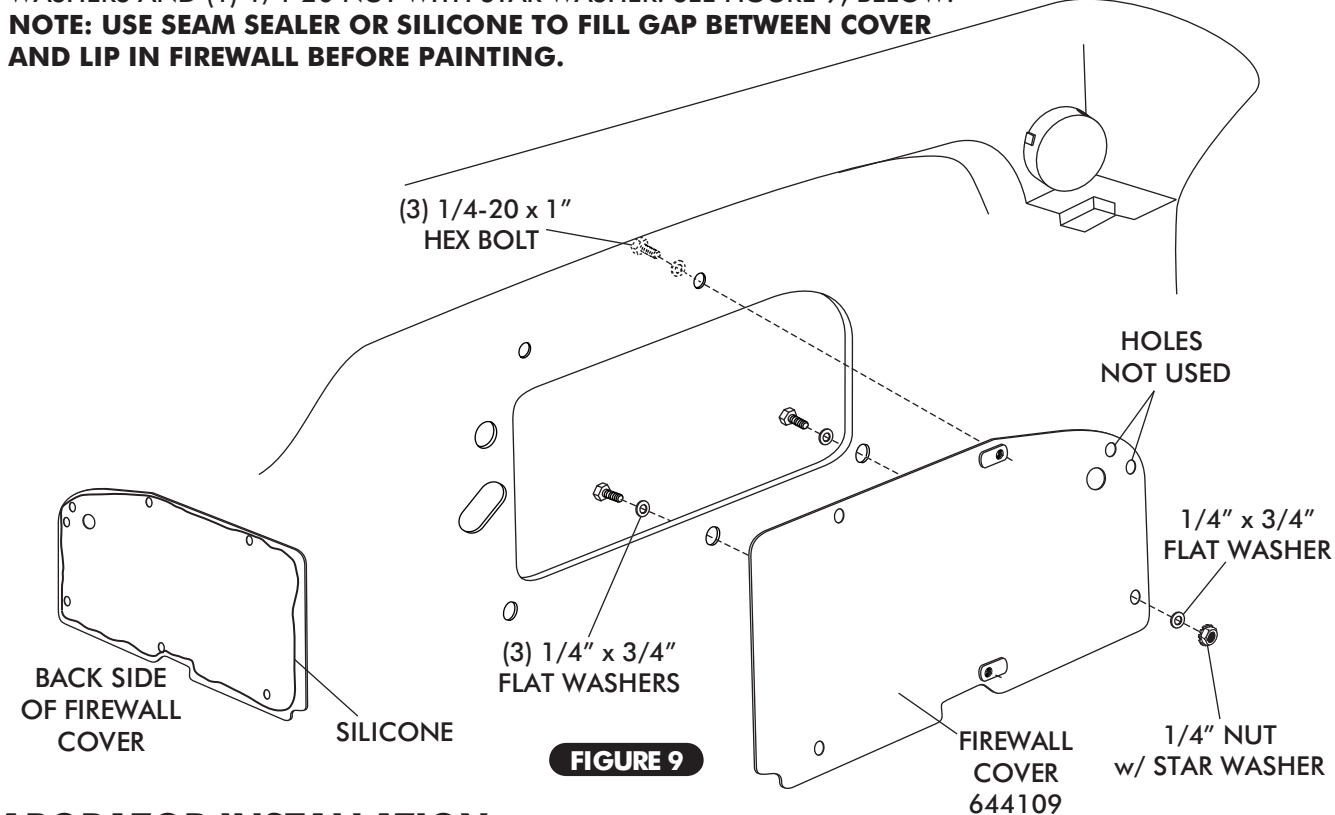

FIGURE 9

EVAPORATOR INSTALLATION

- ON A WORKBENCH, INSTALL (2) HEATER FITTINGS WITH PROPERLY LUBRICATED O-RINGS (SEE FIGURE 15, PAGE 14, AND FIGURE 11 PAGE 12).
- INSTALL EVAPORATOR FRONT & REAR MOUNTING BRACKETS ON EVAPORATOR USING (6) 1/4-20 x 1/2" HEX BOLTS AND TIGHTEN AS SHOWN IN FIGURE 10, BELOW & FIGURE 11, PAGE 12.
- LAY EVAPORATOR SUB CASE ON PASSENGER SIDE FLOOR BOARD. INSTALL A/C & HEATER HOSE ON EVAPORATOR AS SHOWN IN FIGURE 15, PAGE 14, AND FIGURE 12, PAGE 13.
- **NOTE: WRAP THE #10 FITTING CONNECTIONS WITH PRESS TAPE. SEE FIGURE 12, PAGE 13.**

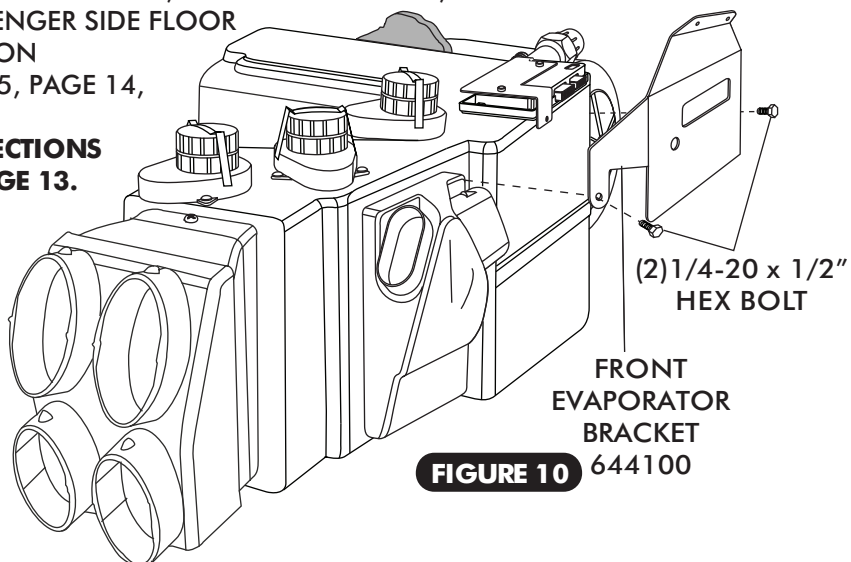
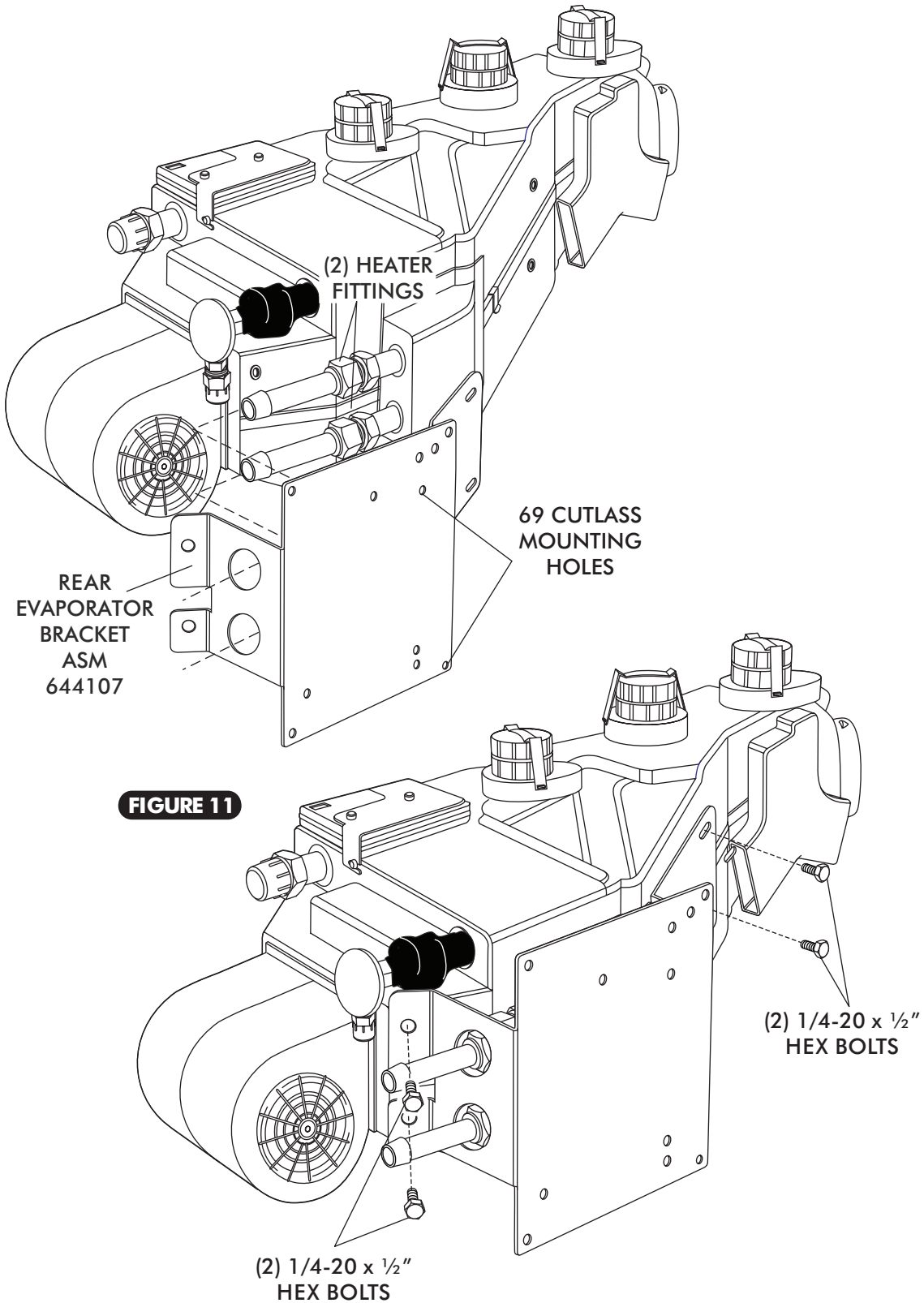

FIGURE 10



BRACKET INSTALLATION CONT.





EVAPORATOR INSTALLATION CONT.

- LIFT EVAPORATOR UNIT UP UNDER THE DASHBOARD. SECURE LOOSELY TO THE FIREWALL FROM THE ENGINE COMPARTMENT SIDE USING (2) 1/4-20 x 1 1/4" HEX BOLTS AND FLAT WASHERS. SEE FIGURE 13.
- VERIFY THAT EVAPORATOR UNIT IS LEVEL AND SQUARE TO THE DASH.
- SECURE THE FRONT EVAPORATOR MOUNTING BRACKET TO COWL. USING BRACKET AS TEMPLATE DRILL (2) 3/16" HOLES IN COWL. SECURE WITH (2) #14 x 3/4" HEX SHEET METAL SCREWS SEE FIGURE 13 BELOW.
- THEN TIGHTEN ALL MOUNTING BOLTS. **NOTE: TIGHTEN THE BOLT ON FIREWALL FIRST, THEN THE FRONT MOUNTING BRACKET.**

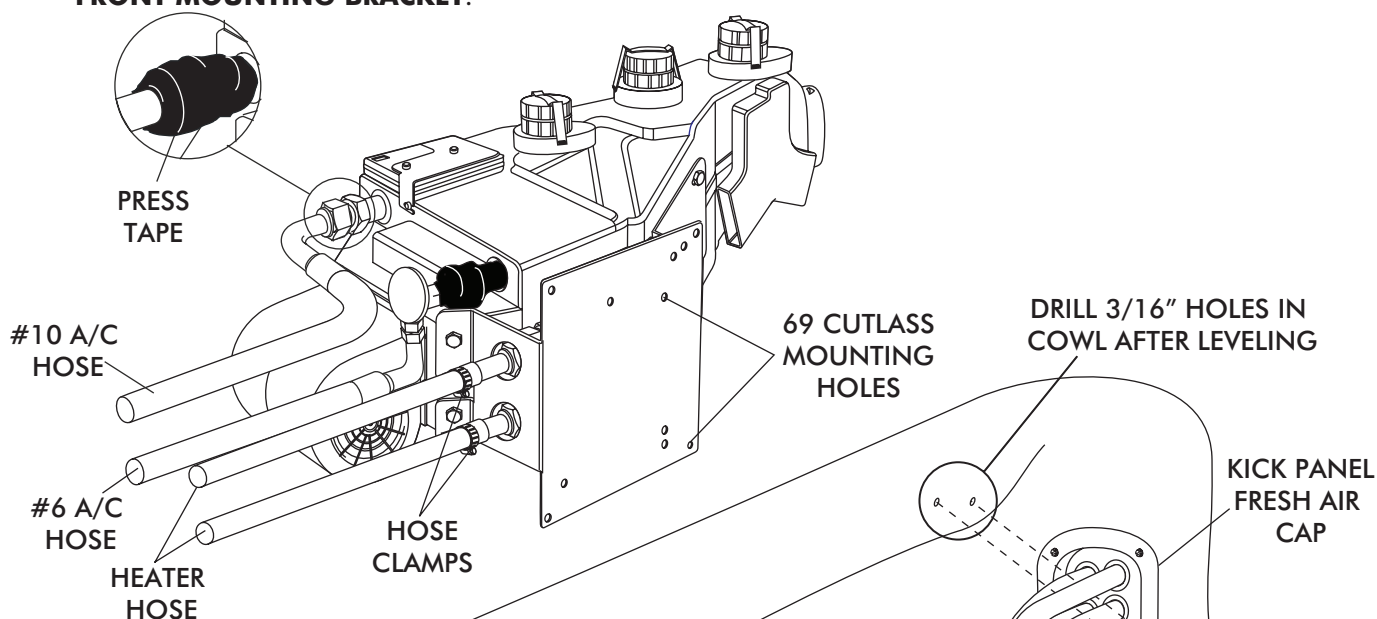

FIGURE 12

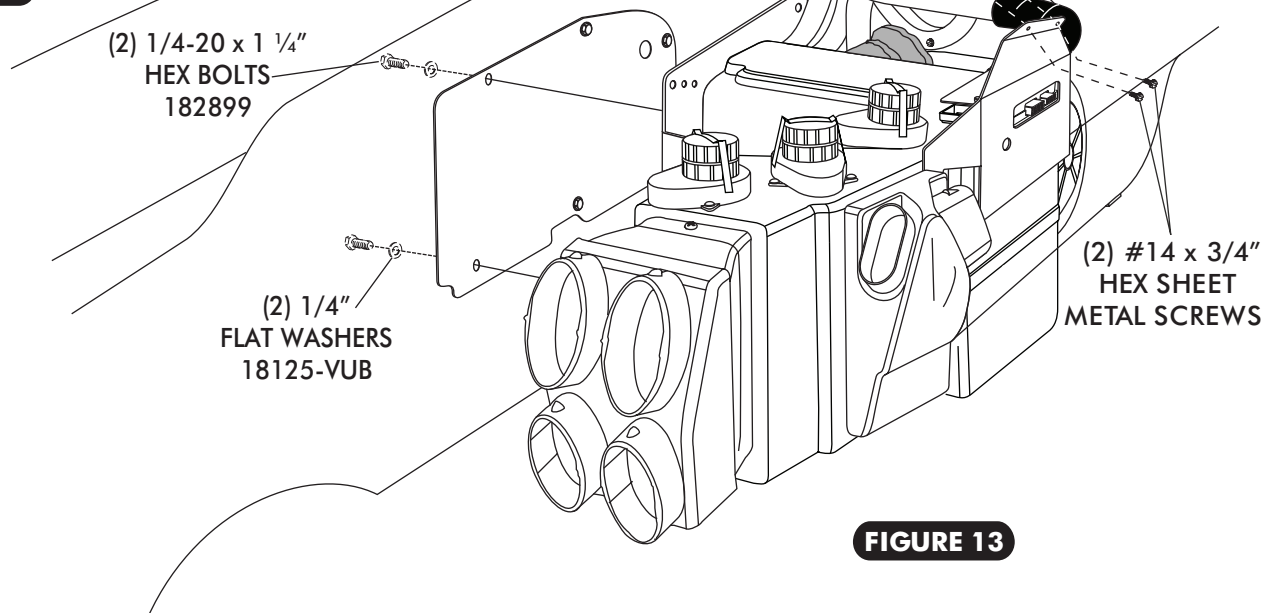

FIGURE 13



DRAIN HOSE INSTALLATION

- LOCATE EVAPORATOR DRAIN ON BOTTOM OF EVAPORATOR CASE.
- IN LINE WITH DRAIN, LIGHTLY MAKE A MARK ON THE FIREWALL. MEASURE 1" DOWN AND 2 1/2" TO THE LEFT AND DRILL A 5/8" HOLE THROUGH THE FIREWALL. SEE FIGURE 14, BELOW.
- INSTALL DRAIN HOSE TO BOTTOM OF EVAPORATOR UNIT AND ROUTE THROUGH FIREWALL. SEE FIGURE 14.

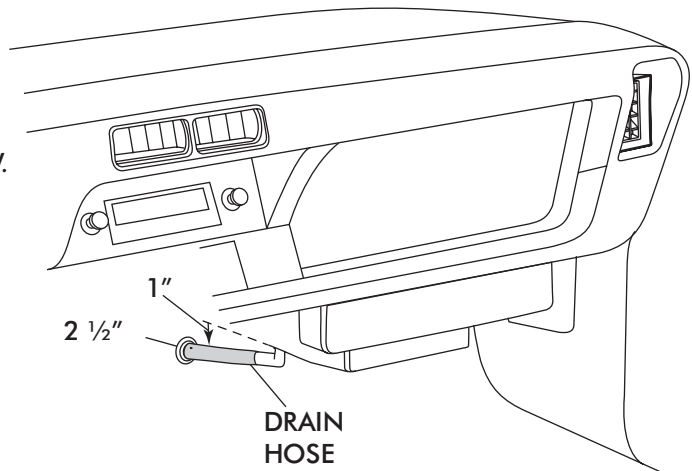
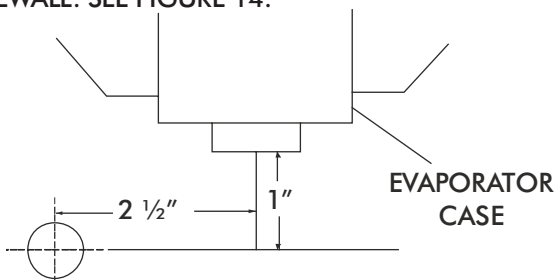

FIGURE 14

LUBRICATING O-RINGS

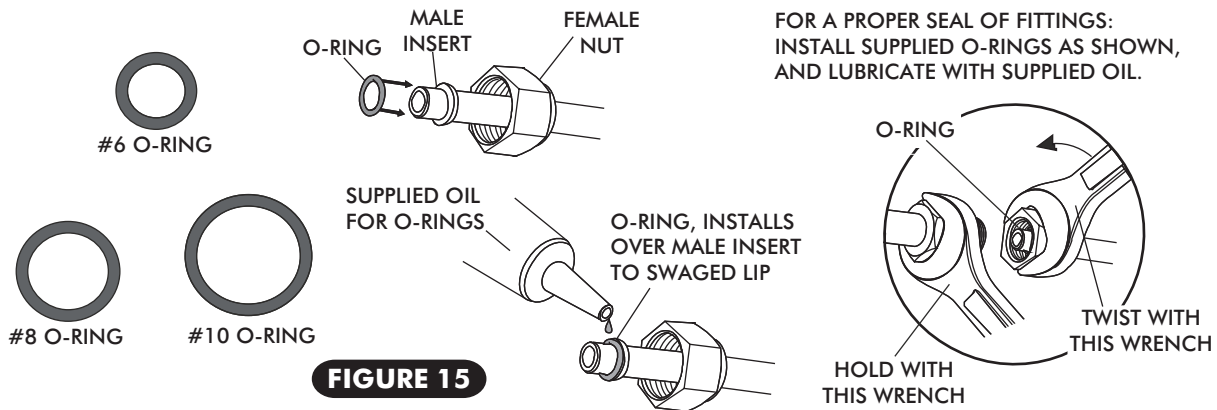

FIGURE 15

A/C HOSE INSTALLATION

STANDARD HOSE KIT

- LOCATE THE #8 COMPRESSOR A/C HOSE. LUBRICATE (2) #8 O-RINGS (SEE FIGURE 15, ABOVE) AND CONNECT THE 45° FEMALE FITTING w/ 134a SERVICE PORT TO THE #8 DISCHARGE PORT ON THE COMPRESSOR. ROUTE THE 90° FEMALE FITTING TO THE #8 CONDENSER HARDLINE COMING THROUGH CORE SUPPORT. SEE FIGURE 16, PAGE 15. TIGHTEN EACH FITTING CONNECTION AS SHOWN IN FIGURE 15 ABOVE.
- LOCATE THE #10 COMPRESSOR A/C HOSE. LUBRICATE (2) #10 O-RINGS (SEE FIGURE 15, ABOVE) AND CONNECT THE #10 135° FEMALE FITTING w/134a SERVICE PORT TO THE #10 SUCTION PORT ON THE COMPRESSOR. ROUTE THE 90° FEMALE FITTING TO THE #10 EVAPORATOR. SEE FIGURE 12 PAGE 13 AND FIGURE 16, PAGE 15. TIGHTEN EACH FITTING CONNECTION AS SHOWN IN 15 ABOVE.
- LOCATE THE #6 EVAPORATOR A/C HOSE. LUBRICATE (2) #6 O-RINGS (SEE FIGURE 15 , ABOVE) AND CONNECT THE 90° FEMALE FITTING TO THE #6 HARDLINE COMING THROUGH THE CORE SUPPORT FROM DRIER. ROUTE THE 90° FEMALE FITTING TO THE #6 EVAPORATOR. SEE FIGURE 12, PAGE 13 AND FIGURE 16 PAGE 15. TIGHTEN EACH FITTING CONNECTION AS SHOWN IN FIGURE 15, ABOVE.

MODIFIED A/C HOSE KIT

- REFER TO SEPARATE INSTRUCTIONS INCLUDED WITH MODIFIED HOSE KIT.

HEATER HOSE & HEATER CONTROL VALVE INSTALLATION

- ROUTE A PIECE OF HEATER HOSE FROM THE WATER PUMP TO THE TOP HEATER FITTING OF HEATER CORE AS SHOWN IN FIGURE 12, PAGE 13 AND FIGURE 16, BELOW. SECURE USING HOSE CLAMPS.
NOTE: OEM WATER PUMP OUTLET IS 3/4". A 3/4" x 5/8" REDUCER FITTING IS REQUIRED (NOT SUPPLIED).
- ROUTE A PIECE OF HEATER HOSE FROM THE INTAKE TO THE BOTTOM HEATER FITTING OF HEATER CORE AS SHOWN IN FIGURE 12, PAGE 13, AND FIGURE 16, BELOW. INSTALL HEATER CONTROL VALVE IN LINE WITH INTAKE MANIFOLD (PRESSURE SIDE) HEATER HOSE. SECURE USING HOSE CLAMPS AS SHOWN IN FIGURE 16, BELOW. **NOTE PROPER FLOW DIRECTION.**

A/C & HEATER HOSE ROUTING

NOTE: OEM WATER PUMP OUTLET IS 3/4". A 3/4" x 5/8" REDUCER FITTING IS REQUIRED (NOT SUPPLIED)

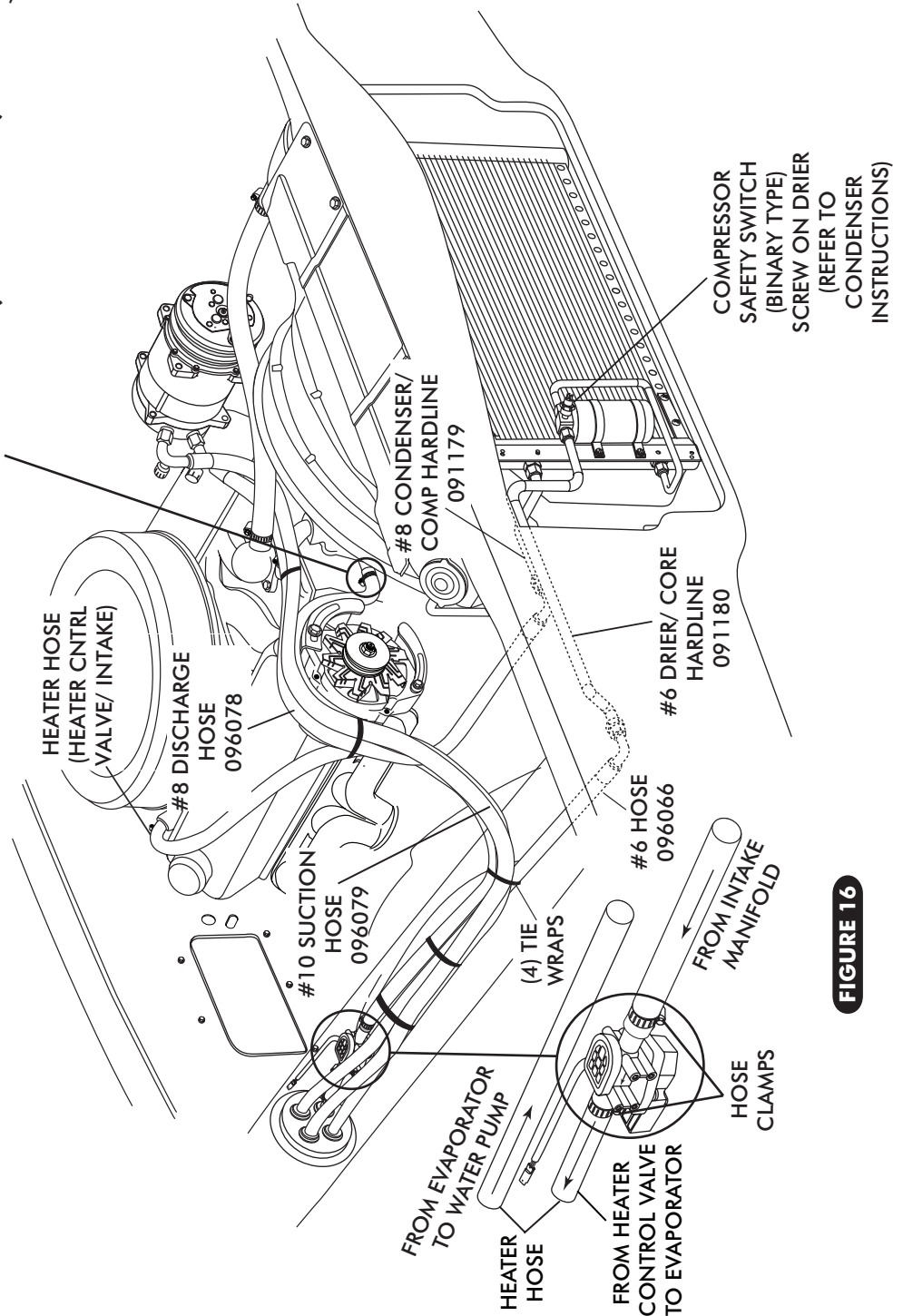

FIGURE 16



FINAL STEPS

- INSTALL DUCT HOSES AS SHOWN IN FIGURE 19 & 20, PAGE 17.
- INSTALL 3/8" GROMMET.
- ROUTE A/C WIRES THROUGH 3/8" GROMMET AS SHOWN IN FIGURE 17 (12 VOLT/ GROUND/ BINARY SWITCH/ HEATER VALVE).
- INSTALL CONTROL PANEL ASM.
- PLUG THE WIRING HARNESS IN THE ECU MODULE ON SUB CASE AS SHOWN IN FIGURE 20, PAGE 17 (WIRE ACCORDING TO WIRING DIAGRAM ON PAGE 18 AND 19).
- REINSTALL ALL PREVIOUSLY REMOVED ITEMS (BATTERY TRAY, BATTERY, INNER FENDER AND RADIATOR).
- INSTALL GLOVE BOX IN GLOVE BOX COMPARTMENT USING OEM SCREWS. SEE FIGURE 18 BELOW.
- FILL RADIATOR WITH AT LEAST A 50/50 MIXTURE OF APPROVED ANTIFREEZE AND DISTILLED WATER. IT IS THE OWNER'S RESPONSIBILITY TO KEEP THE FREEZE PROTECTION AT THE PROPER LEVEL FOR THE CLIMATE IN WHICH THE VEHICLE IS OPERATED. FAILURE TO FOLLOW ANTIFREEZE RECOMMENDATIONS WILL CAUSE HEATER CORE TO CORRODE PREMATURELY AND POSSIBLY BURST IN A/C MODE AND/OR FREEZING WEATHER, VOIDING YOUR WARRANTY.
- DOUBLE CHECK ALL FITTINGS, BRACKETS AND BELTS FOR TIGHTNESS.
- VINTAGE AIR RECOMMENDS THAT ALL A/C SYSTEMS BE SERVICED BY A CERTIFIED AUTOMOTIVE AIR CONDITIONING TECHNICIAN.
- EVACUATE THE SYSTEM FOR A MINIMUM OF 45 MINUTES PRIOR TO CHARGING AND LEAK CHECK PRIOR TO SERVICING.
- CHARGE THE SYSTEM TO THE CAPACITIES STATED ON THE INFORMATION PAGE (PAGE 4) OF THIS INSTRUCTION MANUAL.
- SEE OPERATION OF CONTROLS PROCEDURES PAGE 20.

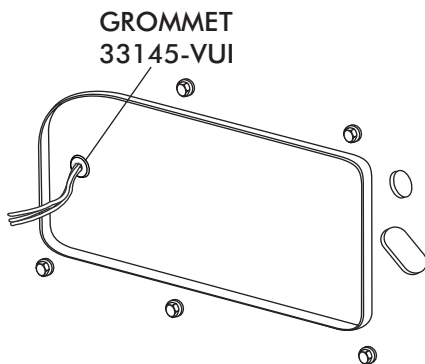

FIGURE 17

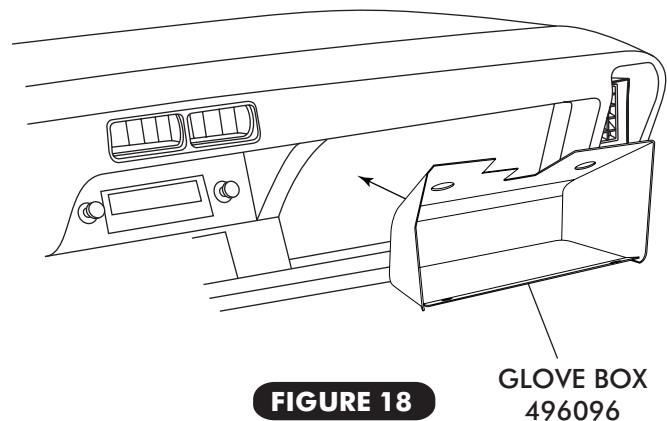

FIGURE 18

GLOVE BOX
496096



CONTROL PANEL & DUCT HOSE ROUTING

- ROUTE PASSENGER SIDE DUCT HOSE AS SHOWN BELOW.
- TIE WRAP DUCT HOSE TO DASH BRACE FOR GLOVE BOX ARM CLEARANCE.

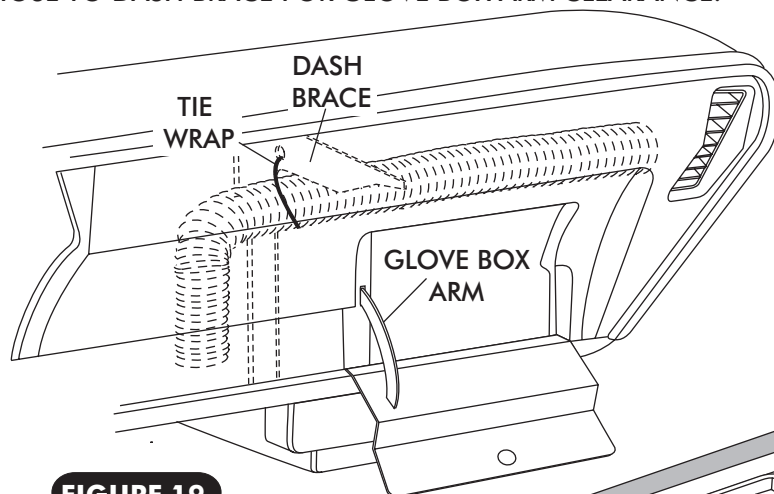

FIGURE 19

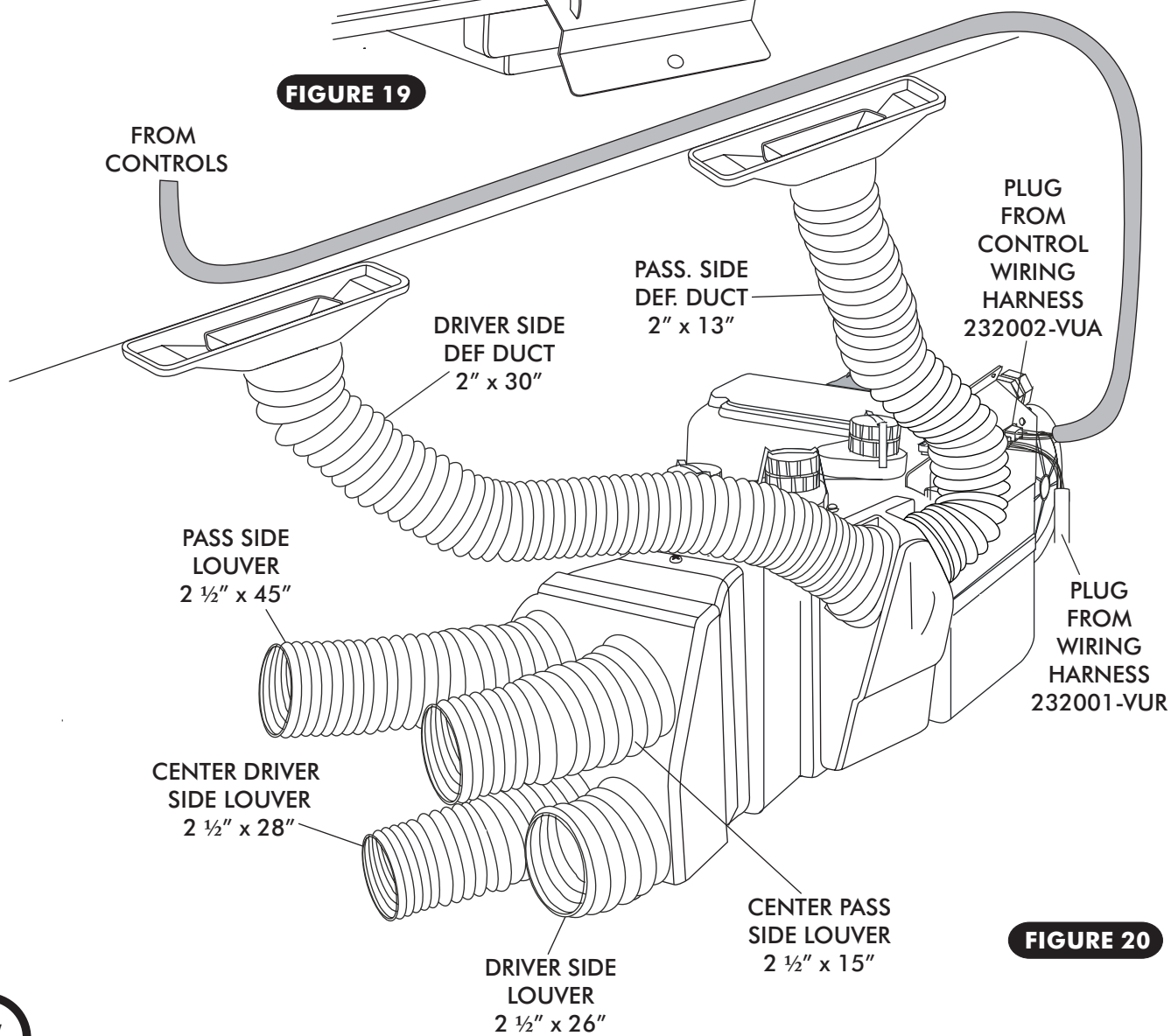
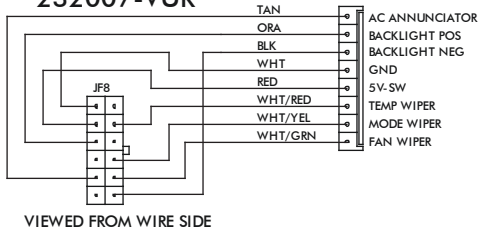

FIGURE 20



Wiring Diagram

232007-VUR



VIEWED FROM WIRE SIDE

232002-VUA

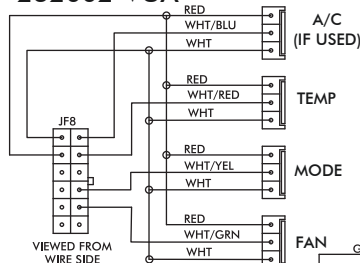

VIEWED FROM WIRE SIDE

GEN IV ECU

GEN IV WIRING DIAGRAM
REV D, 5/6/2014

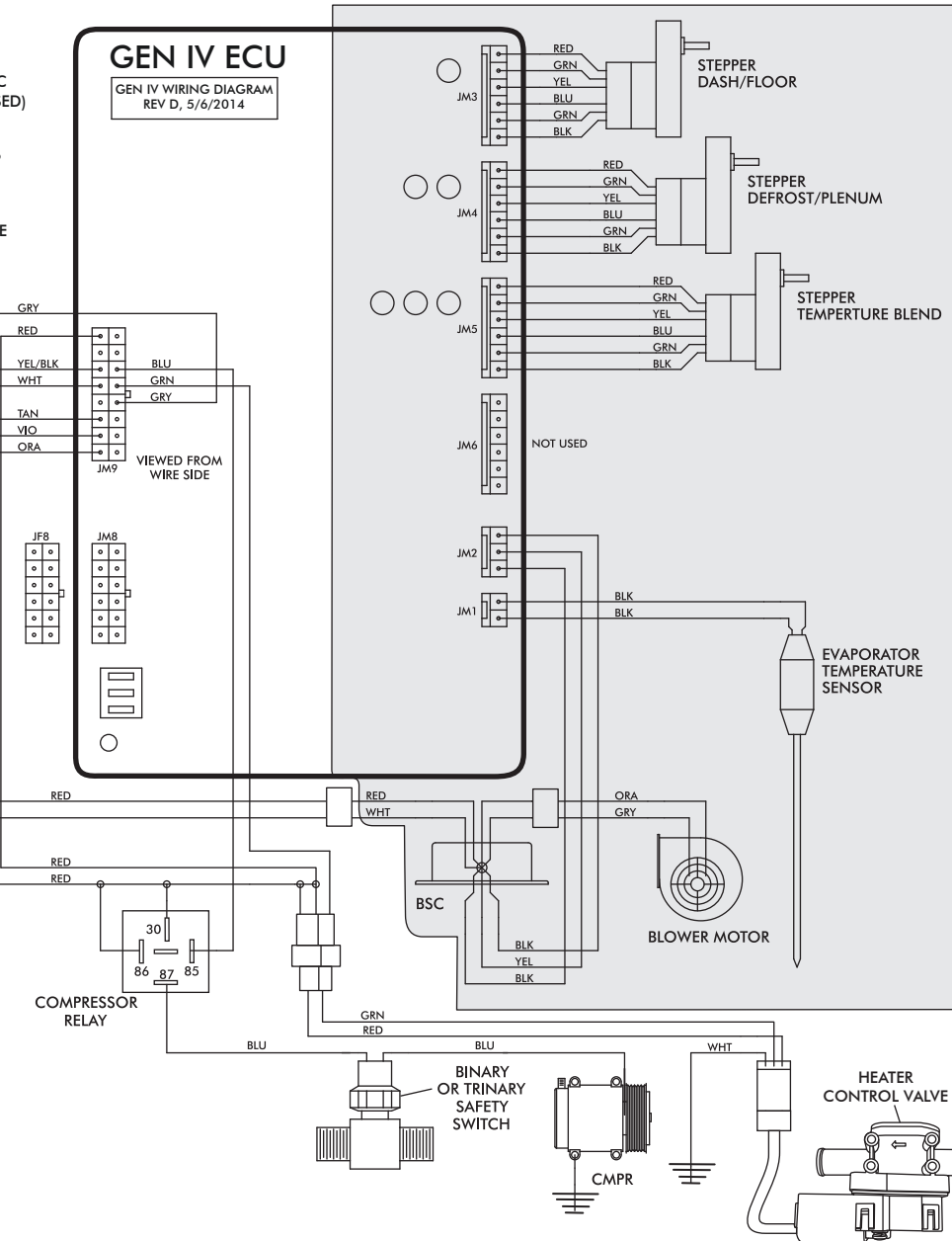

NOTE: = CHASSIS GROUND

- Dash Lamp Is Used Only With Type 232007-VUR Harness.
- Warning: Always Mount Circuit Breaker As Close to the Battery As Possible. (NOTE: Wire Between Battery and Circuit Breaker Is Unprotected and Should Be Carefully Routed to Avoid a Short Circuit).
- Wide Open Throttle Switch Contacts Close Only at Full Throttle, Which Disables A/C Compressor.



Gen IV Wiring Connection Instruction

WIRING HARNESS

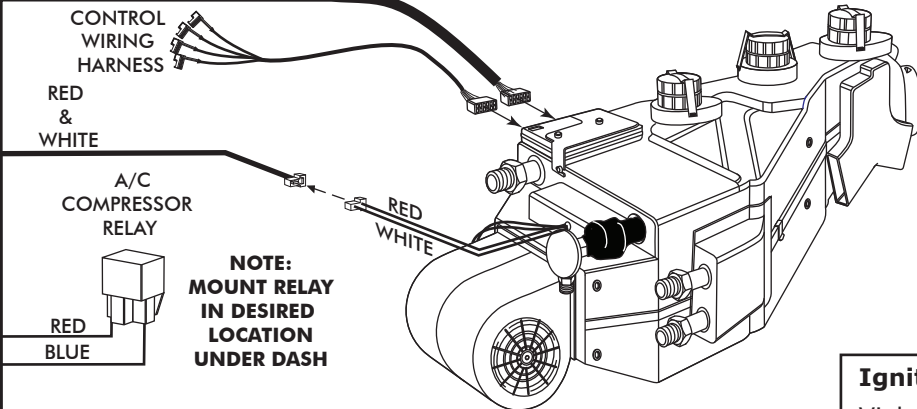

NOTE:
MOUNT RELAY
IN DESIRED
LOCATION
UNDER DASH

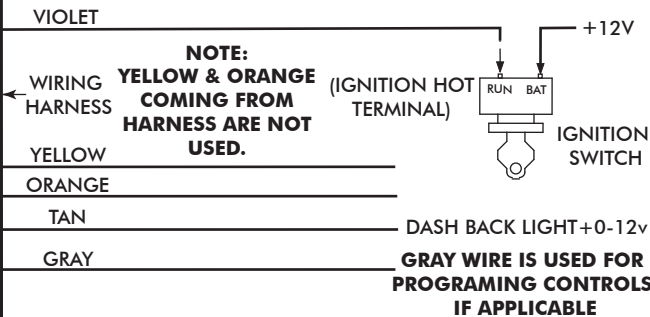

NOTE:
YELLOW & ORANGE
COMING FROM
HARNESS ARE NOT
USED.

Ignition Switch:

Violet 12V Ign Switch Source (Key On Accessory) Position Must Be Switched.

Dash Light:

Tan Wire Used Only With Vintage Air Supplied Control Panel With LED Back Light.

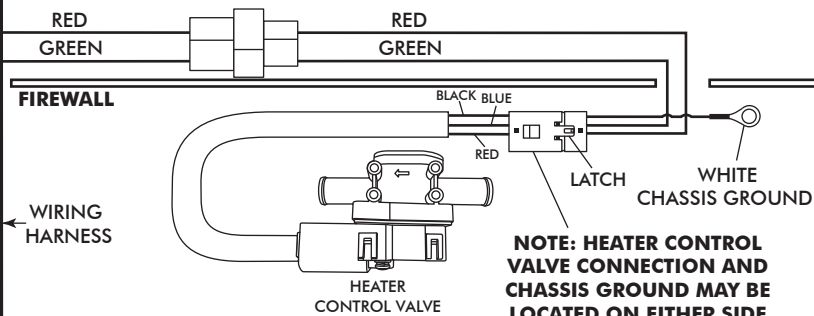

NOTE: HEATER CONTROL VALVE CONNECTION AND CHASSIS GROUND MAY BE LOCATED ON EITHER SIDE OF THE FIREWALL. ENSURE CONNECTOR IS LATCHED FIRMLY.

Heater Control Valve:

Install With Servo Motor Facing Down, As Shown. Note Flow Direction Arrow Molded Into Valve Body, And Install Accordingly.

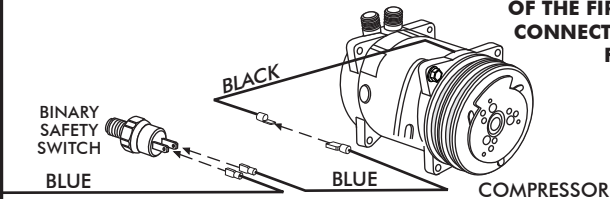

Binary/Trinary & Compressor:

Binary: Connect As Shown (Typical Compressor Wiring). Be Sure Compressor Body Is Grounded.

Trinary Switch: Connect According To Trinary Switch Wiring Diagram.

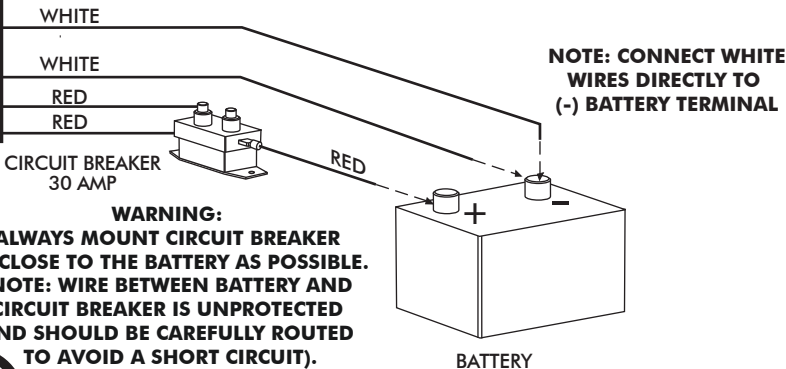

NOTE: CONNECT WHITE WIRES DIRECTLY TO (-) BATTERY TERMINAL

Circuit Breaker/Battery:

White **Must** Run To (-) Battery. Red May Run To (+) Battery Or Starter. Mount Circuit Breaker As Close to Battery As Possible.

WARNING:
ALWAYS MOUNT CIRCUIT BREAKER AS CLOSE TO THE BATTERY AS POSSIBLE. (NOTE: WIRE BETWEEN BATTERY AND CIRCUIT BREAKER IS UNPROTECTED AND SHOULD BE CAREFULLY ROUTED TO AVOID A SHORT CIRCUIT).



OPERATION OF CONTROLS

ON GEN 4 SYSTEMS WITH THREE LEVER/KNOB CONTROLS, THE TEMPERATURE CONTROL TOGGLES BETWEEN ECONOMY/HEAT AND A/C MODES. TO ACTIVATE A/C, MOVE THE TEMPERATURE LEVER ALL THE WAY TO COLD AND THEN BACK IT OFF TO THE DESIRED VENT TEMPERATURE. FOR ECONOMY/HEAT MODE, MOVE THE TEMPERATURE LEVER ALL THE WAY TO HOT AND THEN ADJUST TO THE DESIRED VENT TEMPERATURE. THE BLOWER WILL MOMENTARILY CHANGE SPEED EACH TIME YOU TOGGLE BETWEEN MODES TO INDICATE THE CHANGE.

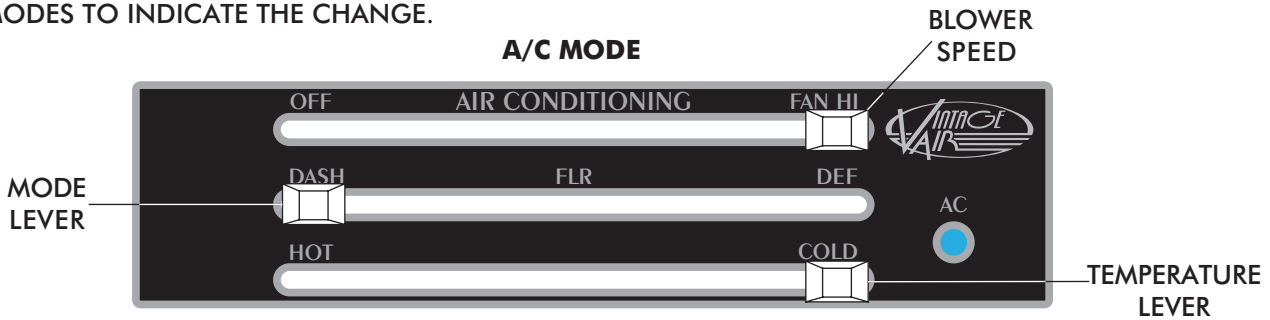

BLOWER SPEED
ADJUST TO DESIRED
SPEED

MODE LEVER
SLIDE THE LEVER ALL
THE WAY LEFT
FOR DASH MODE

TEMPERATURE LEVER
IN A/C MODE SLIDE THE
TEMPERATURE LEVER ALL THE
WAY RIGHT TO ENGAGE
COMPRESSOR. (SLIDE LEVER
LEFT OR RIGHT TO ADJUST
DESIRED TEMPERATURE)

HEAT MODE

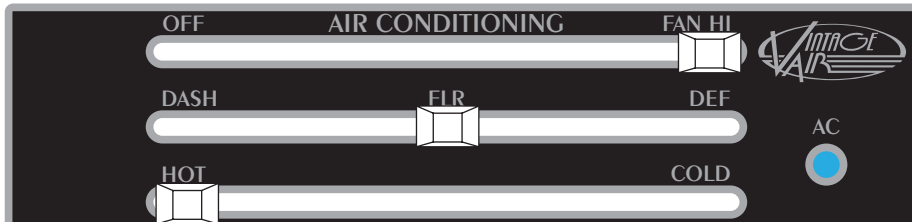

BLOWER SPEED
ADJUST TO DESIRED
SPEED

MODE LEVER
SLIDE THE LEVER TO
THE CENTER POSITION
FOR FLOOR MODE

TEMPERATURE LEVER
SLIDE THE TEMPERATURE
LEVER ALL THE WAY LEFT
TO THE HOT POSITION.
(SLIDE LEVER LEFT OR RIGHT
TO DESIRED TEMPERATURE)

DEFROST MODE

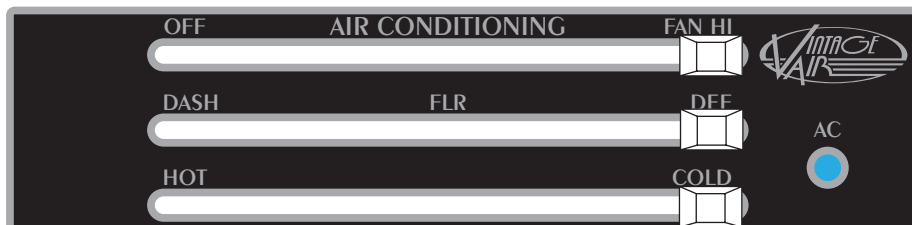

BLOWER SPEED
ADJUST TO DESIRED
SPEED

MODE LEVER
SLIDE THE LEVER ALL
THE WAY RIGHT
FOR DEF MODE

TEMPERATURE LEVER
ADJUST LEVER TO
DESIRED TEMPERATURE.
(COMPRESSOR IS
AUTOMATICALLY
ENGAGED)



Troubleshooting Guide

Symptom	Condition	Checks	Actions	Notes	
1a. Blower stays on high speed when ignition is on.	No other functions work.	Check for damaged pins or wires in control head plug.	Verify that all pins are inserted into plug. Ensure that no pins are bent or damaged in ECU.	Loss of ground on this wire renders control head inoperable.	
	All other functions work.	Check for damaged ground wire (white) in control head harness.	Verify continuity to chassis ground with white control head wire at various points.	See blower switch check procedure.	
		Check for damaged blower switch or potentiometer and associated wiring.			
1b. Blower stays on high speed when ignition is on or off.		Unplug 3-wire BSC control connector from ECU. If blower shuts off, ECU is either improperly wired or damaged.	Be sure the small, 20 GA white ground wire is connected to the battery ground post. If it is, replace the ECU.	No other part replacements should be necessary.	
		Unplug 3-wire BSC control connector from ECU. If blower stays running, BSC is either improperly wired or damaged.	Check to ensure that no BSC wiring is damaged or shorted to vehicle ground. The BSC operates the blower by ground side pulse width modulation switching. The positive wire to the blower will always be hot. If the "ground" side of the blower is shorted to chassis ground, the blower will run on HI.		
			Replace BSC (This will require removal of evaporator from vehicle).		
2. Compressor will not turn on (All other functions work).	System is not charged.	System must be charged for compressor to engage.	Charge system or bypass pressure switch.	Danger: Never bypass safety switch with engine running. Serious injury can result.	
		Check for faulty A/C potentiometer or associated wiring (Not applicable to 3-pot controls).	Check continuity to ground on white control head wire. Check for 5V on red control head wire.		To check for proper pot function, check voltage at white/blue wire. Voltage should be between 0V and 5V, and will vary with pot lever position.
		Check for disconnected or faulty thermistor.	Check 2-pin connector at ECU housing.		Disconnected or faulty thermistor will cause compressor to be disabled.
3. Compressor will not turn off (All other functions work).	System is charged.	Check for faulty A/C potentiometer or associated wiring.	Repair or replace pot/control wiring.	Red wire at A/C pot should have approximately 5V with ignition on. White wire will have continuity to chassis ground. White/Blue wire should vary between 0V and 5V when lever is moved up or down.	
		Check for faulty A/C relay.	Replace relay.		



Troubleshooting Guide (Cont.)

Symptom	Condition	Checks	Actions	Notes
4. System will not turn on, or runs intermittently.	Works when engine is not running; shuts off when engine is started (Typically early Gen IV, but possible on all versions).	Noise interference from either ignition or alternator.	Install capacitors on ignition coil and alternator. Ensure good ground at all points. Relocate coil and associated wiring away from ECU and ECU wiring. Check for burned or loose plug wires.	Ignition noise (radiated or conducted) will cause the system to shut down due to high voltage spikes. If this is suspected, check with a quality oscilloscope. Spikes greater than 16V will shut down the ECU. Install a radio capacitor at the positive post of the ignition coil (See radio capacitor installation bulletin). A faulty alternator or worn out battery can also result in this condition.
	Will not turn on under any conditions.	Verify connections on power lead, ignition lead, and both white ground wires.	Check for positive power at heater valve green wire and blower red wire. Check for ground on control head white wire.	
		Verify battery voltage is greater than 10 volts and less than 16.	Verify proper meter function by checking the condition of a known good battery.	
		Check for damaged mode switch or potentiometer and associated wiring.		
5. Loss of mode door function.	No mode change at all.	Check for obstructed or binding mode doors.		Typically caused by evaporator housing installed in a bind in the vehicle. Be sure all mounting locations line up and don't have to be forced into position.
	Partial function of mode doors.	Check for damaged stepper motor or wiring.		
		Check for at least 12V at circuit breaker.	Ensure all system grounds and power connections are clean and tight.	
6. Blower turns on and off rapidly.	Battery voltage is at least 12V.	Check for faulty battery or alternator.	Charge battery.	System shuts off blower at 10V. Poor connections or weak battery can cause shutdown at up to 11V.
	Battery voltage is less than 12V.			
7. Erratic functions of blower, mode, temp, etc.		Check for damaged switch or pot and associated wiring.	Repair or replace.	
		This is an indicator that the system has been reset. Be sure the red power wire is on the battery post, and not on a switched source. Also, if the system is pulled below 7V for even a split second, the system will reset.	Run red power wire directly to battery.	

CUT ALONG
DOTTED LINE

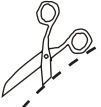

CUT ALONG
DOTTED LINE



**CUT THIS
AREA**

**KICK PANEL CUT-OUT
TEMPLATE**



EVAPORATOR KIT
561070

No.	QTY.	PART No.	DESCRIPTION
1.	1	744004-VUE	GEN IV 4 VENT EVAP SUB CASE w/ 204 ECU
2.	1	784069	1969 CUTLASS wo ACACC. KIT

CHECKED BY: _____
 PACKED BY: _____
 DATE: _____

1

**GEN IV 4 VENT
EVAP SUB CASE
w/204 ECU
744004-VUE**

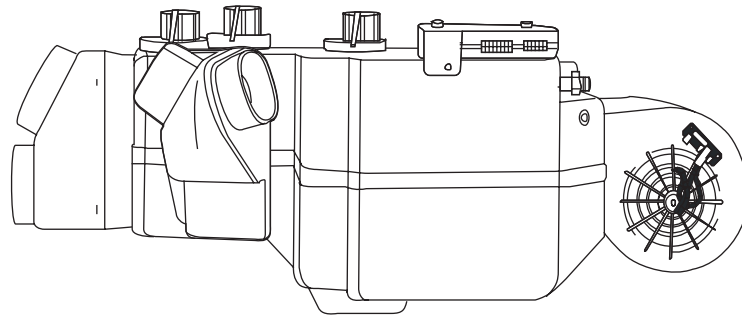

2

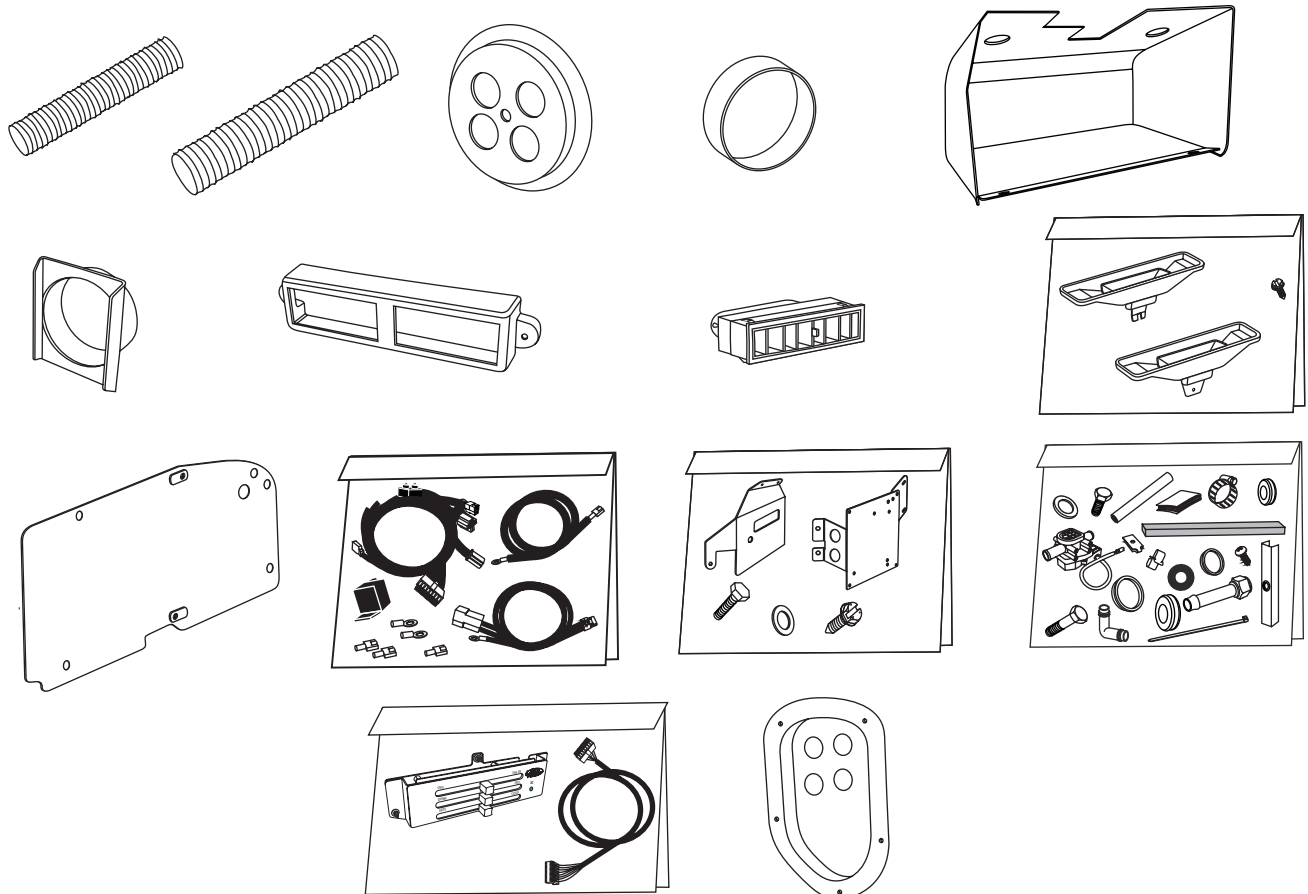

**ACCESSORY KIT
784069**

**NOTE: IMAGES MAY NOT DEPICT ACTUAL PARTS AND QUANTITIES.
REFER TO PACKING LIST FOR ACTUAL PARTS AND QUANTITIES.**