

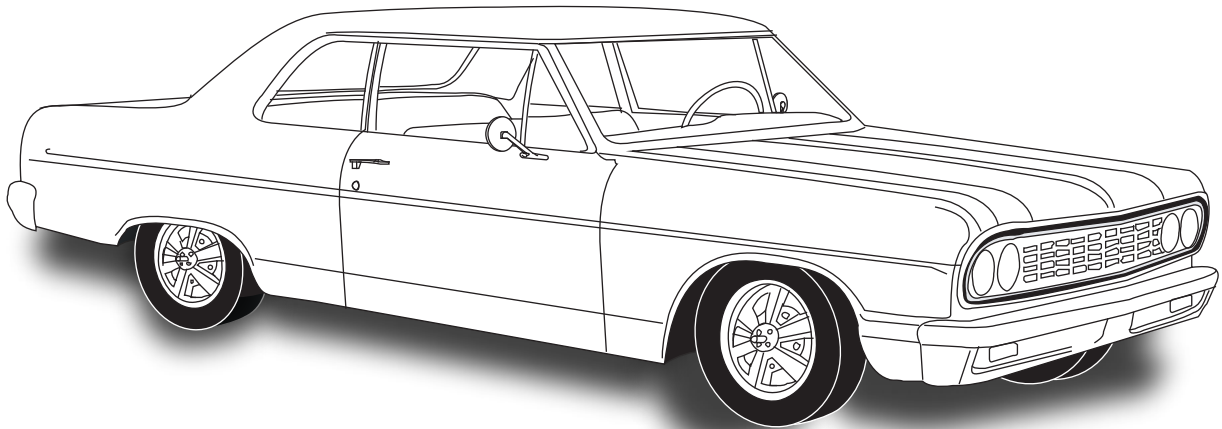

an ISO 9001:2008 Registered Company

1964-65 Chevrolet Chevelle

without Factory Air
Evaporator Kit
(561065)



18865 Goll St. San Antonio, TX 78266
Phone: 210-654-7171
Fax: 210-654-3113
www.vintageair.com



www.vintageair.com

Table of Contents

Thank you for purchasing this evaporator kit from Vintage Air. When installing these components as part of a complete SureFit™ system, Vintage Air recommends working from front to back on the vehicle, installing the condenser kit, hose kit, and compressor first, followed by the wiring, evaporator, and finally the control panel.

Cover.....	1
Table of Contents.....	2
Packing List/Parts Disclaimer.....	3
Information Page.....	4
Wiring Notice.....	5
Engine Compartment Disassembly.....	6
Condenser Assembly and Installation, Compressor and Brackets, Passenger Compartment Disassembly.....	7
Kick Panel Modification, Defrost Duct Installation.....	8
Firewall Cover Installation, Evaporator Bracket & Heater Fitting Installation.....	9
Evaporator Bracket & Heater Fitting Installation (Cont.).....	10
Fresh Air Cap Installation, Kick Panel Fresh Air Cap Installation.....	11
Evaporator Installation.....	12
Drain Hose Installation, Lubricating O-rings, A/C Hose Installation.....	13
Heater Hose & Heater Control Valve Installation, A/C and Heater Hose Routing.....	14
Final Steps.....	15
Control Panel & Duct Hose Routing.....	16
Driver Side Under Dash Louver Installation, Center/Passenger Side Under Dash Louver Installation.....	17
Wiring Diagram.....	18
Gen IV Wiring Connection Instruction.....	19
Operation of Controls.....	20
Troubleshooting Guide.....	21
Troubleshooting Guide (Cont.).....	22
Packing List.....	23



www.vintageair.com

Packing List: Evaporator Kit (561065)

No.	Qty.	Part No.	Description
1.	1	744004-VUE	Gen IV Magnum Evaporator Sub Case
2.	1	784159	Accessory Kit

**** Before beginning installation, open all packages and check contents of shipment. Please report any shortages directly to Vintage Air within 15 days. After 15 days, Vintage Air will not be responsible for missing or damaged items.**

1

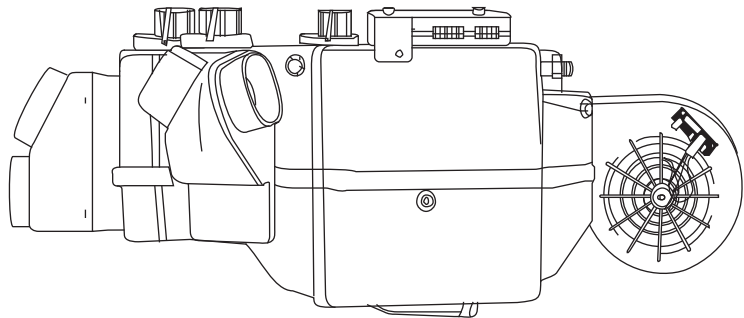

**Gen IV Magnum
Evaporator Sub Case
744004-VUE**

2

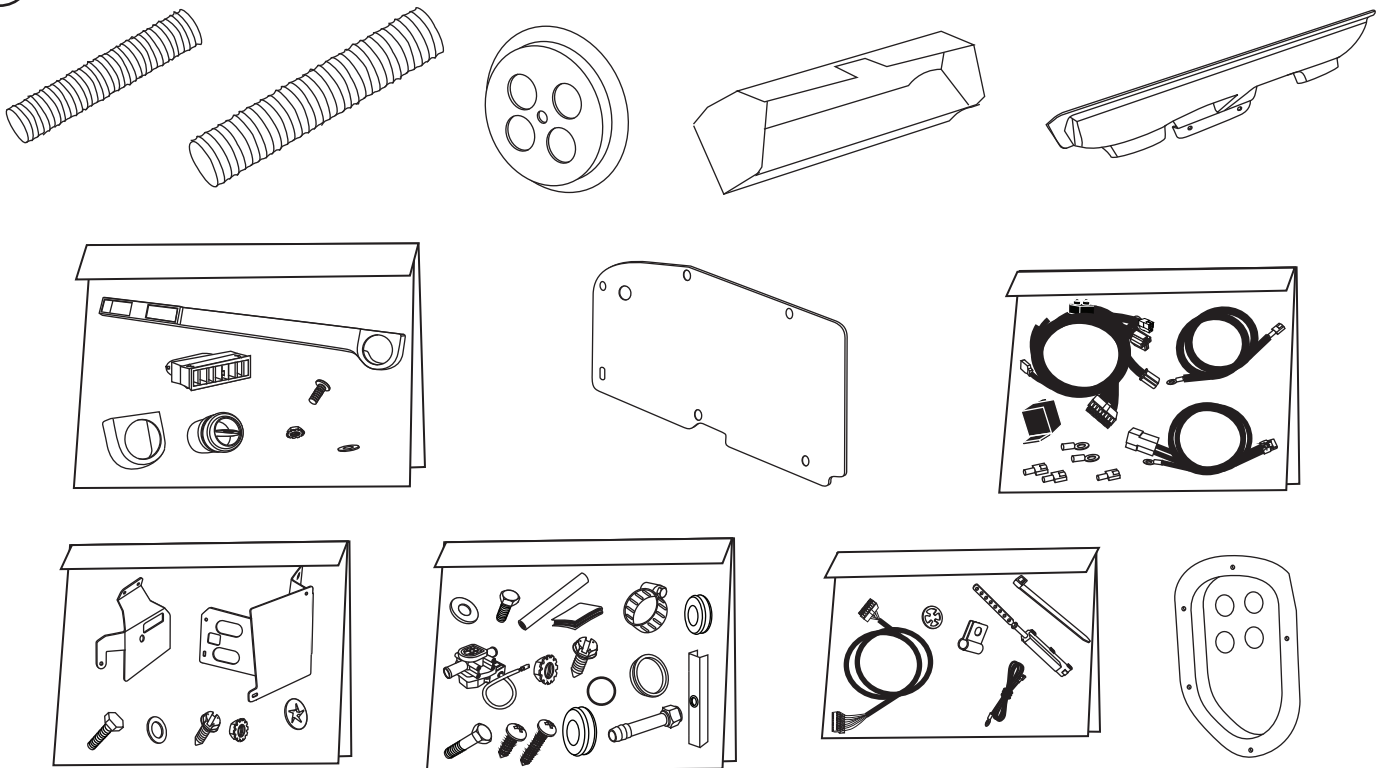

**Accessory Kit
784159**

NOTE: Images may not depict actual parts and quantities. Refer to packing list for actual parts and quantities.



www.vintageair.com

Important Notice—Please Read

For Maximum System Performance, Vintage Air Recommends the Following:

NOTE: Vintage Air systems are designed to operate with R134a refrigerant only. Use of any other refrigerant could damage your A/C system and/or vehicle, and possibly cause a fire, in addition to potentially voiding the warranties of the A/C system and its components.

Refrigerant Capacities:

Vintage Air System: 1.8 lbs. (1 lb., 12 oz.) of **R134a**, charged by weight with a quality charging station or scale. **NOTE:** Use of the proper type and amount of refrigerant is critical to system operation and performance.

Other Systems: Consult manufacturer's guidelines.

Lubricant Capacities:

New Vintage Air-supplied Sanden Compressor: No additional oil needed (Compressor is shipped with proper oil charge).

All Other Compressors: Consult manufacturer (Some compressors are shipped dry and will need oil added).

Safety Switches

Your Vintage Air system is equipped with a binary pressure safety switch. A binary switch disengages the compressor clutch in cases of extreme low pressure conditions (Refrigerant Loss) or excessively high head pressure (406 PSI) to prevent compressor damage or hose rupture. A trinary switch combines Hi/Lo pressure protection with an electric fan operation signal at 254 PSI, and should be substituted for use with electric fans. Compressor safety switches are extremely important since an A/C system relies on refrigerant to circulate lubricant.

Service Info:

Protect Your Investment: Prior to assembly, it is critical that the compressor, evaporator, A/C hoses and fittings, hardlines, condenser and receiver/drier remained capped. Removing caps prior to assembly will allow moisture, insects and debris into the components, possibly leading to reduced performance and/or premature failure of your A/C system. This is especially important with the receiver/drier.

Additionally, when caps are removed for assembly, **BE CAREFUL!** Some components are shipped under pressure with dry nitrogen.

Evacuate the System for 35-45 Minutes: Ensure that system components (Drier, compressor, evaporator and condenser) are at a temperature of at least 85° F. On a cool day, the components can be heated with a heat gun **or** by running the engine with the heater on before evacuating. Leak check and charge to specifications.

Bolts Passing Through Cowl and/or Firewall:

To ensure a watertight seal between the passenger compartment and the vehicle exterior, for all bolts passing through the cowl and/or firewall, Vintage Air recommends coating the threads with silicone prior to installation.

Heater Hose (Not Included With This Kit):

Heater hose may be purchased from Vintage Air (Part# 31800-VUD) or your local parts retailer. Routing and required length will vary based on installer preference.



www.vintageair.com

Important Wiring Notice—Please Read

Some Vehicles May Have Had Some or All of Their Radio Interference Capacitors Removed. There Should Be a Capacitor Found At Each of the Following Locations:

- 1. On the positive terminal of the ignition coil.**
- 2. If there is a generator, on the armature terminal of the generator.**
- 3. If there is a generator, on the battery terminal of the voltage regulator.**

Most alternators have a capacitor installed internally to eliminate what is called “whining” as the engine is revved. If whining is heard in the radio, or just to be extra cautious, a radio interference capacitor can be added to the battery terminal of the alternator.

It is also important that the battery lead is in good shape and that the ground leads are not compromised. There should be a heavy ground from the battery to the engine block, and additional grounds to the body and chassis.

If these precautions are not observed, it is possible for voltage spikes to be present on the battery leads. These spikes come from ignition systems, charging systems, and from switching some of the vehicle’s other systems on and off. Modern computer-operated equipment can be sensitive to voltage spikes on the power leads, which can cause unexpected resets, strange behavior, and/or permanent damage.

Vintage Air strives to harden our products against these types of electrical noise, but there is a point where a vehicle’s electrical system can be degraded so much that nothing can help.

Radio interference capacitors should be available at most auto and truck parts suppliers. They typically are cylindrical in shape, a little over an inch long, a little over a half inch in diameter, and they have a single lead coming from one end of the cylinder with a terminal on the end of the wire, as well as a mounting clip which is screwed into a good ground on the vehicle. The specific value of the capacitance is not too significant in comparison to ignition capacitors that are matched with the coil to reduce pitting of the points.

- Care must be taken, when installing the compressor lead, not to short it to ground. The compressor lead must not be connected to a condenser fan or to any other auxiliary device. Shorting to ground or connecting to a condenser fan or any other auxiliary device may damage wiring, the compressor relay, and/or cause a malfunction.
- When installing ground leads on Gen IV systems, the blower control ground and ECU ground must be connected directly to the negative battery post.
- For proper system operation, the heater control valve must be connected to the ECU.



www.vintageair.com

Engine Compartment Disassembly

NOTE: Before starting the installation, check the function of the vehicle (horn, lights, etc.) for proper operation, and study the instructions, illustrations, & diagrams.

Perform the Following:

1. Disconnect the battery.
2. Remove the battery and the battery tray (retain).
3. Drain and remove the radiator (retain).
4. Remove the OEM blower assembly (discard). **NOTE: To remove the blower assembly (under hood) and the air distribution system (under dash), the factory manual recommends removing the passenger side inner fender.**
5. Remove the OEM heater hoses (discard) (See Figure 1, below).
6. Remove the OEM heater wiring (discard) (See Figure 1, below).

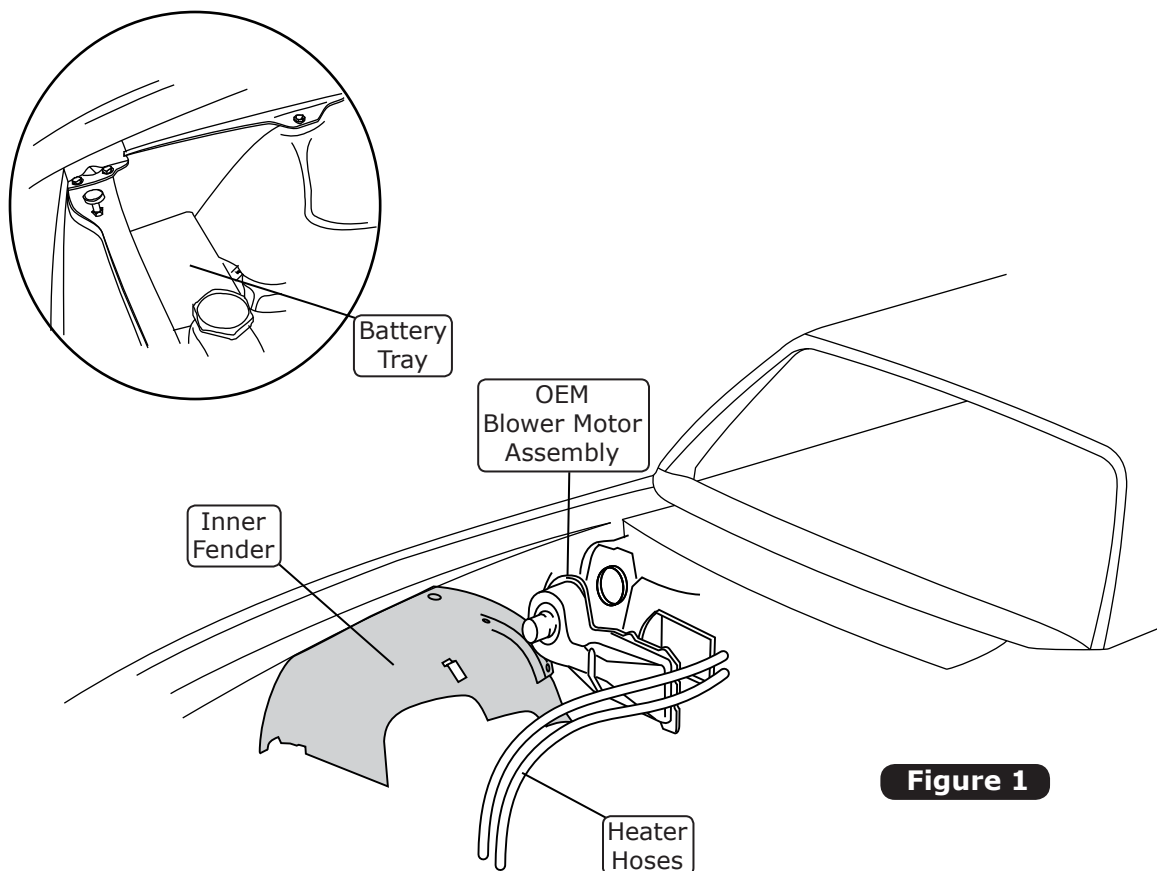

Figure 1



www.vintageair.com

Condenser Assembly and Installation

1. Refer to separate instructions included with the condenser kit to install the condenser.
2. Binary switch installation (Refer to condenser instructions).

Compressor and Brackets

1. Refer to separate instructions included with the bracket kit to install the compressor bracket.

Passenger Compartment Disassembly

Perform the Following:

1. Remove glove box door (retain).
2. Remove glove box (discard).
3. Disconnect all wires and cables from control panel and radio.
4. Remove control panel and radio.
5. Remove OEM heater assembly.
6. Using a chisel or die grinder, remove (3) spot welds on the defrost duct (See Figure 2, below).
7. Remove OEM defrost duct assembly (See Figure 3, below).

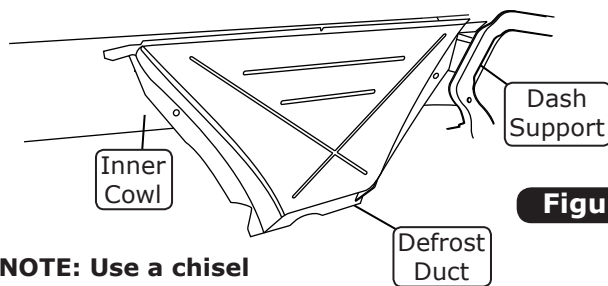

Figure 2

NOTE: Use a chisel or die grinder to break spot welds.

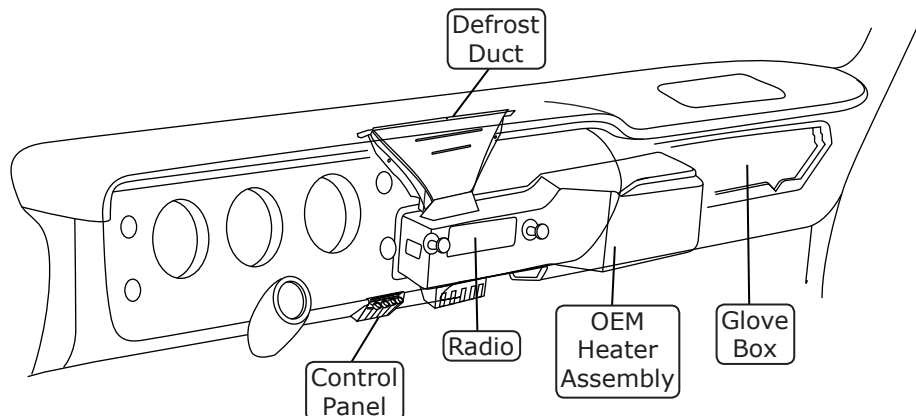

Figure 3



www.vintageair.com

Kick Panel Modification

1. Remove the kick panel.
2. Remove the kick panel fresh air door assembly by removing (5) OEM screws.
3. Disconnect the pull cable assembly from under the dash (discard) (See Figure 4, below).
4. Modify the passenger side kick panel as shown in Figure 4a, below.

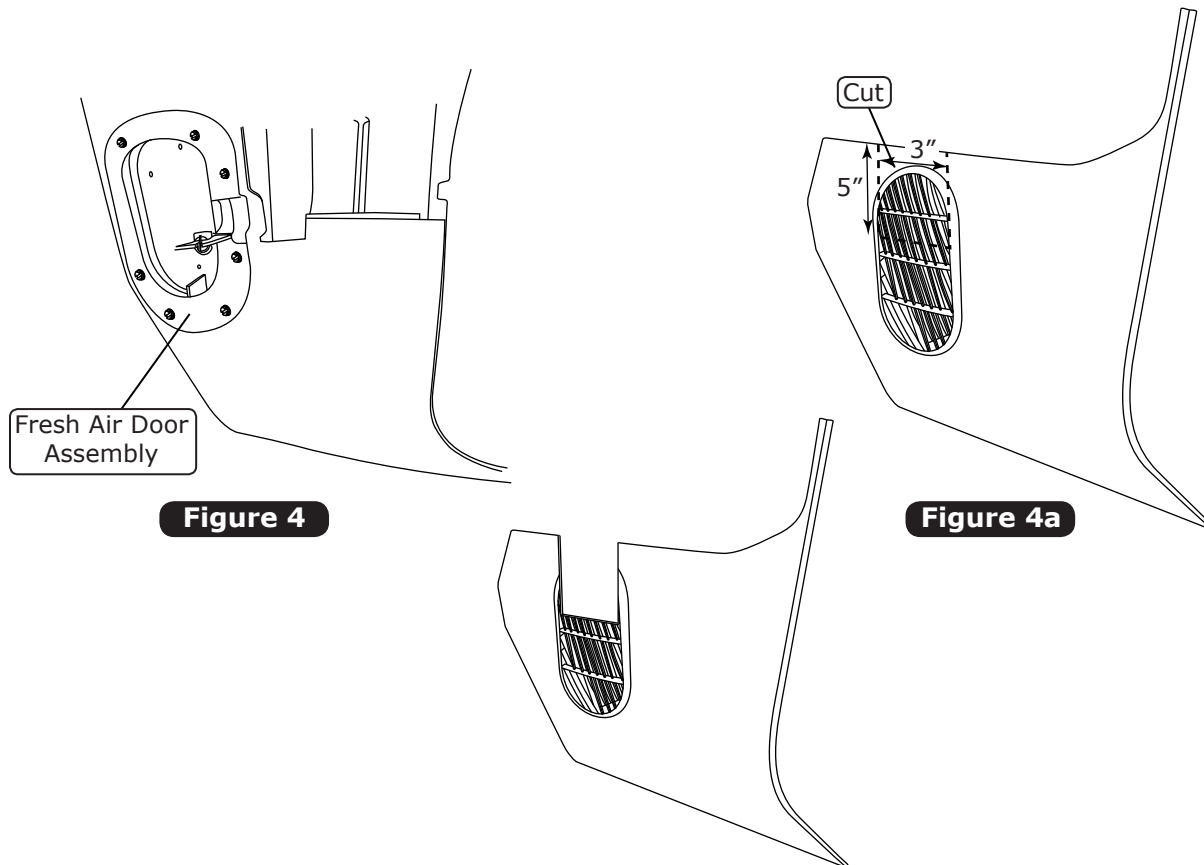

Defrost Duct Installation

1. Install the defrost duct under the dash, and align it with the OEM opening. Attach the defrost duct to the cowl using (2) #10 x 1/2" sheet metal screws (See Figure 5, below). **NOTE: Apply silicone to the screws to ensure a leak-free installation.**

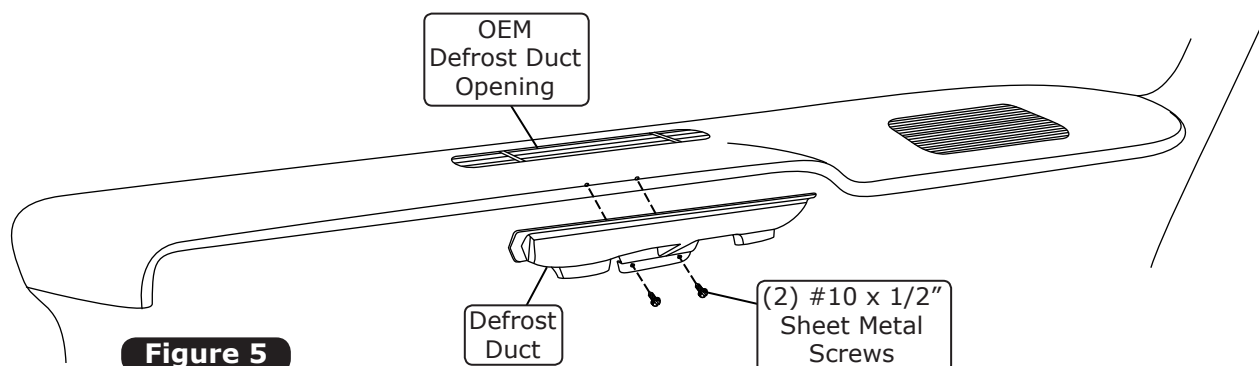



www.vintageair.com

Firewall Cover Installation

NOTE: To ensure a watertight seal between the passenger compartment and the vehicle exterior, for all bolts passing through the firewall, Vintage Air recommends coating the threads with silicone prior to installation.

1. Apply a 1/4" bead of silicone around the mating surface of the firewall cover as shown in Figure 6, below.
2. From the passenger compartment, install the firewall cover onto the firewall. Secure the firewall cover to the firewall using (3) 1/4-20 x 1" hex bolts, (3) 1/4" flat washers and (3) 1/4-20 nuts with star washers as shown in Figure 6, below.

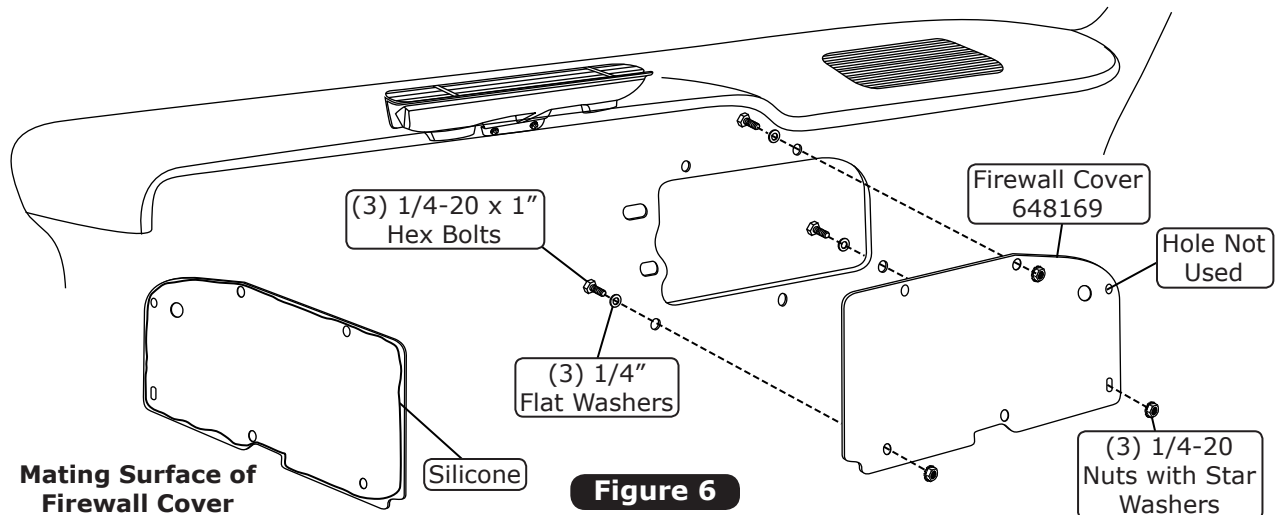

Evaporator Bracket & Heater Fitting Installation

1. On a workbench, install (2) heater fittings with properly lubricated O-rings (See Figure 14, Page 13, and Figure 8, Page 10).
2. Install (2) 1/4-20 x 1" hex bolts and (2) 1/4" push nut bolt retainers onto the evaporator rear mounting bracket as shown in Figure 8, Page 10.
3. Install the evaporator front and rear mounting brackets onto the evaporator using (6) 1/4-20 x 1/2" hex bolts, (supplied on the evaporator sub case) and tighten as shown in Figure 7, below, and Figure 8, Page 10.
4. Place the evaporator sub case on the passenger side floorboard. Using properly lubricated O-rings, install the A/C hoses onto the evaporator (See Figure 14, Page 13, and Figure 11, Page 12). **NOTE: Wrap the #10 fitting connections with press tape (See Figure 11, Page 12).**
5. Install the heater hoses, securing them with hose clamps (See Figure 11, Page 12).

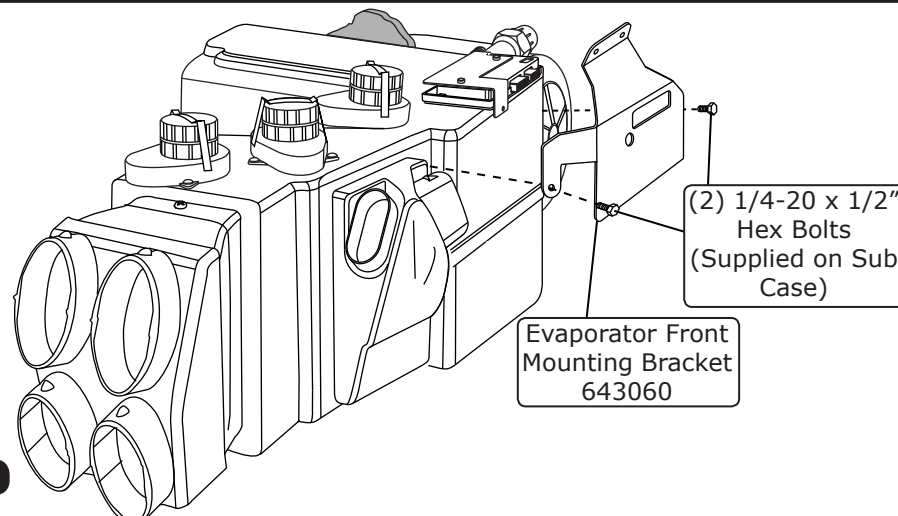



www.vintageair.com

Evaporator Bracket & Heater Fitting Installation (Cont.)

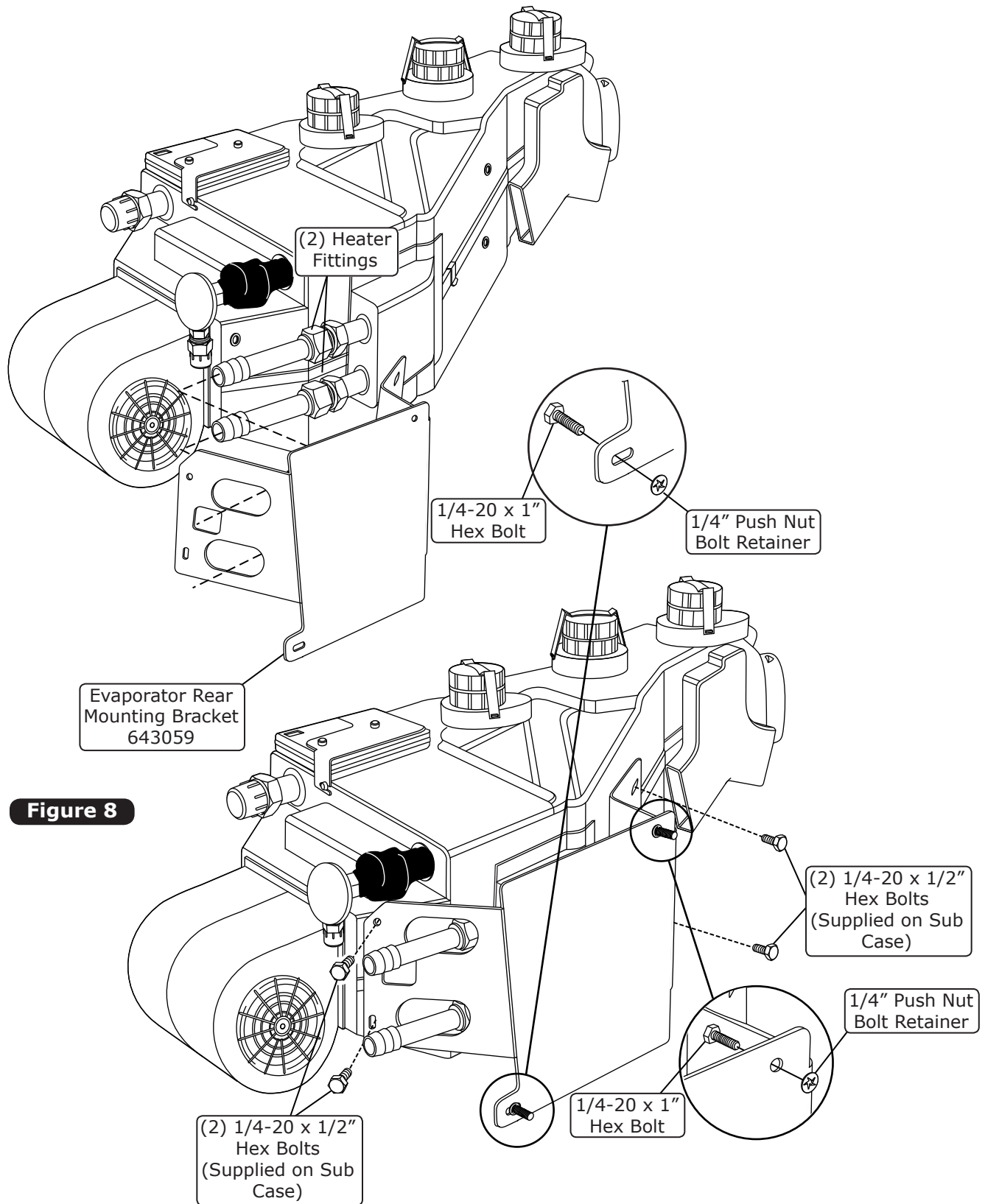



www.vintageair.com

Fresh Air Cap Installation

NOTE: To ensure a watertight seal between the passenger compartment and the vehicle exterior, for all bolts passing through the firewall, Vintage Air recommends coating the threads with silicone prior to installation.

1. Install (4) grommets into the fresh air cap (See Figure 9, below).
2. Apply a 1/4" bead of silicone around the mating surface of the fresh air cap as shown in Figure 9, below.
3. Attach the fresh air cap to the firewall using the fresh air cap bracket, a 1/4-20 x 1 1/2" bolt, and a washer as shown in Figure 9, below. **NOTE: The fresh air cap installs on the engine side of the firewall.**

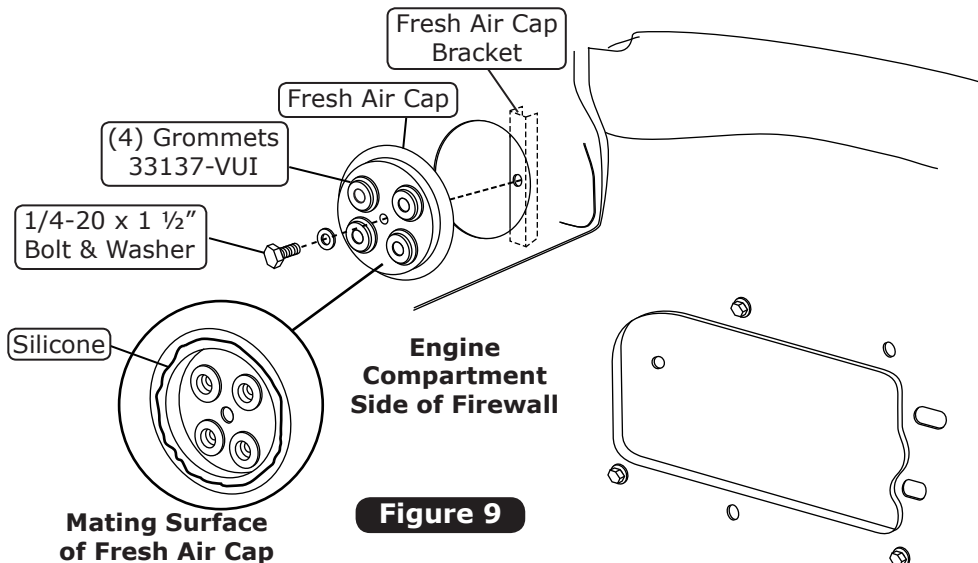

Kick Panel Fresh Air Cap Installation

1. Install (4) grommets into the kick panel fresh air cap (See Figure 10a, below).
2. Route the A/C and heater hoses through the fresh air cap and kick panel fresh air cap as shown in Figures 10 and 10b, below.
3. Apply a 1/4" bead of silicone around the mating surface of the kick panel fresh air cap as shown in Figure 10a, below.
4. Secure the kick panel fresh air cap using OEM screws as shown in Figure 10b, below.

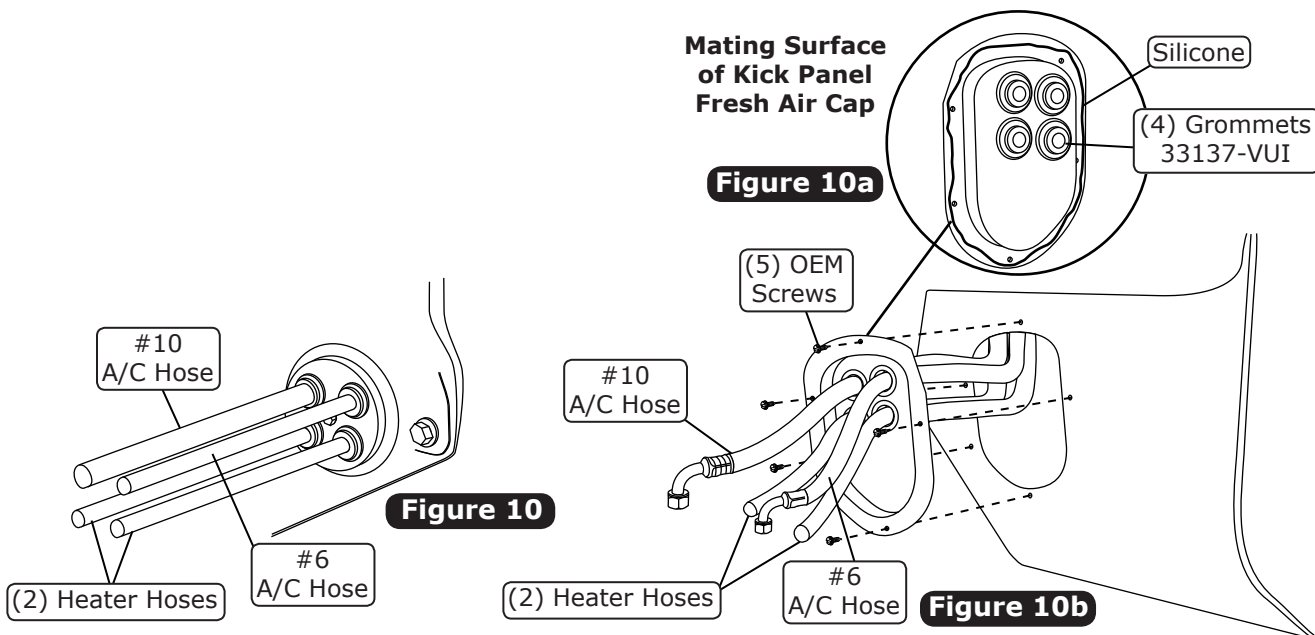



www.vintageair.com

Evaporator Installation

NOTE: To ensure a watertight seal between the passenger compartment and the vehicle exterior, for all bolts passing through the firewall, Vintage Air recommends coating the threads with silicone prior to installation.

1. Lift the evaporator unit up under the dashboard. Secure loosely to the firewall using (2) 1/4-20 nuts and (2) flat washers (See Figure 12, below). **NOTE: To ensure proper drainage, it is very important that the evaporator is level, both left-right and fore-aft. Check for level on the flat portions of the case around the drain.**
2. Using (2) #14 x 3/4" sheet metal screws, secure the front evaporator mounting bracket to the cowl (See Figure 12, below).
3. Verify that the evaporator unit is level and square to the dash. Then, tighten all mounting bolts. **NOTE: Tighten the bolt on the firewall first. Then tighten the front mounting bracket.**

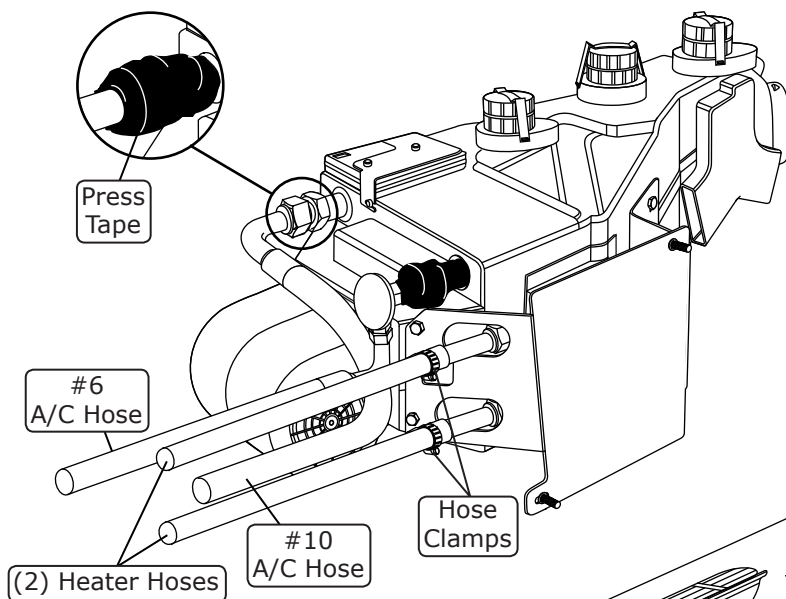

Figure 11

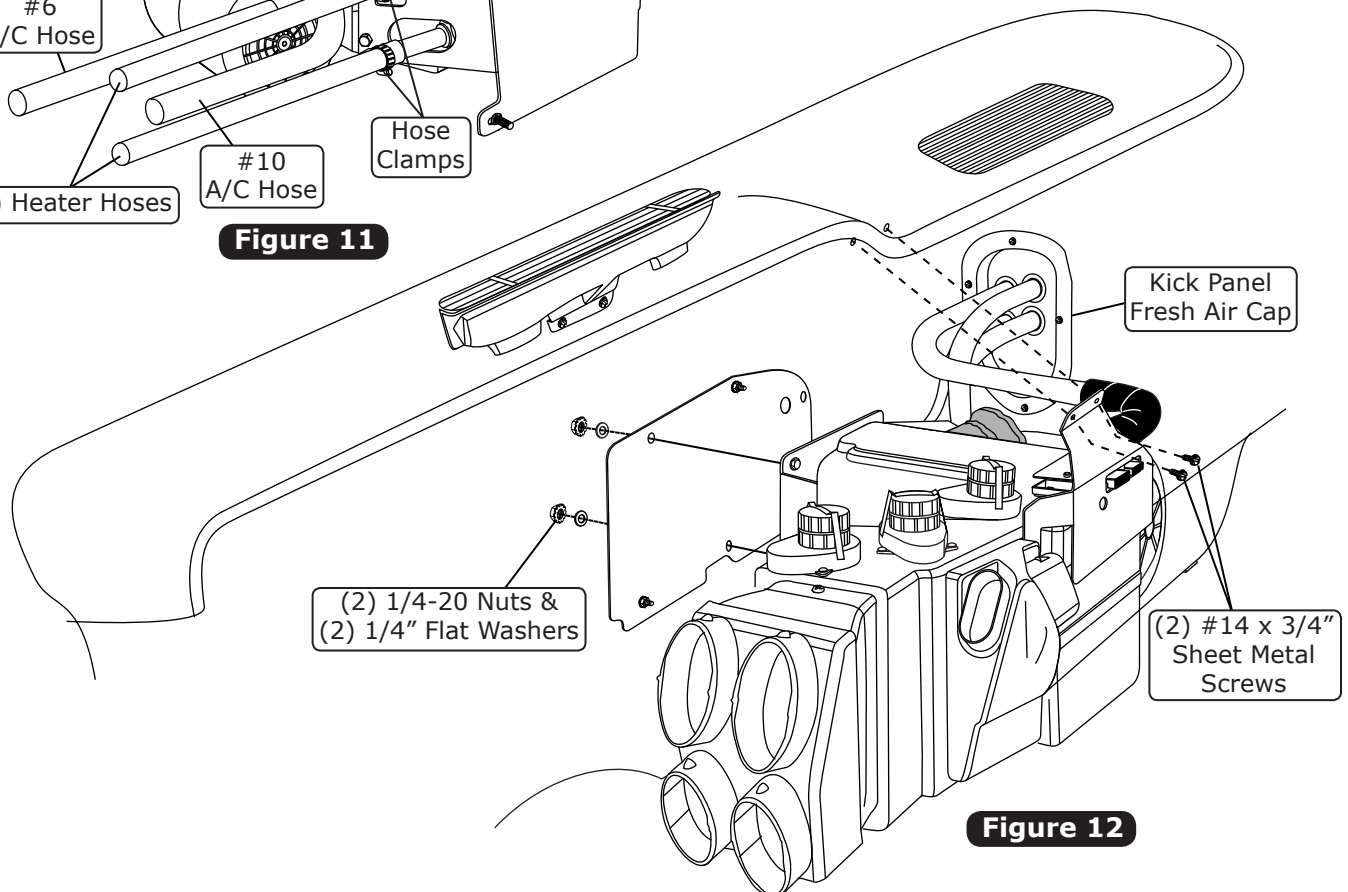

Figure 12



www.vintageair.com

Drain Hose Installation

1. Locate the evaporator drain on the bottom of the evaporator case.
2. In line with the drain, lightly make a mark on the firewall. Measure 1" down, and drill a 5/8" hole through the firewall (See Figure 13, below).
3. Attach the drain hose to the outlet on the bottom of the evaporator unit, and route it through the firewall.
4. Install a 1/2" 90° drain elbow onto the drain hose (See Figure 13, below).

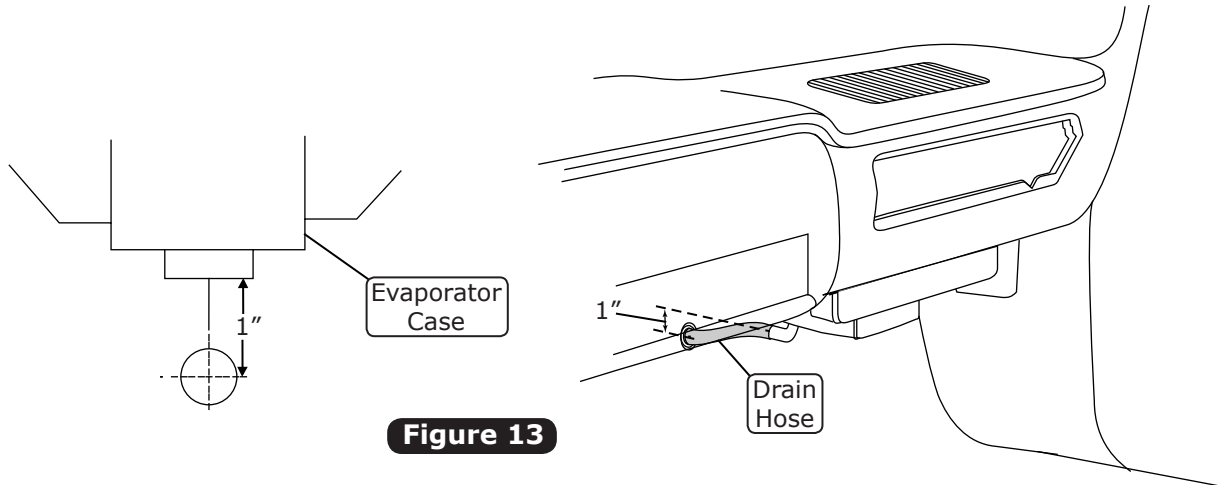
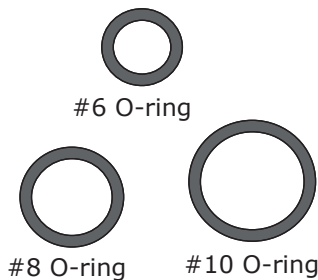
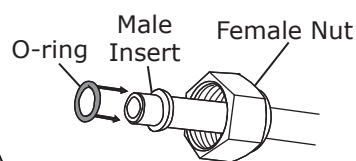

Figure 13

Lubricating O-rings



NOTE: Standard torque specifications:
#6: 11 to 13 ft-lb.
#8: 15 to 20 ft-lb.
#10: 21 to 27 ft-lb.



For a proper seal of fittings: Install supplied O-rings as shown, and lubricate with supplied oil.

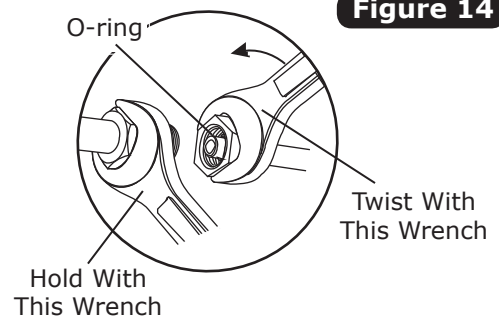
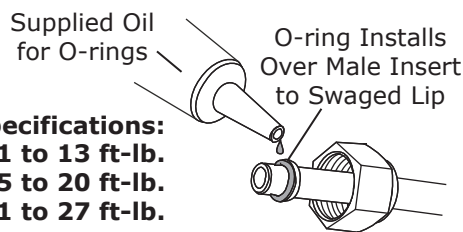

Figure 14

A/C Hose Installation

Standard Hose Kit:

1. Locate the #8 compressor A/C hose. Lubricate (2) #8 O-rings (See Figure 14, above) and connect the 90° fitting to the #8 discharge port on the compressor. Then route the 45° fitting with 134a service port to the #8 condenser hardline coming through the core support (See Figure 15, Page 14). Tighten each fitting connection as shown in Figure 14, above.
2. Locate the #10 compressor A/C hose. Lubricate (2) #10 O-rings (See Figure 14, above) and connect the 45° fitting with 134a service port to the #10 suction port on the compressor. Then route the 90° fitting to the #10 fitting on the evaporator (See Figure 11, Page 12, and Figure 15, Page 14). Tighten each fitting connection as shown in Figure 14, above.
3. Locate the #6 evaporator A/C hose. Lubricate (2) #6 O-rings (See Figure 14, above) and connect the 90° fitting to the drier. Then route the 90° fitting to the #6 fitting on the evaporator (See Figure 11, Page 12, and Figure 15, Page 14). Tighten each fitting connection as shown in Figure 14, above.

Modified Hose Kit:

1. Refer to separate instructions included with modified hose kit.



www.vintageair.com

Heater Hose & Heater Control Valve Installation

1. Route a piece of heater hose from the water pump to the left heater core fitting as shown in Figure 10, Page 11, and Figure 15, below. Secure using hose clamps.
2. Route a piece of heater hose from the intake to the heater control valve, and from the heater control valve to the right heater core fitting as shown in Figure 10, Page 11, and Figure 15, below. **NOTE: Install the heater control valve in line with the intake manifold (pressure side) heater hose, and secure using hose clamps. Also note proper flow direction.**

A/C and Heater Hose Routing

NOTE: Vintage Air Systems use 5/8" heater connections. On engines equipped with 3/4" hose nipples, these will need to be removed and replaced with 5/8" nipples (not supplied). For water pumps with a cast-in 3/4" heater outlet, a 3/4" x 5/8" reducer fitting (not supplied) will need to be installed in the heater hose.

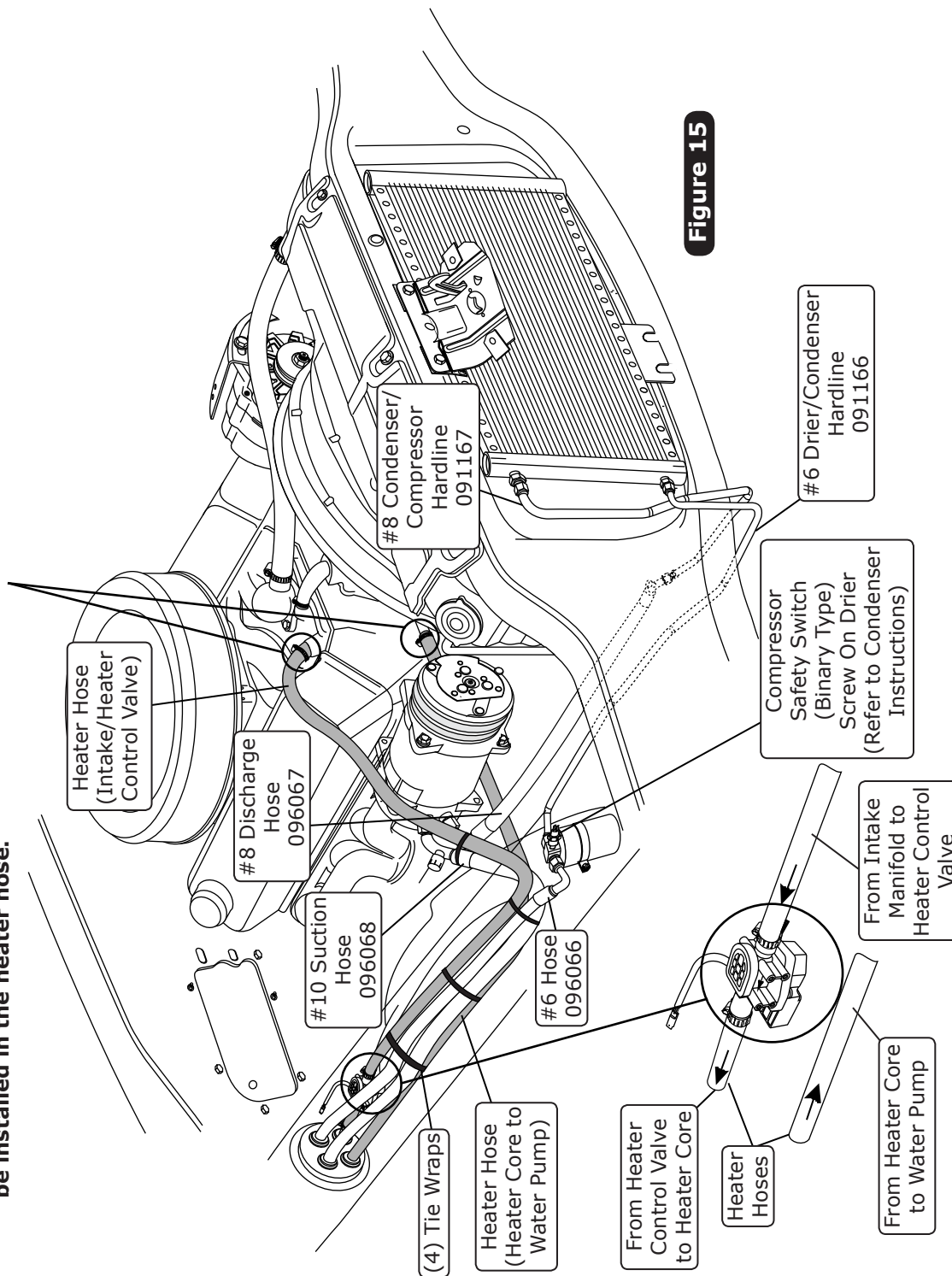

Figure 15

NOTE: Flow Direction Follows Molded Arrow on Valve.



www.vintageair.com

Final Steps

1. Install the duct hoses as shown in Figure 18, Page 16.
2. Route the A/C wires (12 volt/ground/binary switch/heater control valve) through the 3/8" grommet as shown in Figure 16, below.
3. Install the control panel assembly. Refer to the control panel instructions.
4. Plug the wiring harnesses into the ECU module on the sub case as shown in Figure 18, Page 16. Wire according to the wiring diagrams on Pages 18 and 19.
5. Install the glove box using (4) #8 x 1/2" pan head screws (See Figure 17, below).
6. Reinstall kick panel.
7. Install louvers as shown on Page 17.
8. Reinstall all previously removed items.
9. Fill radiator with at least a 50/50 mixture of approved antifreeze and distilled water. It is the owner's responsibility to keep the freeze protection at the proper level for the climate in which the vehicle is operated. Failure to follow antifreeze recommendations will cause heater core to corrode prematurely and possibly burst in A/C mode and/or freezing weather, voiding your warranty.
10. Double check all fittings, brackets and belts for tightness.
11. Vintage Air recommends that all A/C systems be serviced by a licensed automotive A/C technician.
12. Evacuate the system for a minimum of 45 minutes prior to charging, and perform a leak check prior to servicing.
13. Charge the system to the capacities stated on Page 4 of this instruction manual.
14. See Operation of Controls procedures on Page 20.

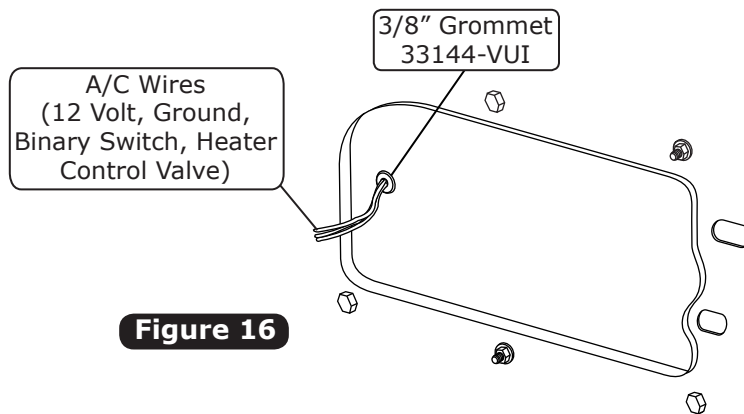

Figure 16

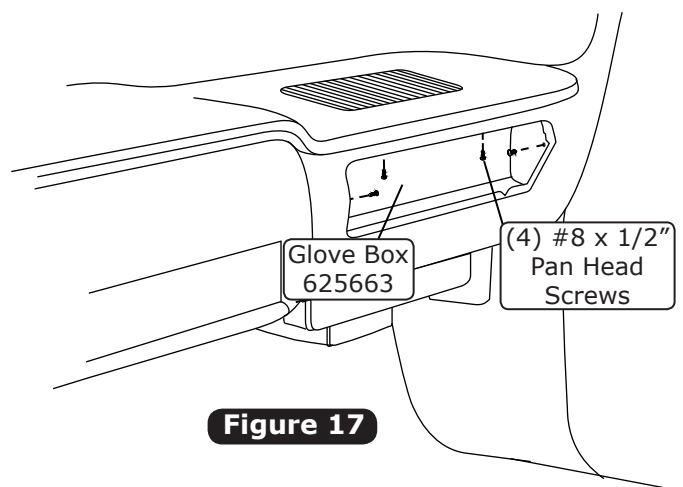

Figure 17



www.vintageair.com

Control Panel & Duct Hose Routing

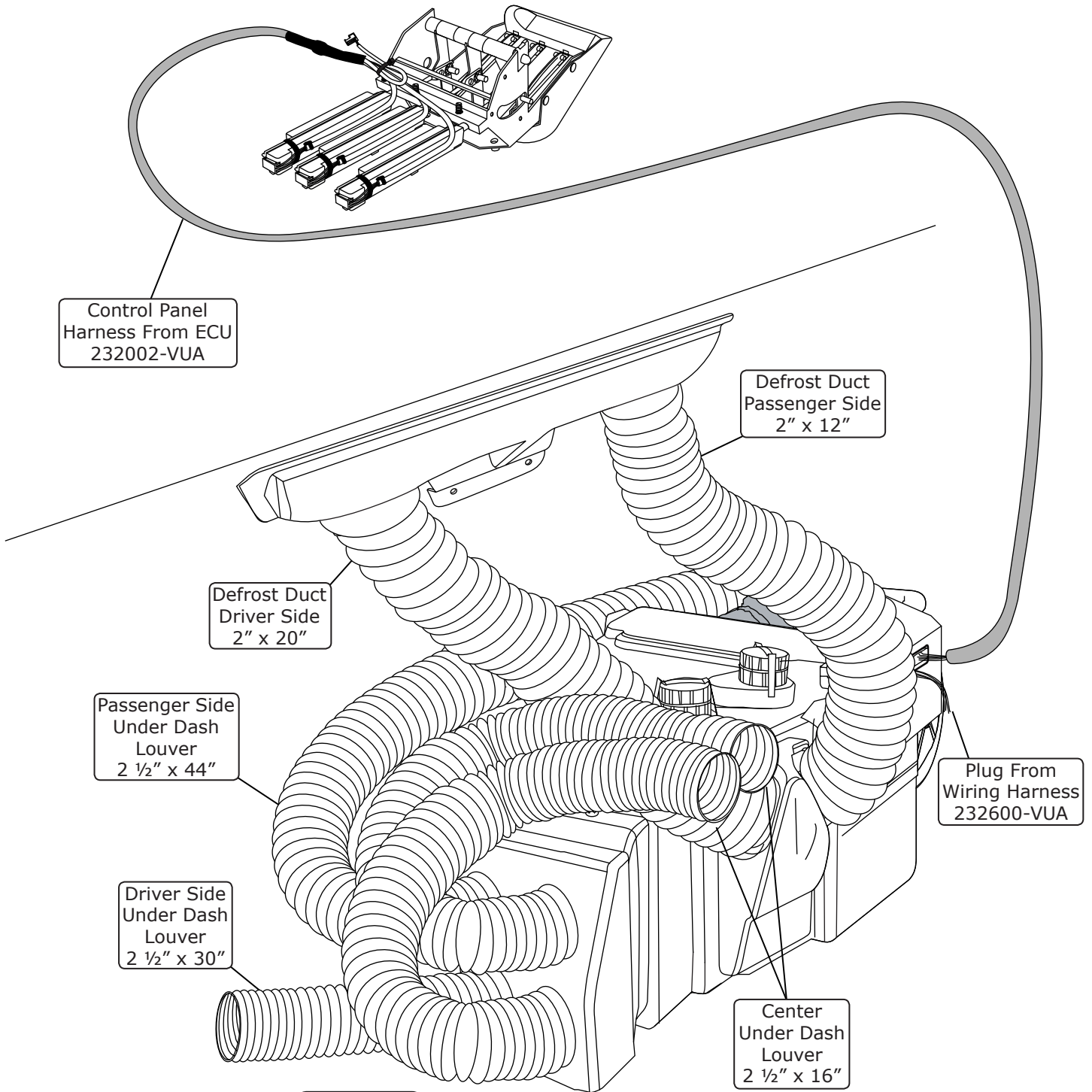

Figure 18



www.vintageair.com

Driver Side Under Dash Louver Installation

1. Place the louver housing under the dash, and align it with the OEM holes.
2. Secure the louver housing under the dash using (2) 10-32 x 3/4" pan head screws, (4) 3/16" flat washers and (2) 10-32 nuts with star washers as shown in Figure 19, below.
3. Install the louver into the louver housing as shown in Figure 19a, below.

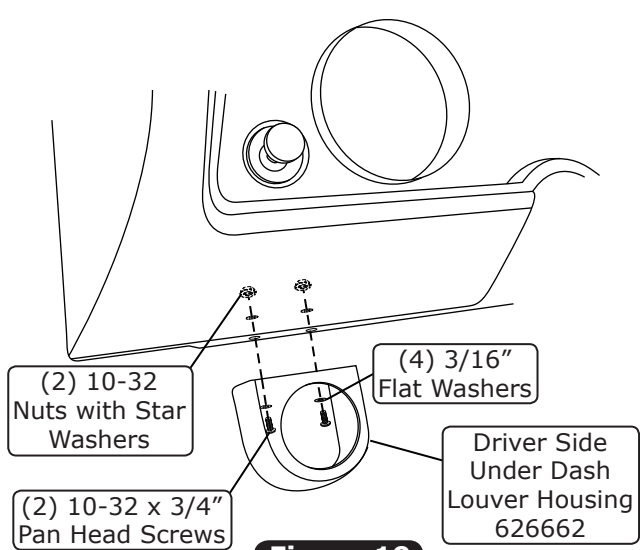

Figure 19

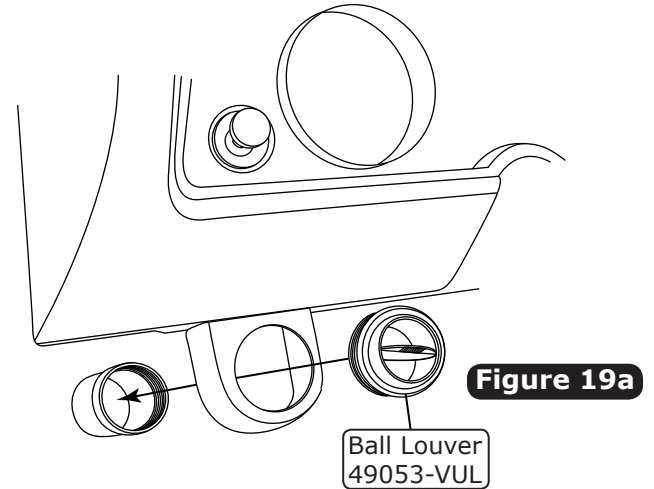

Figure 19a

Center/Passenger Side Under Dash Louver Installation

1. Place the passenger side louver bezel under the dash, and align it with the OEM holes.
2. Secure the louver bezel under the dash using (3) 10-32 x 3/4" pan head screws, (6) 3/16" flat washers and (3) 10-32 nuts with star washers as shown in Figure 20, below.
3. Install the louvers into the louver bezel as shown in Figure 20a, below.

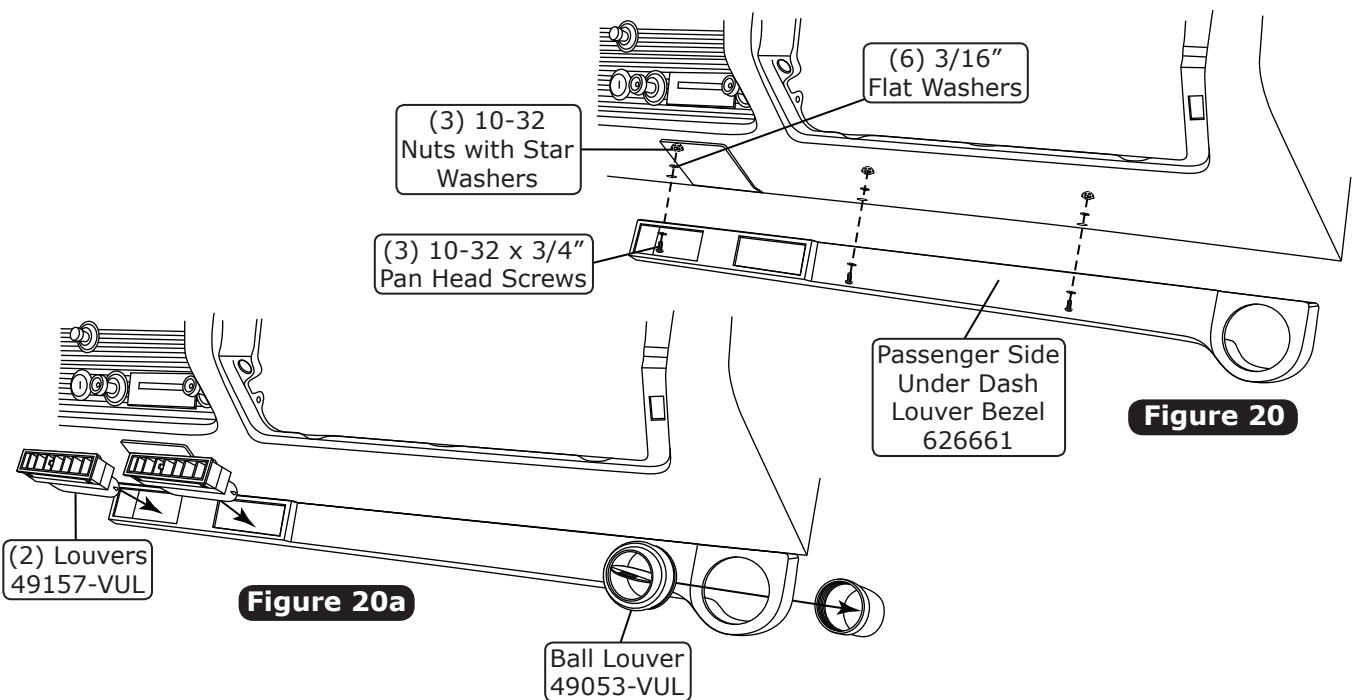

Figure 20

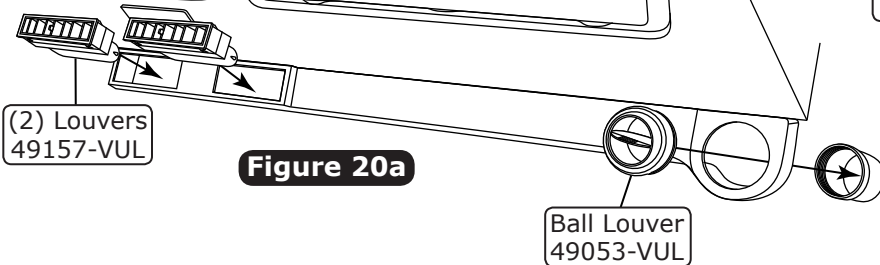

Figure 20a



www.vintageair.com

Wiring Diagram

232007-VUR

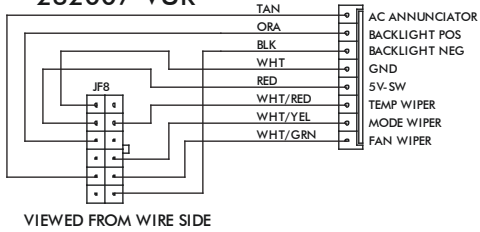

VIEWED FROM WIRE SIDE

232002-VUA

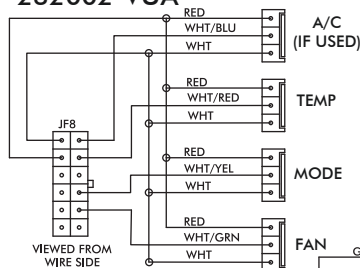

VIEWED FROM WIRE SIDE

GEN IV ECU

GEN IV WIRING DIAGRAM
REV D, 5/6/2014

PRE-WIRED

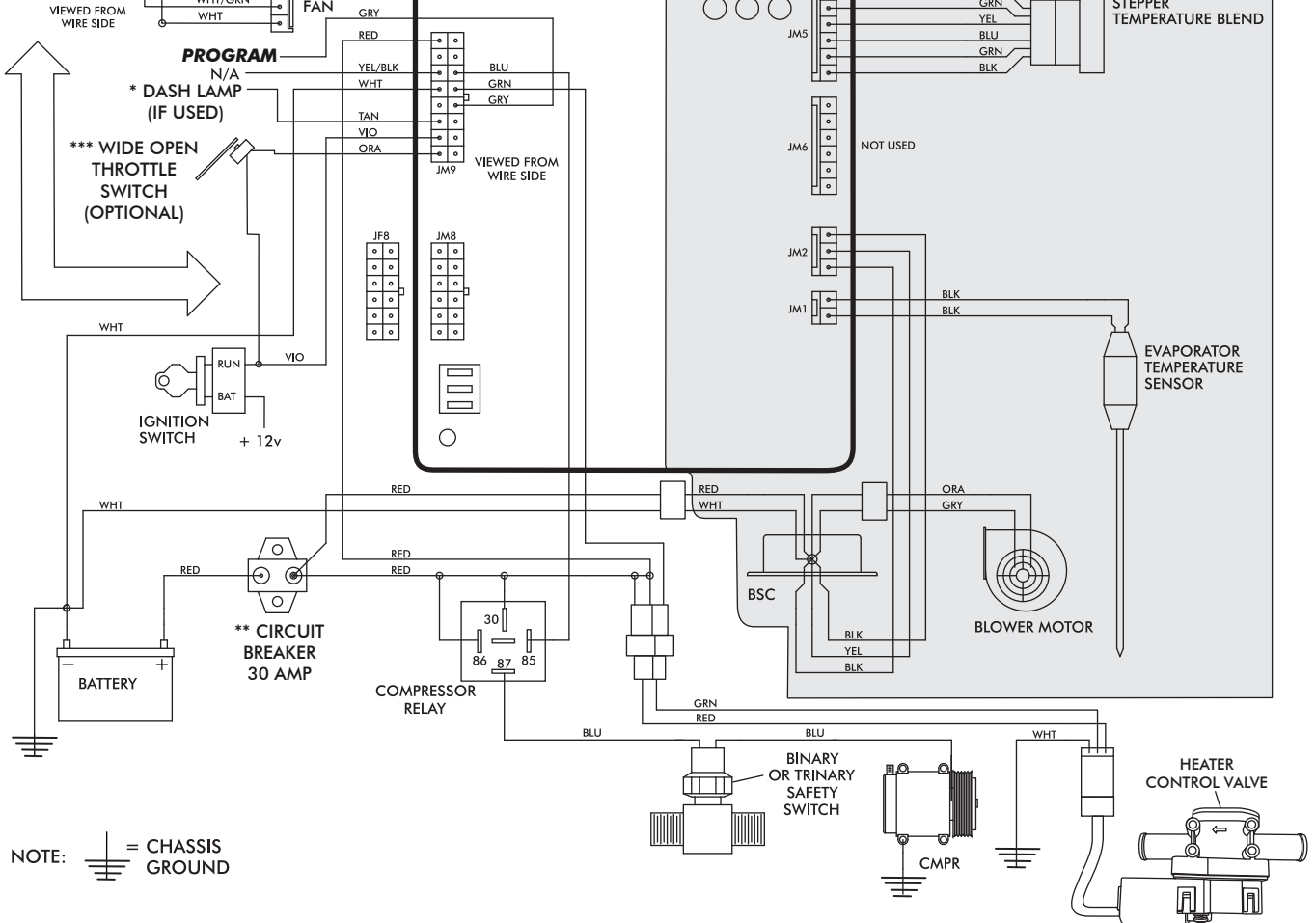

NOTE: = CHASSIS GROUND

- Dash Lamp Is Used Only With Type 232007-VUR Harness.
- **Warning:** Always Mount Circuit Breaker As Close to the Battery As Possible. (NOTE: Wire Between Battery and Circuit Breaker Is Unprotected and Should Be Carefully Routed to Avoid a Short Circuit).
- Wide Open Throttle Switch Contacts Close Only at Full Throttle, Which Disables A/C Compressor.



www.vintageair.com

Gen IV Wiring Connection Instruction

WIRING HARNESS

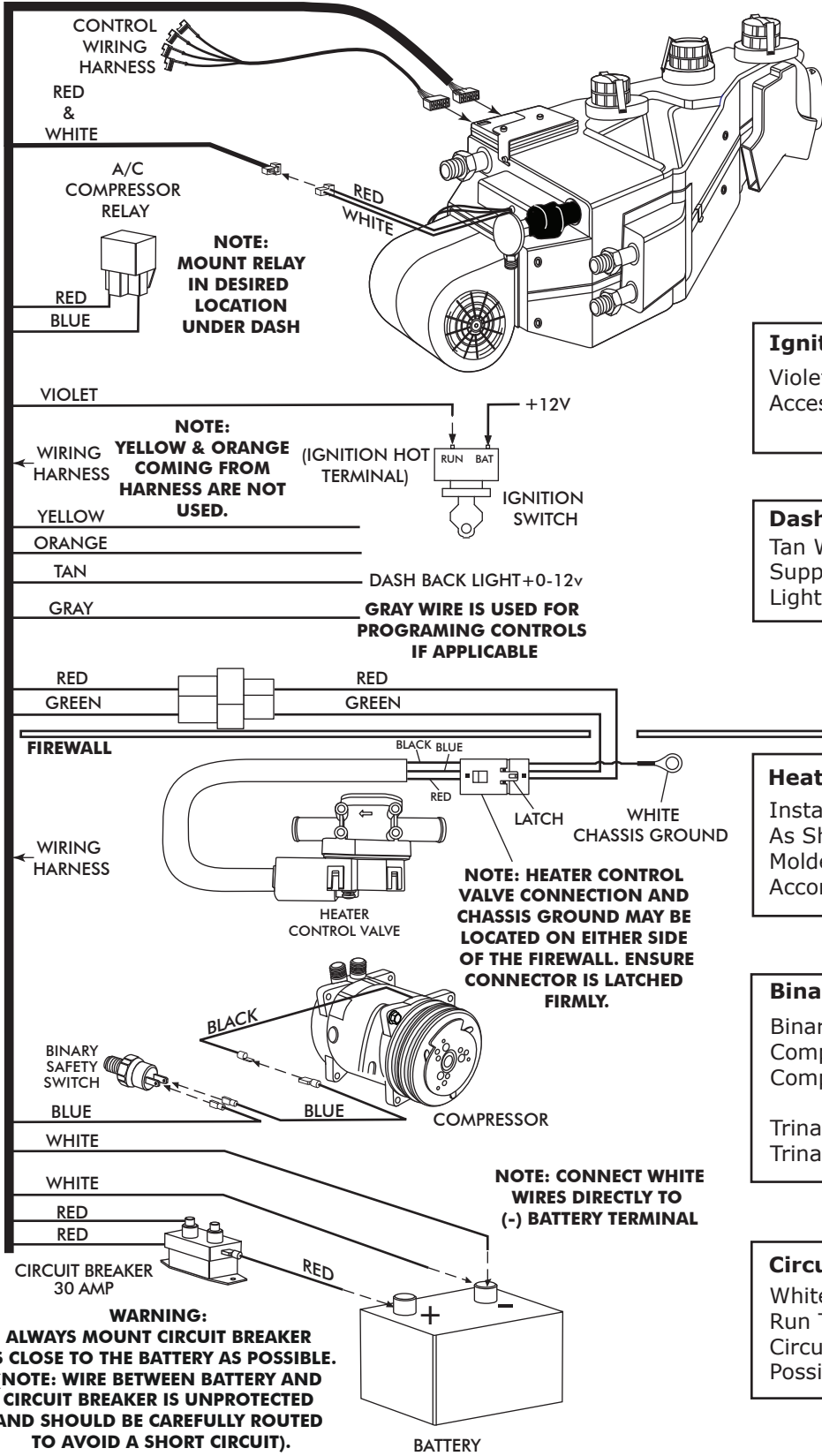

Ignition Switch:
Violet 12V Ign Switch Source (Key On Accessory) Position Must Be Switched.

Dash Light:
Tan Wire Used Only With Vintage Air Supplied Control Panel With LED Back Light.

Heater Control Valve:
Install With Servo Motor Facing Down, As Shown. Note Flow Direction Arrow Molded Into Valve Body, And Install Accordingly.

Binary/Trinary & Compressor:
Binary: Connect As Shown (Typical Compressor Wiring). Be Sure Compressor Body Is Grounded.
Trinary Switch: Connect According To Trinary Switch Wiring Diagram.

Circuit Breaker/Battery:
White **Must** Run To (-) Battery. Red May Run To (+) Battery Or Starter. Mount Circuit Breaker As Close to Battery As Possible.

WARNING:
ALWAYS MOUNT CIRCUIT BREAKER AS CLOSE TO THE BATTERY AS POSSIBLE. (NOTE: WIRE BETWEEN BATTERY AND CIRCUIT BREAKER IS UNPROTECTED AND SHOULD BE CAREFULLY ROUTED TO AVOID A SHORT CIRCUIT).



www.vintageair.com

Operation of Controls

On Gen IV systems with three lever/knob controls, the temperature control toggles between heat and A/C operations. To activate A/C, move the temperature lever/knob all the way to cold and then back it off to the desired vent temperature. For heat operation, move the temperature lever/knob all the way to hot and then adjust to the desired vent temperature. The blower will momentarily change speed, each time you toggle between operations, to indicate the change. **NOTE: For proper control panel function, refer to the control panel instructions for calibration procedure.**

Blower Speed

This lever/knob controls blower speed, from OFF to HI.

Mode Control

This lever/knob controls the mode positions, from DASH to FLOOR to DEFROST, with a blend in between.

Temperature Control

This lever/knob controls the temperature, from HOT to COLD.

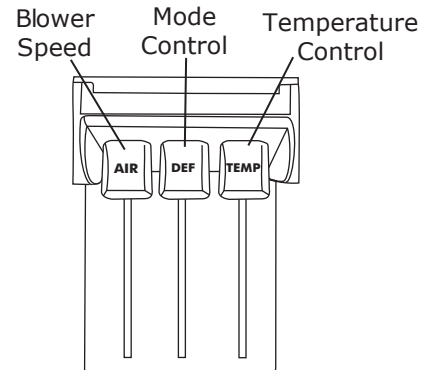

A/C Operation

Blower Speed

Adjust to desired speed.

Mode Control

Adjust to desired mode position (DASH position recommended).

Temperature Control

For A/C operation, adjust to coldest position to engage compressor (Adjust between HOT and COLD to reach desired temperature).

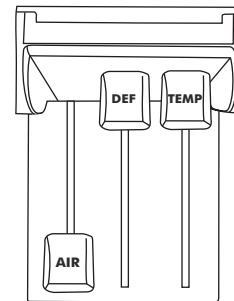

Heat Operation

Blower Speed

Adjust to desired speed.

Mode Control

Adjust to desired mode position (FLOOR position recommended).

Temperature Control

For maximum heating, adjust to hottest position (Adjust between HOT and COLD to reach desired temperature).

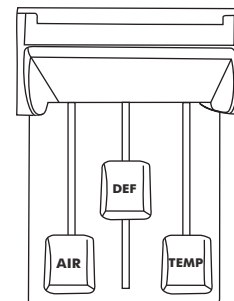

Defrost/De-fog Operation

Blower Speed

Adjust to desired speed.

Temperature Control

Adjust to desired temperature.

Mode Control

Adjust to DEFROST position for maximum defrost, or between FLOOR and DEFROST positions for a bi-level blend (Compressor is automatically engaged).

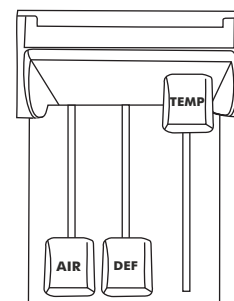



www.vintageair.com

Troubleshooting Guide

Symptom	Condition	Checks	Actions	Notes
1a. Blower stays on high speed when ignition is on.	No other functions work.	Check for damaged pins or wires in control head plug.	Verify that all pins are inserted into plug. Ensure that no pins are bent or damaged in ECU.	Loss of ground on this wire renders control head inoperable.
	All other functions work.	Check for damaged ground wire (white) in control head harness. Check for damaged blower switch or potentiometer and associated wiring.	Verify continuity to chassis ground with white control head wire at various points.	See blower switch check procedure.
1b. Blower stays on high speed when ignition is on or off.		Unplug 3-wire BSC control connector from ECU. If blower shuts off, ECU is either improperly wired or damaged.	Be sure the small, 20 GA white ground wire is connected to the battery ground post. If it is, replace the ECU.	
		Unplug 3-wire BSC control connector from ECU. If blower stays running, BSC is either improperly wired or damaged.	Check to ensure that no BSC wiring is damaged or shorted to vehicle ground. The BSC operates the blower by ground side pulse width modulation switching. The positive wire to the blower will always be hot. If the "ground" side of the blower is shorted to chassis ground, the blower will run on HI. Replace BSC (This will require removal of evaporator from vehicle).	No other part replacements should be necessary.
2. Compressor will not turn on (All other functions work).	System is not charged.	System must be charged for compressor to engage.	Charge system or bypass pressure switch.	Danger: Never bypass safety switch with engine running. Serious injury can result.
	System is charged.	Check for faulty A/C potentiometer or associated wiring (Not applicable to 3-pot controls). Check for disconnected or faulty thermistor.	Check continuity to ground on white control head wire. Check for 5V on red control head wire. Check 2-pin connector at ECU housing.	To check for proper pot function, check voltage at white/blue wire. Voltage should be between 0V and 5V, and will vary with pot lever position. Disconnected or faulty thermistor will cause compressor to be disabled.
3. Compressor will not turn off (All other functions work).		Check for faulty A/C potentiometer or associated wiring.	Repair or replace pot/control wiring.	Red wire at A/C pot should have approximately 5V with ignition on. White wire will have continuity to chassis ground. White/Blue wire should vary between 0V and 5V when lever is moved up or down.
		Check for faulty A/C relay.	Replace relay.	



www.vintageair.com

Troubleshooting Guide (Cont.)

Symptom	Condition	Checks	Actions	Notes
4. System will not turn on, or runs intermittently.	Works when engine is not running; shuts off when engine is started (Typically early Gen IV, but possible on all versions).	Noise interference from either ignition or alternator.	Install capacitors on ignition coil and alternator. Ensure good ground at all points. Relocate coil and associated wiring away from ECU and ECU wiring. Check for burned or loose plug wires.	Ignition noise (radiated or conducted) will cause the system to shut down due to high voltage spikes. If this is suspected, check with a quality oscilloscope. Spikes greater than 16V will shut down the ECU. Install a radio capacitor at the positive post of the ignition coil (See radio capacitor installation bulletin). A faulty alternator or worn out battery can also result in this condition.
	Will not turn on under any conditions.	Verify connections on power lead, ignition lead, and both white ground wires.	Check for positive power at heater valve green wire and blower red wire. Check for ground on control head white wire.	
		Verify battery voltage is greater than 10 volts and less than 16.	Verify proper meter function by checking the condition of a known good battery.	
5. Loss of mode door function.	No mode change at all.	Check for damaged mode switch or potentiometer and associated wiring.		Typically caused by evaporator housing installed in a bind in the vehicle. Be sure all mounting locations line up and don't have to be forced into position.
	Partial function of mode doors.	Check for obstructed or binding mode doors.		
		Check for damaged stepper motor or wiring.		
6. Blower turns on and off rapidly.	Battery voltage is at least 12V.	Check for at least 12V at circuit breaker.	Ensure all system grounds and power connections are clean and tight.	System shuts off blower at 10V. Poor connections or weak battery can cause shutdown at up to 11V.
	Battery voltage is less than 12V.	Check for faulty battery or alternator.	Charge battery.	
7. Erratic functions of blower, mode, temp, etc.		Check for damaged switch or pot and associated wiring.	Repair or replace.	
		This is an indicator that the system has been reset. Be sure the red power wire is on the battery post, and not on a switched source. Also, if the system is pulled below 7V for even a split second, the system will reset.	Run red power wire directly to battery.	



Packing List: Evaporator Kit (561065)

No.	Qty.	Part No.	Description
1.	1	744004-VUE	Gen IV Magnum Evaporator Sub Case
2.	1	784159	Accessory Kit

Checked By: _____
 Packed By: _____
 Date: _____

1

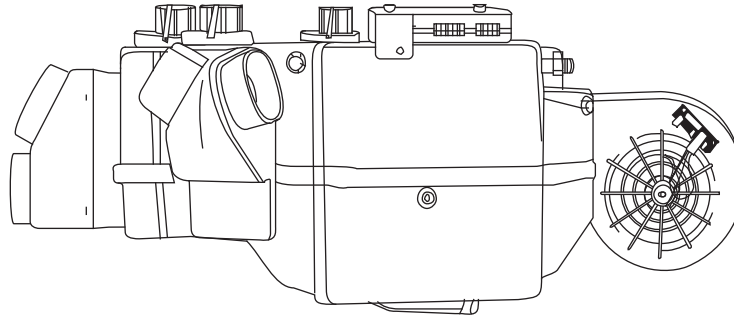

**Gen IV Magnum
Evaporator Sub Case
744004-VUE**

2

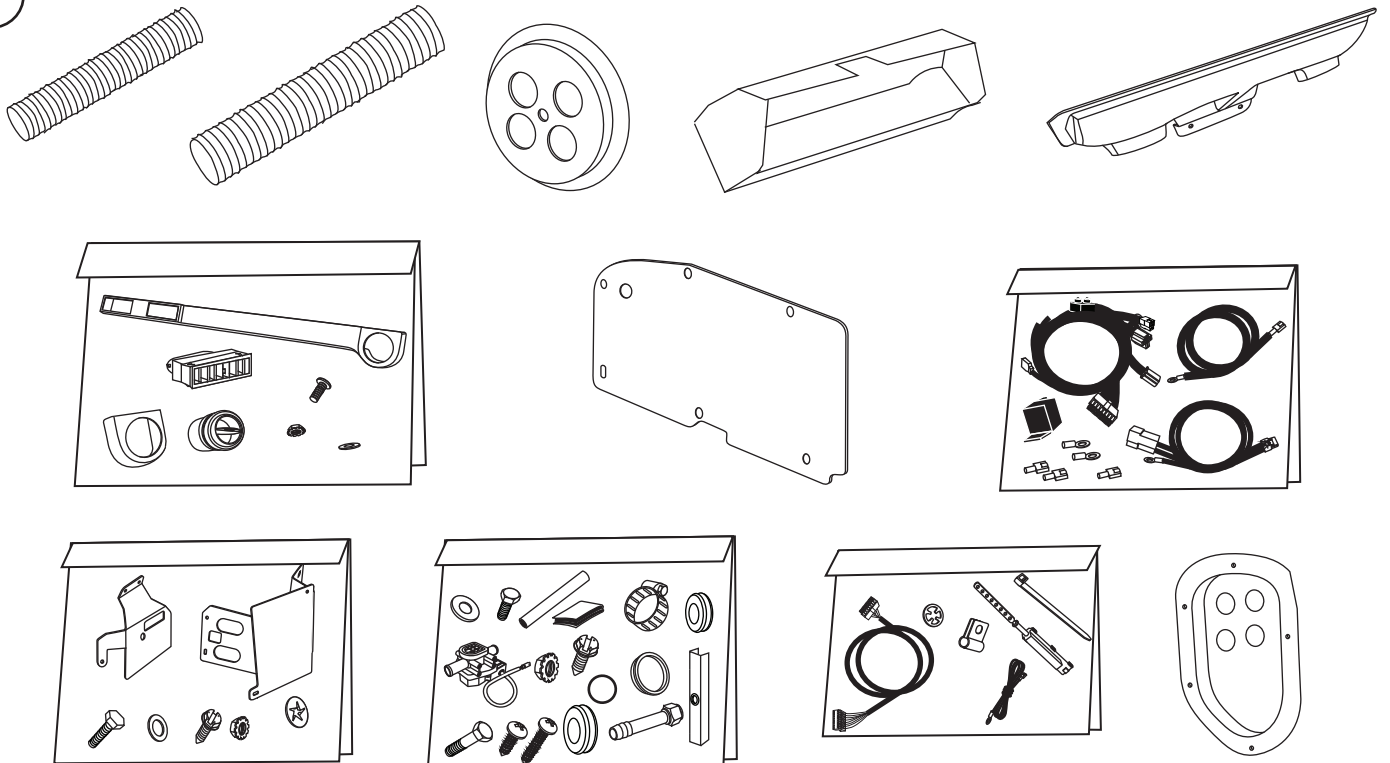

**Accessory Kit
784159**

**NOTE: Images may not depict actual parts and quantities.
Refer to packing list for actual parts and quantities.**