

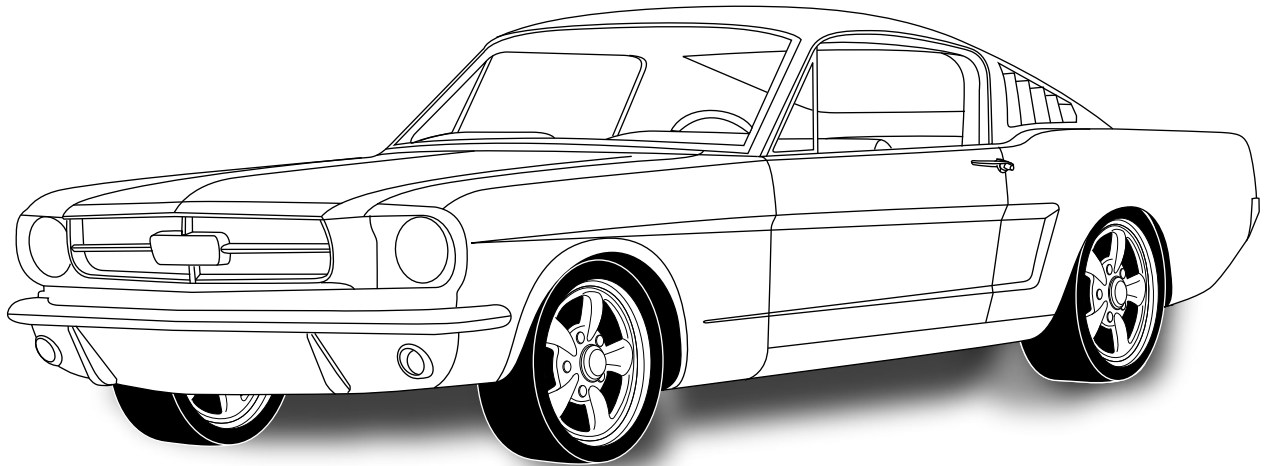

an ISO 9001:2008 Registered Company

1964 ½-66 Ford Mustang

Evaporator Kit
(554164)



18865 Goll St. San Antonio, TX 78266
Phone: 210-654-7171
Fax: 210-654-3113
www.vintageair.com



www.vintageair.com

Table of Contents

Thank you for purchasing this evaporator kit from Vintage Air. When installing these components as part of a complete SureFit™ system, Vintage Air recommends working from front to back on the vehicle, installing the condenser kit, hose kit, and compressor first, followed by the wiring, evaporator, and finally the control panel.

- Cover..... 1
- Table of Contents..... 2
- Packing List/Parts Disclaimer..... 3
- Information Page..... 4
- Wiring Notice..... 5
- Engine Compartment Disassembly, Condenser Assembly and Installation, Compressor and Brackets..... 6
- Passenger Compartment Disassembly..... 7
- Defrost Duct and Fresh Air Cap Installation..... 8
- Passenger Side Evaporator Rear Bracket Template Instructions, Driver Side Evaporator Rear Bracket Template Instructions..... 9
- Firewall Cover Installation..... 10
- Evaporator Installation..... 11
- Drain Hose Installation, Lubricating O-rings, A/C Hose Installation..... 12
- Heater Hose & Heater Control Valve Installation..... 13
- Driver Side A/C and Heater Hose Routing..... 14
- Passenger Side A/C and Heater Hose Routing..... 15
- Center Louver Installation (without Center Console), Center Louver Installation (with Center Console)..... 16
- Driver & Passenger Side Under Dash Louver Installation..... 17
- Final Steps..... 18
- Control Panel & Duct Hose Routing..... 19
- Evaporator Hardline Installation..... 20
- Wiring Diagram..... 21
- Gen IV Wiring Connection Instruction..... 22
- Operation of Controls..... 23
- Troubleshooting Guide..... 24
- Troubleshooting Guide (Cont.)..... 25
- Passenger Side Evaporator Rear Bracket Template..... 26
- Driver Side Evaporator Rear Bracket Template..... 27
- Center Console Modification Template..... 28
- Packing List..... 29



www.vintageair.com

Packing List: Evaporator Kit (554164)

No.	Qty.	Part No.	Description
1.	1	744004-VUE	Gen IV 4-Vent Evaporator Sub Case
2.	1	781066	Accessory Kit

**** Before beginning installation, open all packages and check contents of shipment. Please report any shortages directly to Vintage Air within 15 days. After 15 days, Vintage Air will not be responsible for missing or damaged items.**

1

Gen IV 4-Vent Evaporator
Sub Case
744004-VUE

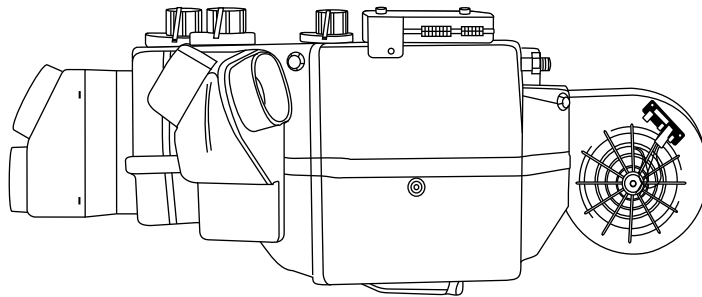

2

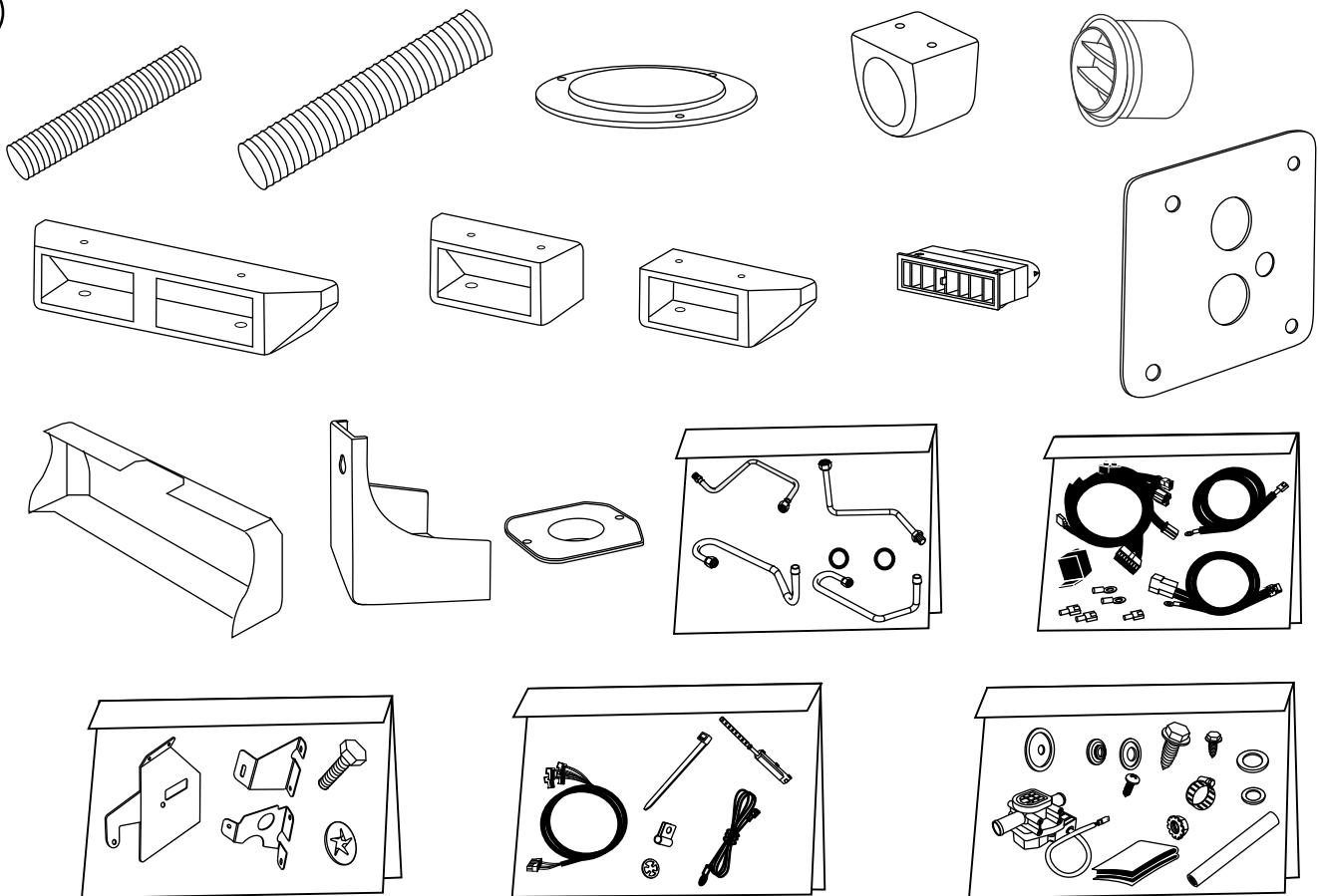

Accessory Kit
781066

NOTE: Images may not depict actual parts and quantities. Refer to packing list for actual parts and quantities.



www.vintageair.com

Important Notice—Please Read

For Maximum System Performance, Vintage Air Recommends the Following:

NOTE: Vintage Air systems are designed to operate with R134a refrigerant only. Use of any other refrigerant could damage your A/C system and/or vehicle, and possibly cause a fire, in addition to potentially voiding the warranties of the A/C system and its components.

Refrigerant Capacities:

Vintage Air System: 1.8 lbs. (28.8 oz.) or 816 grams of **R134a**, charged by weight with a quality charging station or scale. **NOTE: Use of the proper type and amount of refrigerant is critical to system operation and performance.**

Other Systems: Consult manufacturer's guidelines.

Lubricant Capacities:

New Vintage Air-Supplied Sanden Compressor: No additional oil needed (Compressor is shipped with proper oil charge).

All Other Compressors: Consult manufacturer (Some compressors are shipped dry and will need oil added).

Safety Switches

Your Vintage Air system is equipped with a binary pressure safety switch. A binary switch disengages the compressor clutch in cases of extreme low pressure conditions (refrigerant loss) or excessively high head pressure (406 PSI) to prevent compressor damage or hose rupture. A trinary switch combines Hi/Lo pressure protection with an electric fan operation signal at 254 PSI, and should be substituted for use with electric fans. Compressor safety switches are extremely important since an A/C system relies on refrigerant to circulate lubricant.

Service Info:

Protect Your Investment: Prior to assembly, it is critical that the compressor, evaporator, A/C hoses and fittings, hardlines, condenser and receiver/drier remain capped. Removing caps prior to assembly will allow moisture, insects and debris into the components, possibly leading to reduced performance and/or premature failure of your A/C system. This is especially important with the receiver/drier.

Additionally, when caps are removed for assembly, **BE CAREFUL!** Some components are shipped under pressure with dry nitrogen.

Evacuate the System for 35-45 Minutes: Ensure that system components (Drier, compressor, evaporator and condenser) are at a temperature of at least 85°F. On a cool day, the components can be heated with a heat gun **or** by running the engine with the heater on before evacuating. Leak check and charge to specifications.

Bolts Passing Through Cowl and/or Firewall:

To ensure a watertight seal between the passenger compartment and the vehicle exterior, for all bolts passing through the cowl and/or firewall, Vintage Air recommends coating the threads with silicone prior to installation.

Heater Hose (not included with this kit):

Heater hose may be purchased from Vintage Air (Part#31800-VUD) or your local parts retailer. Routing and required length will vary based on installer preference.



www.vintageair.com

Important Wiring Notice—Please Read

Some vehicles may have had some or all of their radio interference capacitors removed. There should be a capacitor found at each of the following locations:

- 1. On the positive terminal of the ignition coil.**
- 2. If there is a generator, on the armature terminal of the generator.**
- 3. If there is a generator, on the battery terminal of the voltage regulator.**

Most alternators have a capacitor installed internally to eliminate what is called “whining” as the engine is revved. If whining is heard in the radio, or just to be extra cautious, a radio interference capacitor can be added to the battery terminal of the alternator.

It is also important that the battery lead is in good shape and that the ground leads are not compromised. There should be a heavy ground from the battery to the engine block, and additional grounds to the body and chassis.

If these precautions are not observed, it is possible for voltage spikes to be present on the battery leads. These spikes come from ignition systems and charging systems, and from switching some of the vehicle’s other systems on and off. Modern computer-operated equipment can be sensitive to voltage spikes on the power leads, which can cause unexpected resets, strange behavior and/or permanent damage.

Vintage Air strives to harden our products against these types of electrical noise, but there is a point where a vehicle’s electrical system can be degraded so much that nothing can help.

Radio interference capacitors should be available at most auto and truck parts suppliers. They typically are cylindrical in shape, a little over an inch long and a little over a half-inch in diameter, and they have a single lead coming from one end of the cylinder with a terminal on the end of the wire, as well as a mounting clip which is screwed into a good ground on the vehicle. The specific value of the capacitance is not too significant in comparison to ignition capacitors that are matched with the coil to reduce pitting of the points.

- Care must be taken, when installing the compressor lead, not to short it to ground. The compressor lead must not be connected to a condenser fan or to any other auxiliary device. Shorting to ground or connecting to a condenser fan or any other auxiliary device may damage wiring or the compressor relay, and/or cause a malfunction.
- When installing ground leads on Gen IV systems, the blower control ground and ECU ground must be connected directly to the negative battery post.
- For proper system operation, the heater control valve must be connected to the ECU.



www.vintageair.com

Engine Compartment Disassembly

NOTE: Before starting the installation, check the function of the vehicle (horn, lights, etc.) for proper operation, and study the instructions, illustrations, & diagrams.

Perform the Following:

1. Disconnect battery.
2. Remove battery (retain).
3. Drain radiator.
4. Remove radiator (retain).
5. Evacuate the A/C system if necessary.
6. Remove the OEM condenser and drier (discard) (See Figure 1, below).
7. Remove the OEM compressor and bracket (discard) (See Figure 1, below).
8. Remove the OEM heater & A/C hoses (discard) (See Figure 1, below).

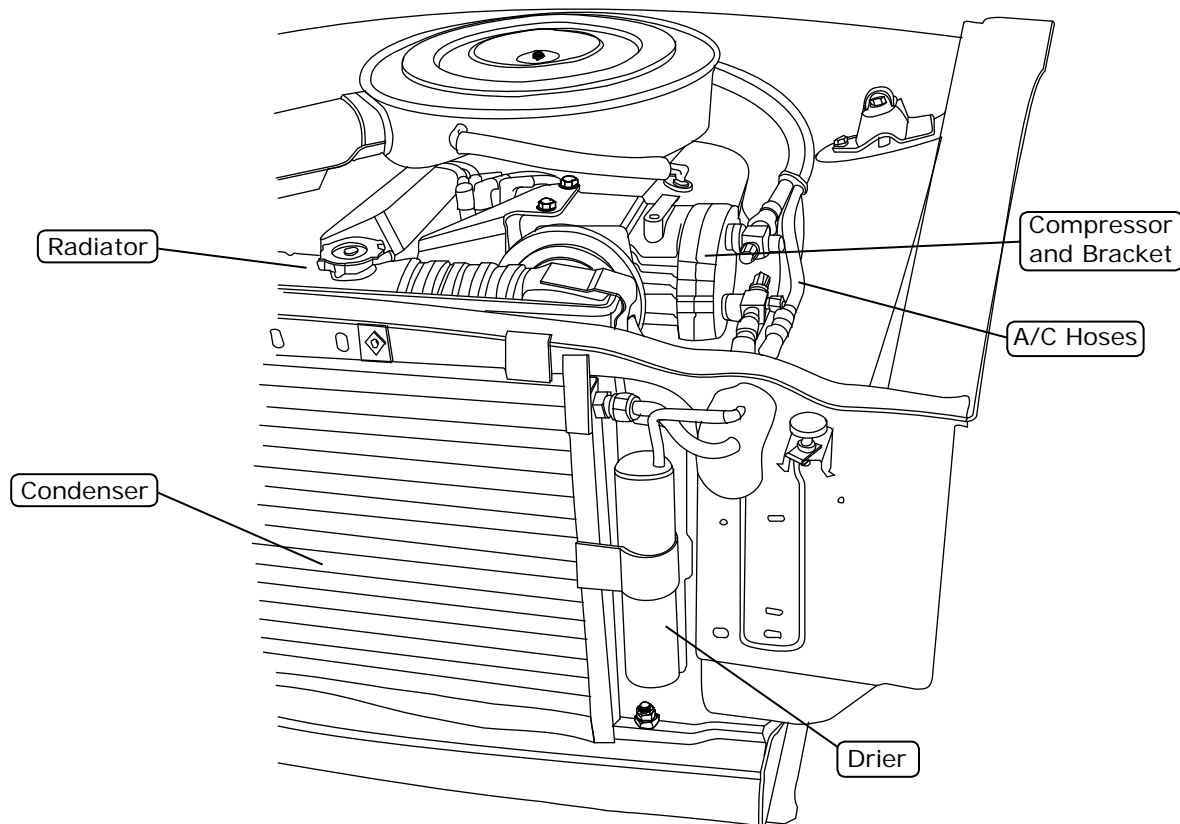

Figure 1

Condenser Assembly and Installation

1. Refer to separate instructions included with the condenser kit to install the condenser.
2. Binary switch installation (Refer to condenser instructions).

Compressor and Brackets

1. Refer to separate instructions included with the bracket kit to install the compressor bracket.



www.vintageair.com

Passenger Compartment Disassembly

Perform the Following:

1. Remove the glove box door (retain) (See Figure 2, below).
2. Remove the glove box (discard).
3. Remove the center console (if equipped).
4. Remove the under dash A/C evaporator (if equipped) (See Figure 2, below).
5. Remove the OEM heater assembly (discard) (See Figure 2a, below).
6. Remove the driver side fresh air assembly and cable (discard) (See Figure 2a, below).
7. Remove the OEM control panel assembly (retain) (See Figure 2a, below). **NOTE: Refer to control panel conversion kit instructions for installation of controls.**
8. Remove the radio (retain).
9. Remove the speaker grille (retain) (See Figure 2a, below).
10. Remove the OEM defrost ducts and all related ducting (See Figure 2a, below).

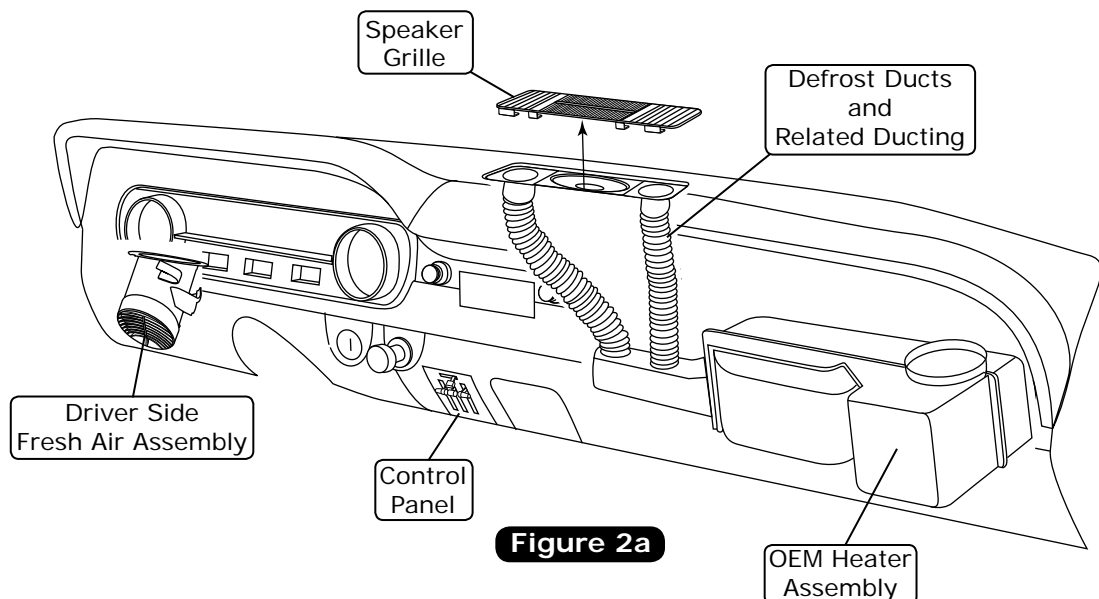
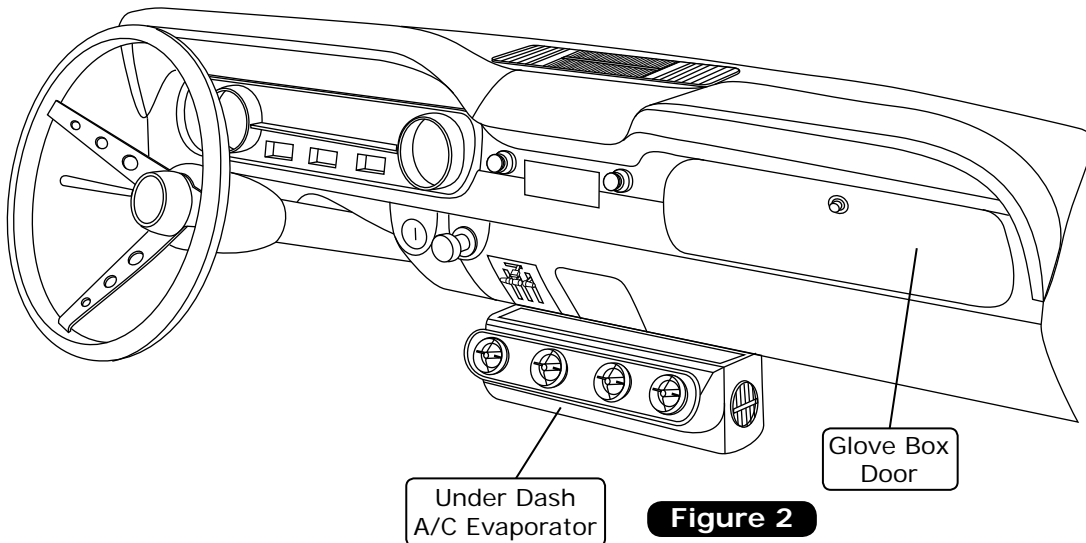



www.vintageair.com

Defrost Duct and Fresh Air Cap Installation

1. Install the defrost ducts into the dash using the OEM mounting clips (See Figure 3, below).
2. Reinstall the speaker grille (See Figure 3, below).
3. Hold the fresh air cap under the dash, and mark the (3) mounting holes (passenger side only).
4. Drill (3) 1/8" mounting holes under the dash (passenger side only) (See Figure 3, below).
5. Apply a 1/4" bead of silicone around the mating surface of the passenger side fresh air cap (See Figure 3, below).
6. Secure the passenger side fresh air cap to the fresh air hole using (3) #10 x 1/2" sheet metal screws as shown in Figure 3, below.
7. Apply a 1/4" bead of silicone around the mating surface of the driver side fresh air cap (See Figure 3, below).
8. Install the driver side fresh air cap using (3) OEM nuts as shown in Figure 3, below.

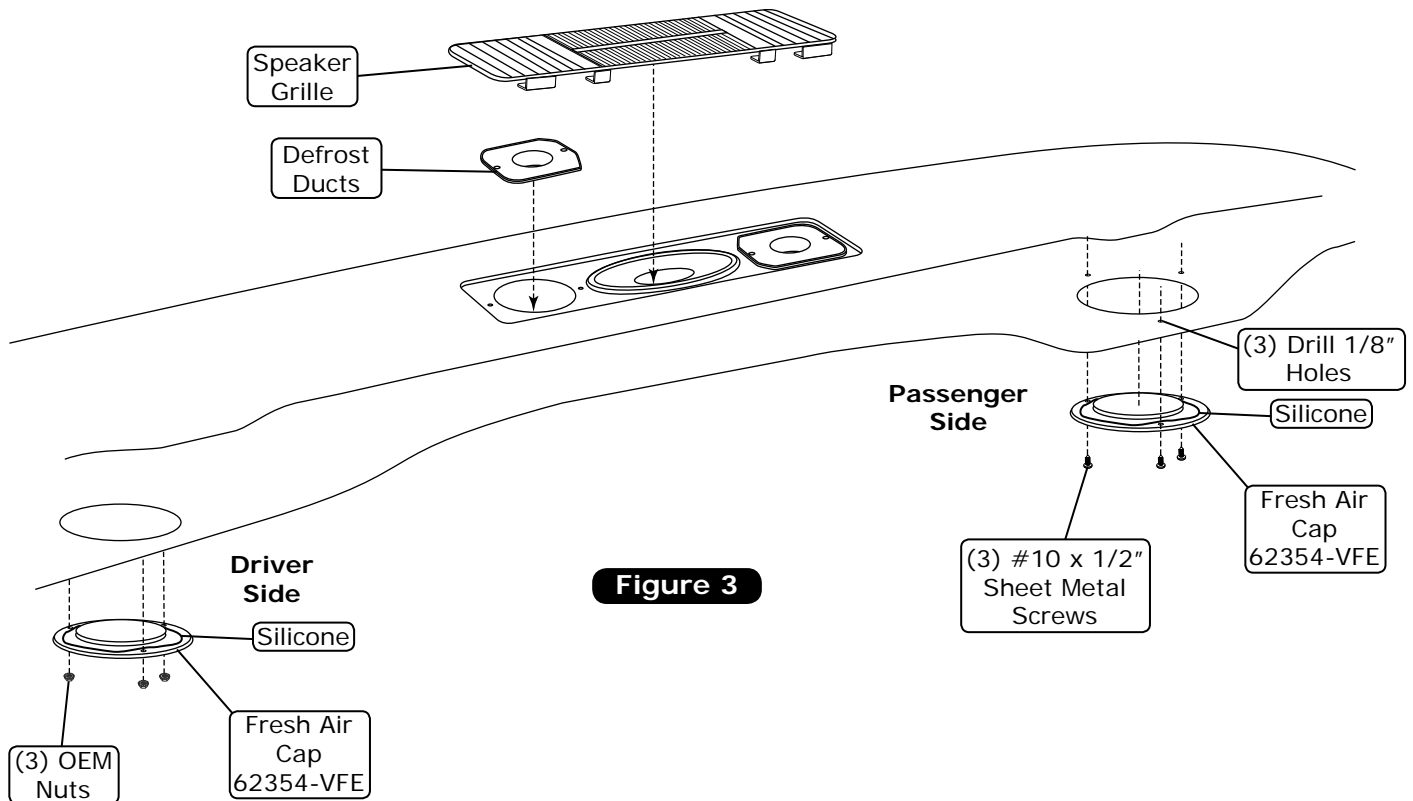

Figure 3



www.vintageair.com

Passenger Side Evaporator Rear Bracket Template Instructions

1. Cut out passenger side evaporator rear bracket template on Page 26.
2. Align the template with the (4) OEM holes as shown in Figure 4, below. Drill a 9/32" hole as indicated on the template.

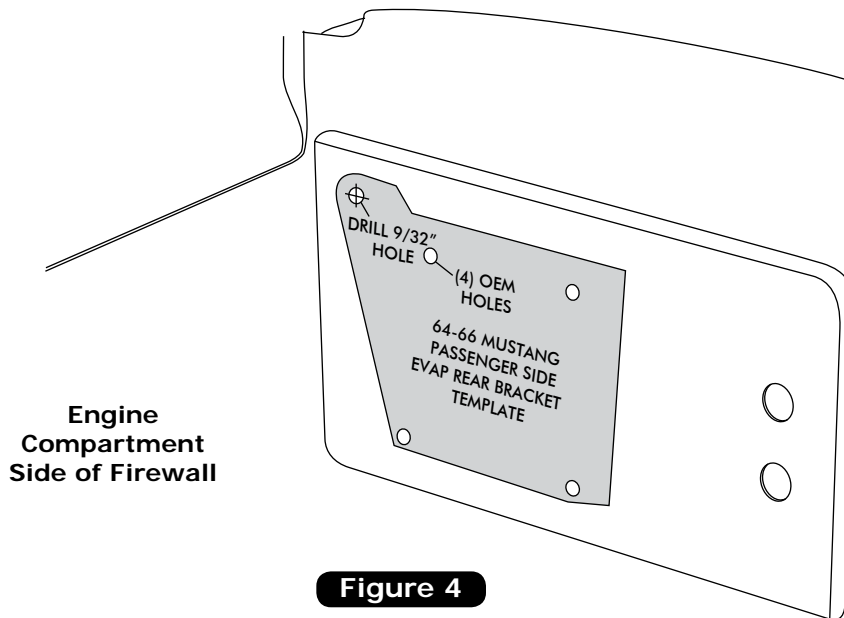

Figure 4

Driver Side Evaporator Rear Bracket Template Instructions

1. Cut out the driver side evaporator rear bracket template on Page 27.
2. Align the template with the OEM heater outlet holes as shown in Figure 5, below. Drill a 9/32" hole as indicated on the template.

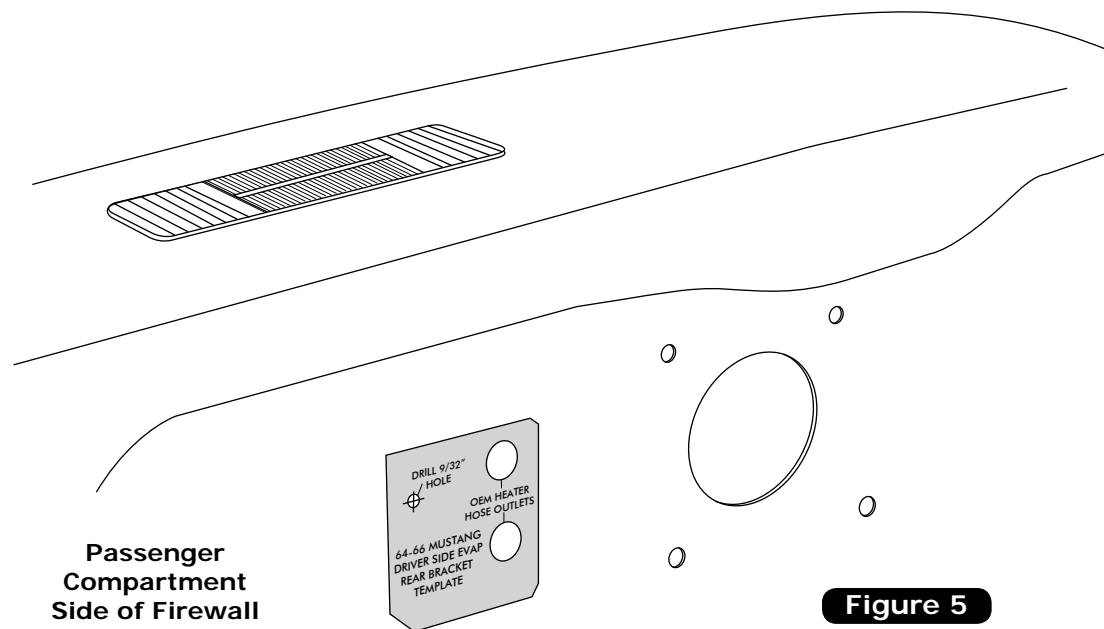

Figure 5



www.vintageair.com

Firewall Cover Installation

1. Install (3) grommets onto the firewall cover as shown in Figure 5, below.
2. Apply a 1/4" bead of silicone around the mating surface of the firewall cover as shown in Figure 6a, below.
3. Secure the firewall cover to the firewall using (4) 1/4-20 x 1" hex bolts, flat washers and nuts (See Figure 6, below). **NOTE: Firewall cover installs from inside passenger side compartment.**

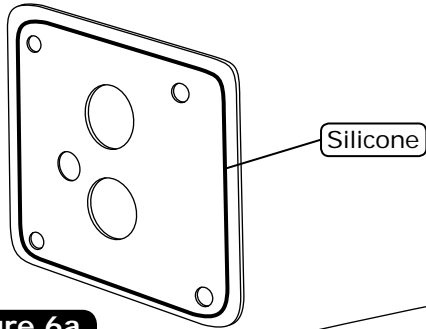

Figure 6a

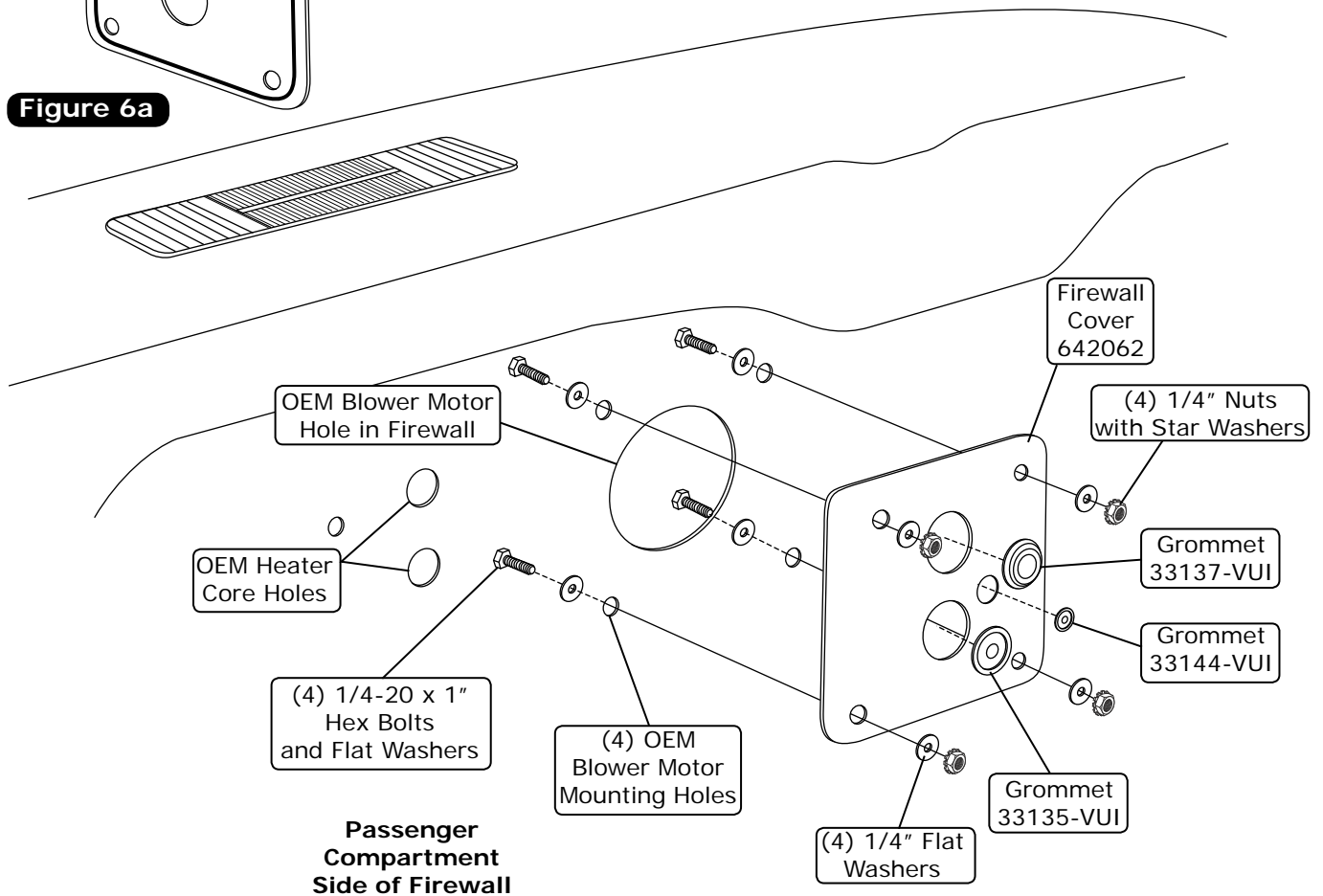

Figure 6



www.vintageair.com

Evaporator Installation

NOTE: To ensure a watertight seal between the passenger compartment and the vehicle exterior, for all bolts passing through the firewall, Vintage Air recommends coating the threads with silicone prior to installation.

1. On a workbench, install the evaporator rear brackets and hardlines with properly lubricated O-rings (See Figure 9, Page 12, and Figure 19, Page 20).
2. Install the front mounting bracket onto the evaporator using (2) 1/4-20 x 1/2" hex bolts, and tighten as shown in Figure 7, below.
3. Lift the evaporator unit up under the dashboard. Secure loosely to the firewall from the engine compartment side using (2) 1/4-20 nuts and washers (See Figure 7a, below). **NOTE: To ensure proper drainage, it is very important that the evaporator is level, both left-right and fore-aft. Check for level on the flat portions of the case around the drain.**
4. Using the front evaporator bracket as a guide, mark and drill (2) 3/16" holes in the cowl (See Figure 7b, below).
5. Using (2) #14 x 3/4" sheet metal screws, secure the front evaporator mounting bracket to the inner cowl (See Figure 7b, below).
6. Verify that the evaporator unit is level and square to the dash; then tighten all mounting bolts. **NOTE: Tighten the bolt on the firewall first. Then tighten the front mounting bracket sheet metal screws.**

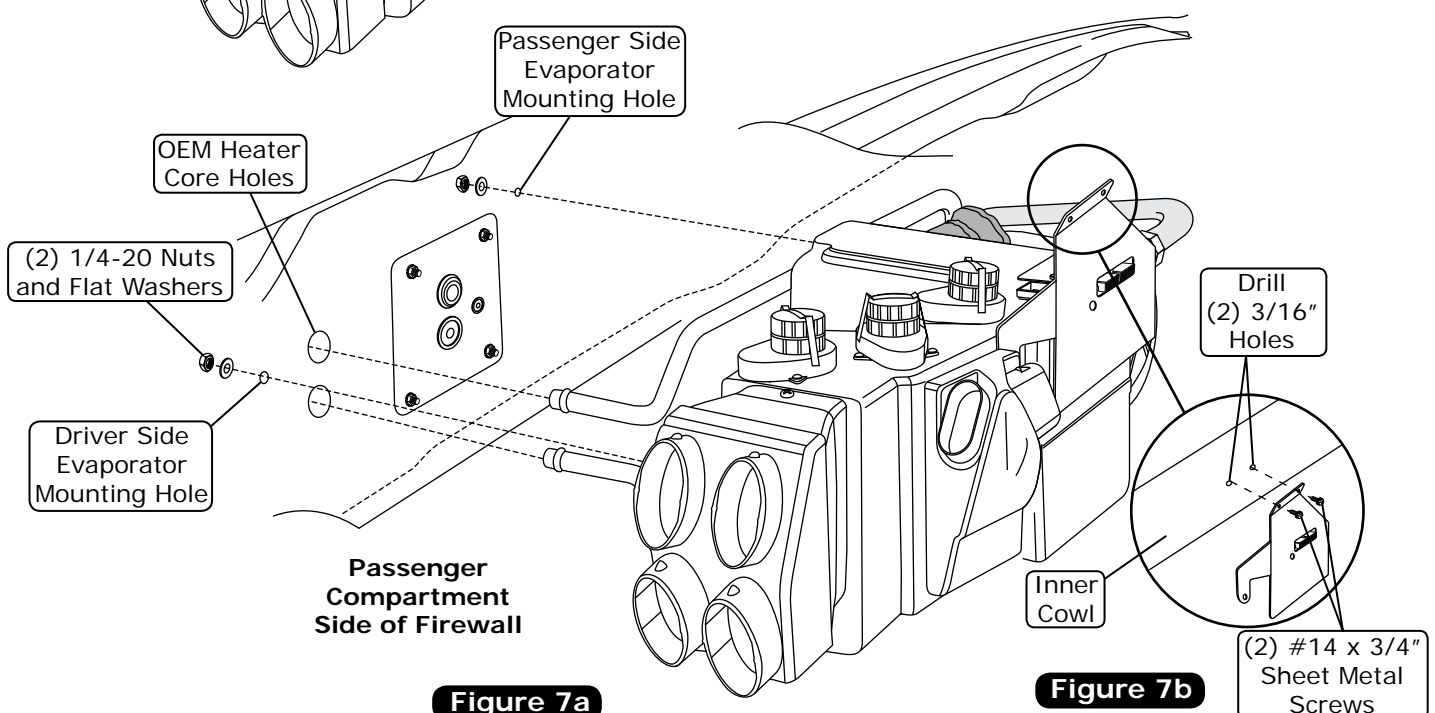
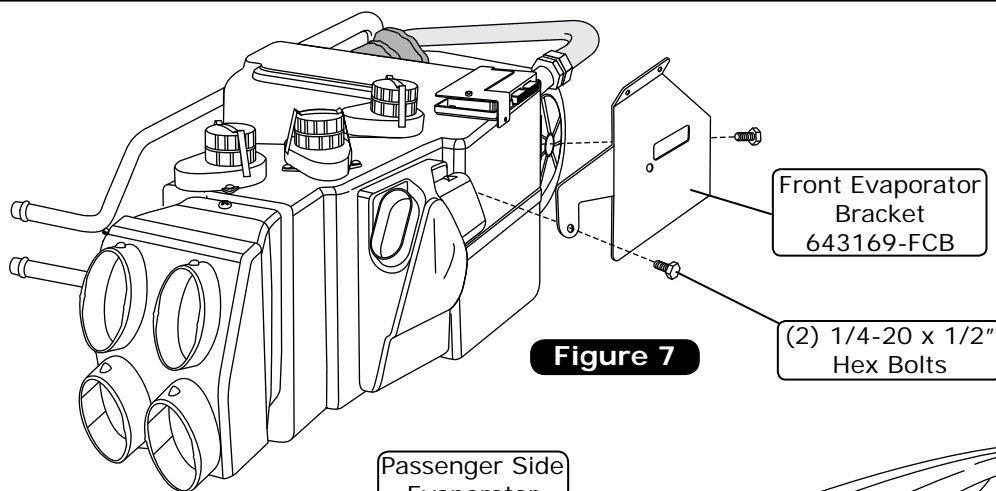



www.vintageair.com

Drain Hose Installation

1. Locate the evaporator drain on the bottom of the evaporator case.
2. In line with the drain, lightly make a mark on the firewall. Then, measure 1" down and drill a 5/8" hole through the firewall (See Figure 8, below).
3. Install the drain hose onto the evaporator drain on the bottom of the unit, and route it through the firewall.
4. Install a 1/2" 90° drain elbow onto the drain hose (See Figure 8, below).

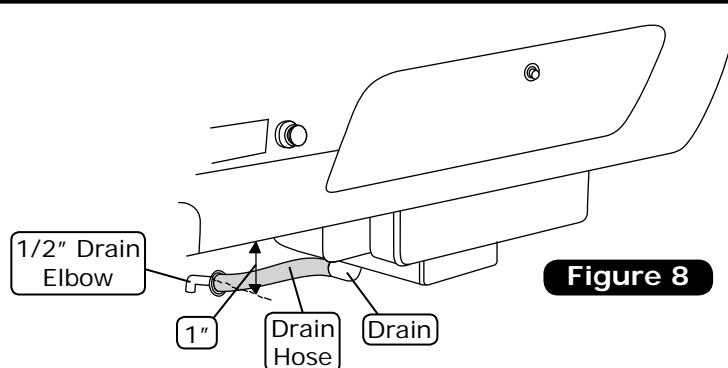
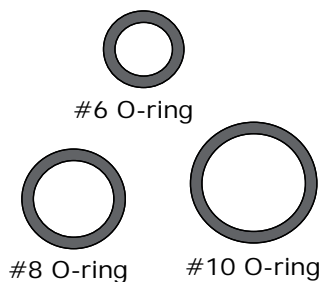

Figure 8

Lubricating O-rings



NOTE: Standard torque specifications:

- #6: 11 to 13 ft-lb.
- #8: 15 to 20 ft-lb.
- #10: 21 to 27 ft-lb.

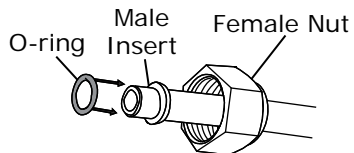

For a proper seal of fittings: Install supplied O-rings as shown and lubricate with supplied oil.

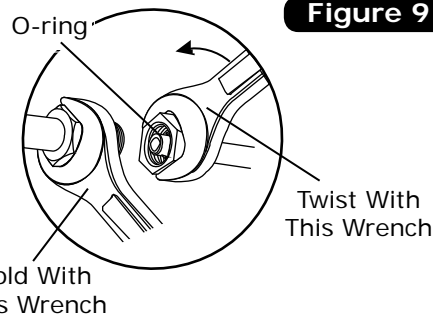
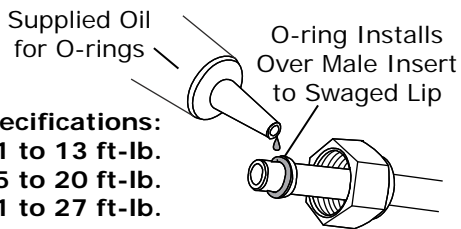

Figure 9

A/C Hose Installation

Standard Hose Kit:

1. Locate the #8 compressor A/C hose. Lubricate (2) #8 O-rings (See Figure 9, above) and connect the 45° fitting to the #8 discharge port on the compressor. Then route the straight female fitting with service port to the #8 condenser hardline coming through the radiator core support (See Figure 11, Page 14). Tighten each fitting connection as shown in Figure 9, above.
2. Locate the #10 compressor A/C hose. Lubricate (2) #10 O-rings (See Figure 9, above) and connect the 90° female fitting with service port to the #10 suction port on the compressor. Then route the 90° female fitting to the #10 evaporator hardline coming through the firewall (See Figure 10, Page 13, & Figure 11, Page 14). Tighten each fitting connection as shown in Figure 9, above. Wrap the #10 fitting connections with press tape (See Figure 10, Page 13).
3. Locate the #6 evaporator/drier hose. Lubricate (2) #6 O-rings (See Figure 9, above) and connect the straight female fitting to the #6 drier hardline coming through the radiator core support. Then route the 90° female fitting to the #6 evaporator hardline coming through the firewall (See Figure 10, Page 13). Tighten each fitting connection as shown in Figure 9, above.
4. Use (6) tie wraps to secure the #6 A/C hose to the brace as shown in Figure 11, Page 14.

Modified Hose Kit:

1. Refer to separate instructions included with modified hose kit.



www.vintageair.com

Heater Hose & Heater Control Valve Installation

1. Route a piece of heater hose from the water pump to the lower heater line coming through the firewall as shown in Figure 10, below. Secure using hose clamps.
2. Route a piece of heater hose from the intake to the upper heater line coming through the firewall as shown in Figure 10, below. **NOTE: Install the heater control valve in line with the intake manifold (pressure side) heater hose, and secure using hose clamps. Also note proper flow direction.**

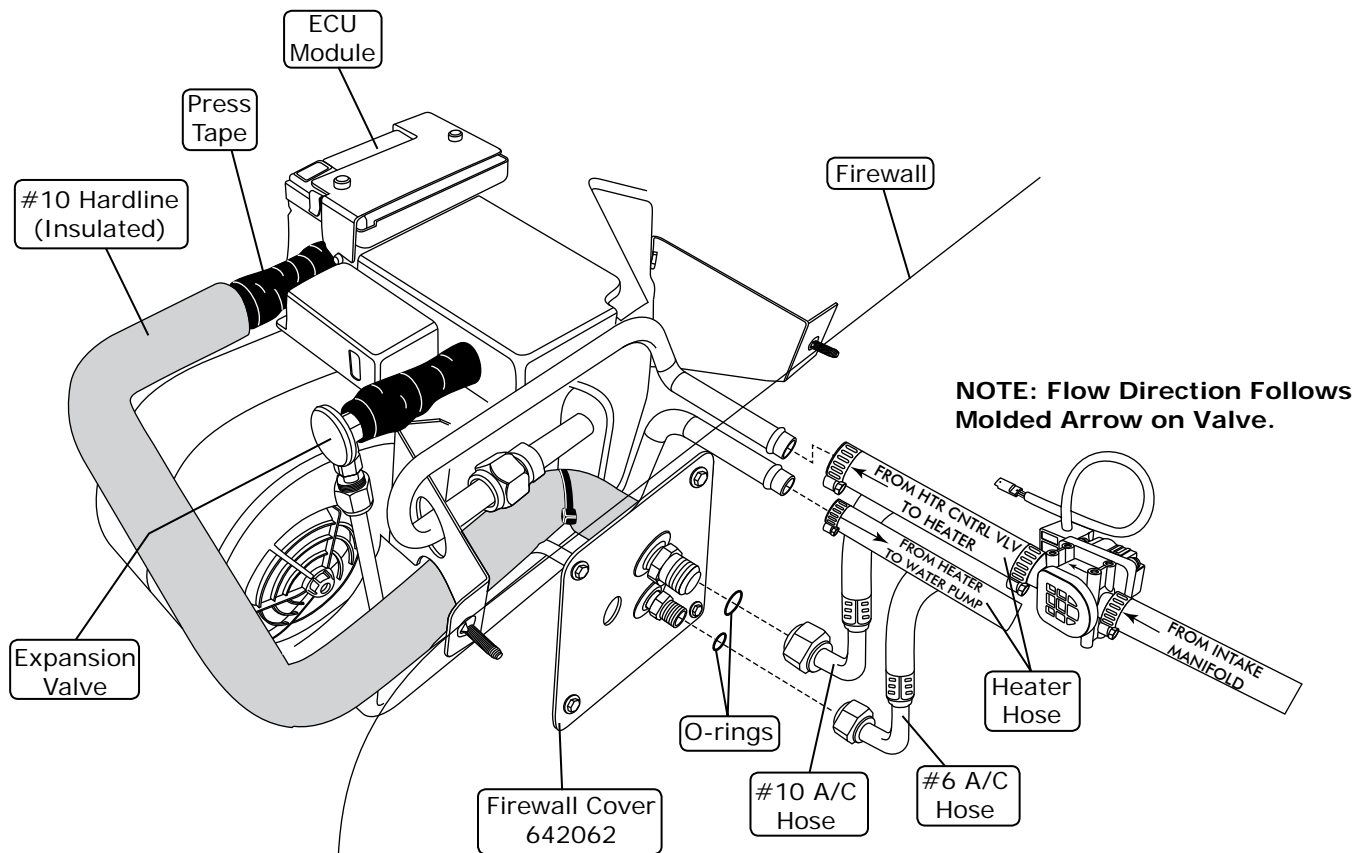

Figure 10



www.vintageair.com

Driver Side A/C and Heater Hose Routing

NOTE: Vintage Air Systems use 5/8" heater connections. On engines equipped with 3/4" hose nipples, these will need to be removed and replaced with 5/8" nipples (not supplied). For water pumps with a cast-in 3/4" heater outlet, a 3/4" x 5/8" reducer fitting (not supplied) will need to be installed in the heater hose.

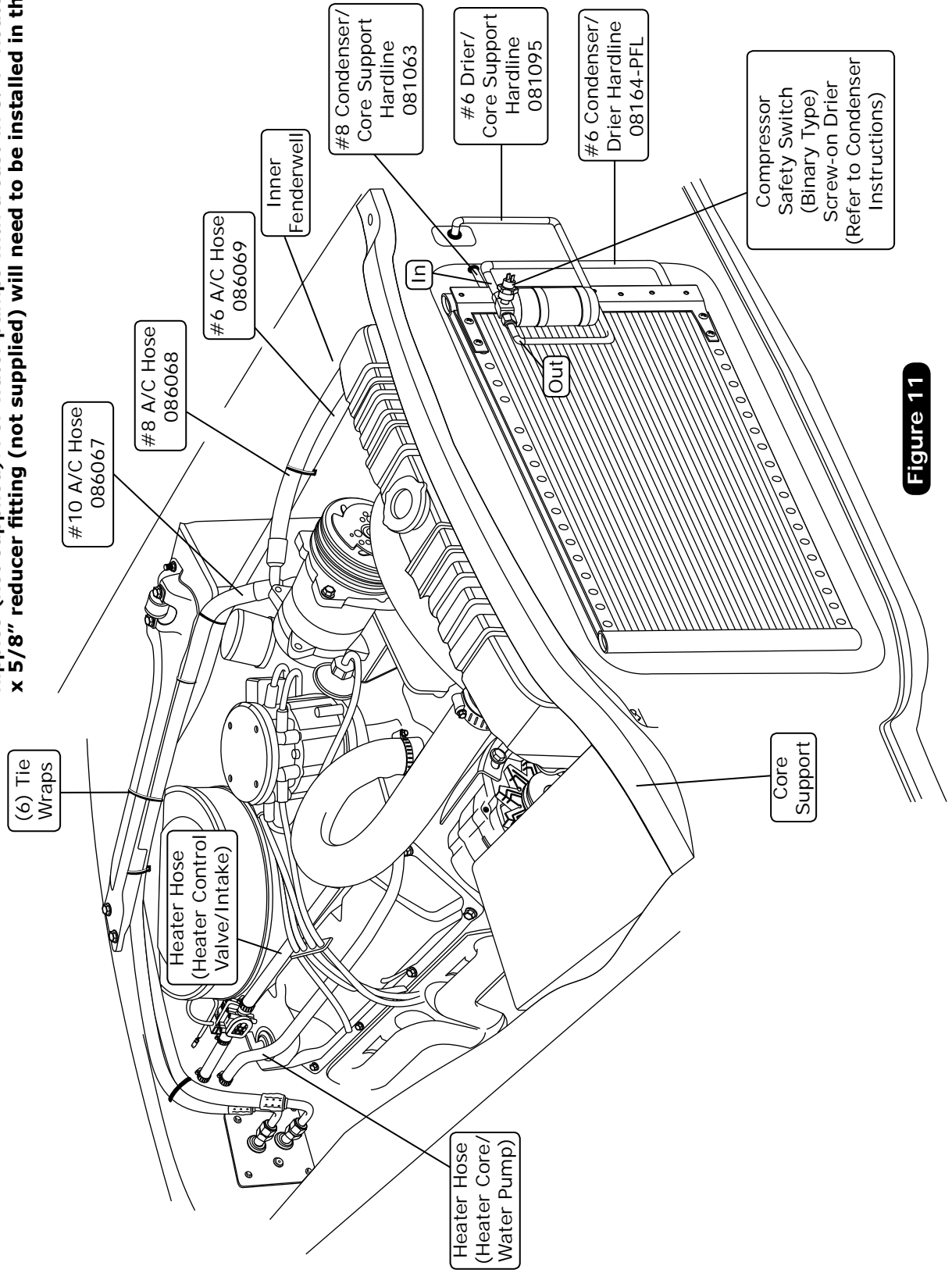

Figure 11



www.vintageair.com

Passenger Side A/C and Heater Hose Routing

NOTE: Vintage Air Systems use 5/8" heater connections. On engines equipped with 3/4" hose nipples, these will need to be removed and replaced with 5/8" nipples (not supplied). For water pumps with a cast-in 3/4" heater outlet, a 3/4" x 5/8" reducer fitting (not supplied) will need to be installed in the heater hose.

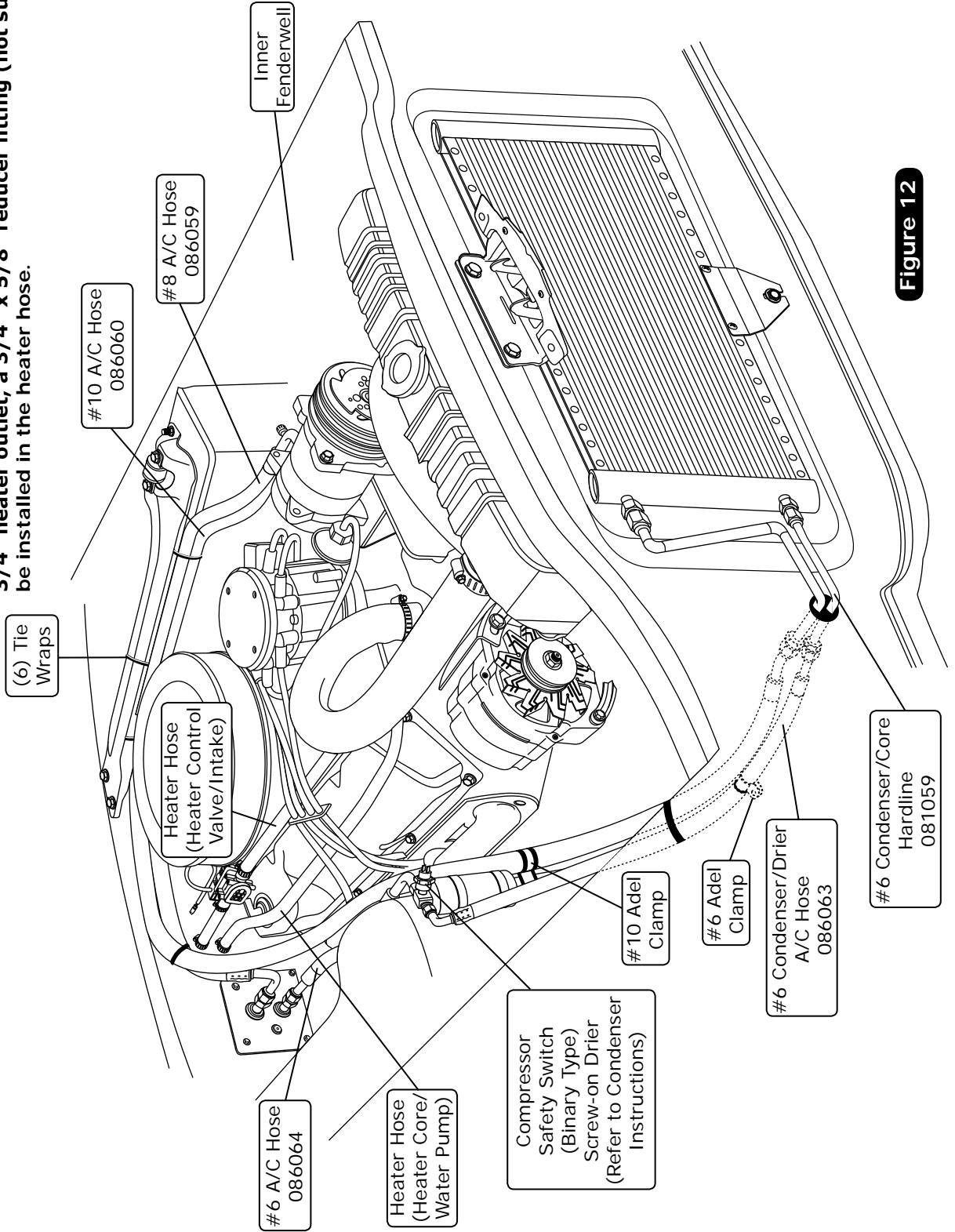

Figure 12



www.vintageair.com

Center Louver Installation (without Center Console)

1. Mount the center louver bezel under the dash using (2) #8 x 1/2" pan head screws as shown in Figure 13, below.
2. Install the louvers into the center louver bezel as shown in Figure 13, below.

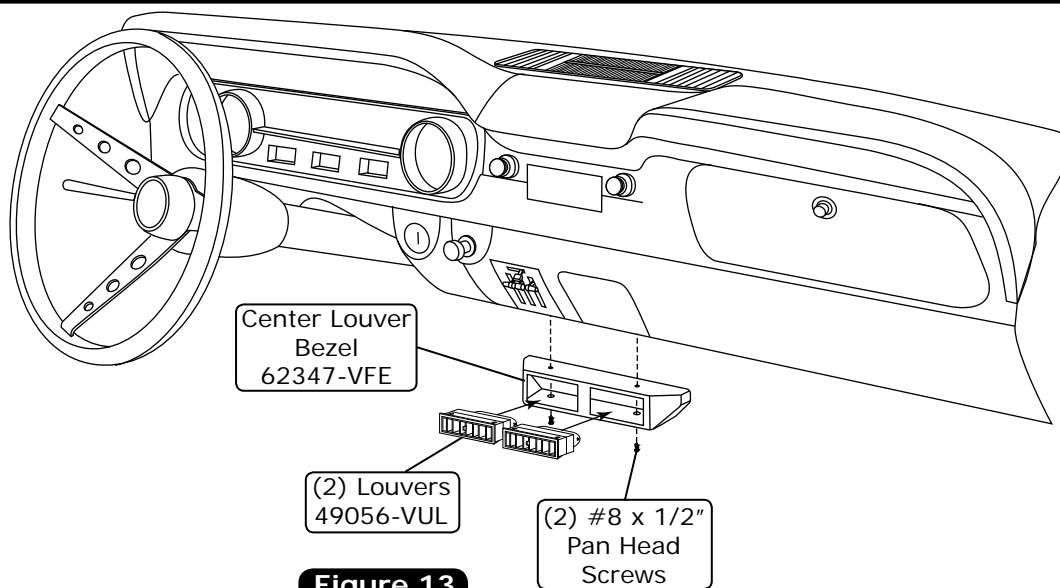

Figure 13

Center Louver Installation (with Center Console)

1. Mount the driver and passenger side center louver bezels under the dash using (4) #8 x 1/2" pan head screws as shown in Figure 14, below.
2. Install the louvers into the center louver bezels as shown in Figure 14, below.

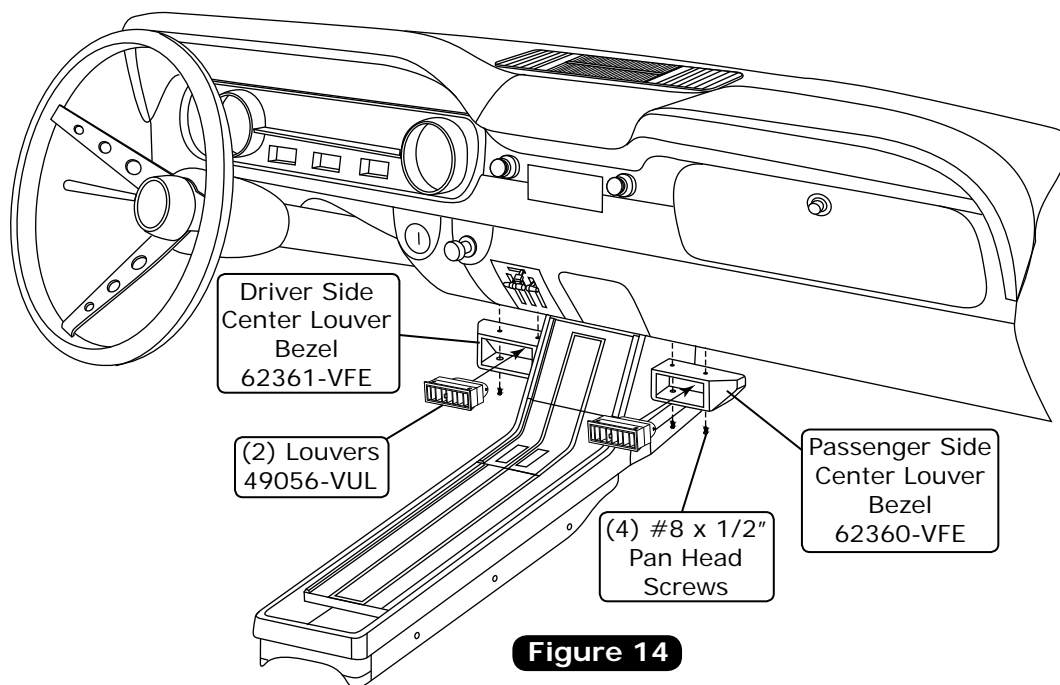

Figure 14



www.vintageair.com

Driver & Passenger Side Under Dash Louver Installation

1. Mount the driver and passenger side louver housings under the dash using (2) #8 x 1/2" pan head screws as shown in Figure 15, below.
2. Install the louvers into the driver and passenger side louver housings as shown in Figure 15, below.

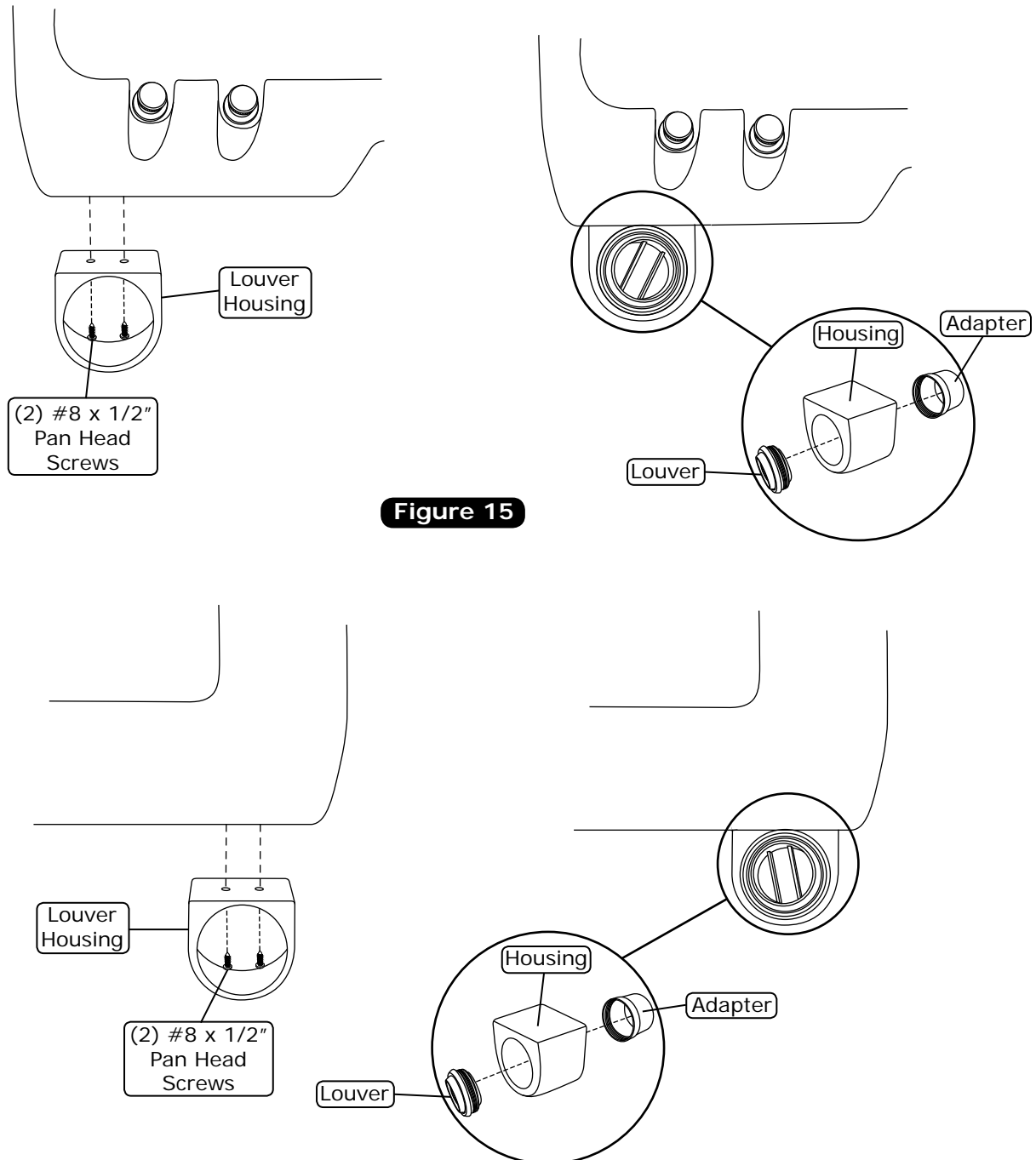

Figure 15



www.vintageair.com

Final Steps

1. Install duct hoses as shown in Figure 18, Page 19.
2. Route A/C wires (12 volt/grounds/binary switch/heater valve) through 3/8" grommet as shown in Figure 16, below.
3. Install the control panel assembly. **NOTE: Controls must be calibrated for proper operation. Refer to control panel instructions.**
4. Plug the wiring harnesses into the ECU module on the sub case. Wire according to the wiring diagrams on Pages 21 and 22.
5. Install the new glove box.
6. Reinstall the glove box door.
7. Using the template provided on Page 28, modify the center console as shown in Figure 17, below.
8. Reinstall all previously removed items.
9. Fill radiator with at least a 50/50 mixture of approved antifreeze and distilled water. It is the owner's responsibility to keep the freeze protection at the proper level for the climate in which the vehicle is operated. Failure to follow antifreeze recommendations will cause heater core to corrode prematurely and possibly burst in A/C mode and/or freezing weather, voiding your warranty.
10. Double check all fittings, brackets and belts for tightness.
11. Vintage Air recommends that all A/C systems be serviced by a licensed automotive A/C technician.
12. Evacuate the system for a minimum of 45 minutes prior to charging, and perform a leak check prior to servicing.
13. Charge the system to the capacities stated on Page 4 of this instruction manual.
14. See Operation of Controls procedures on Page 23.

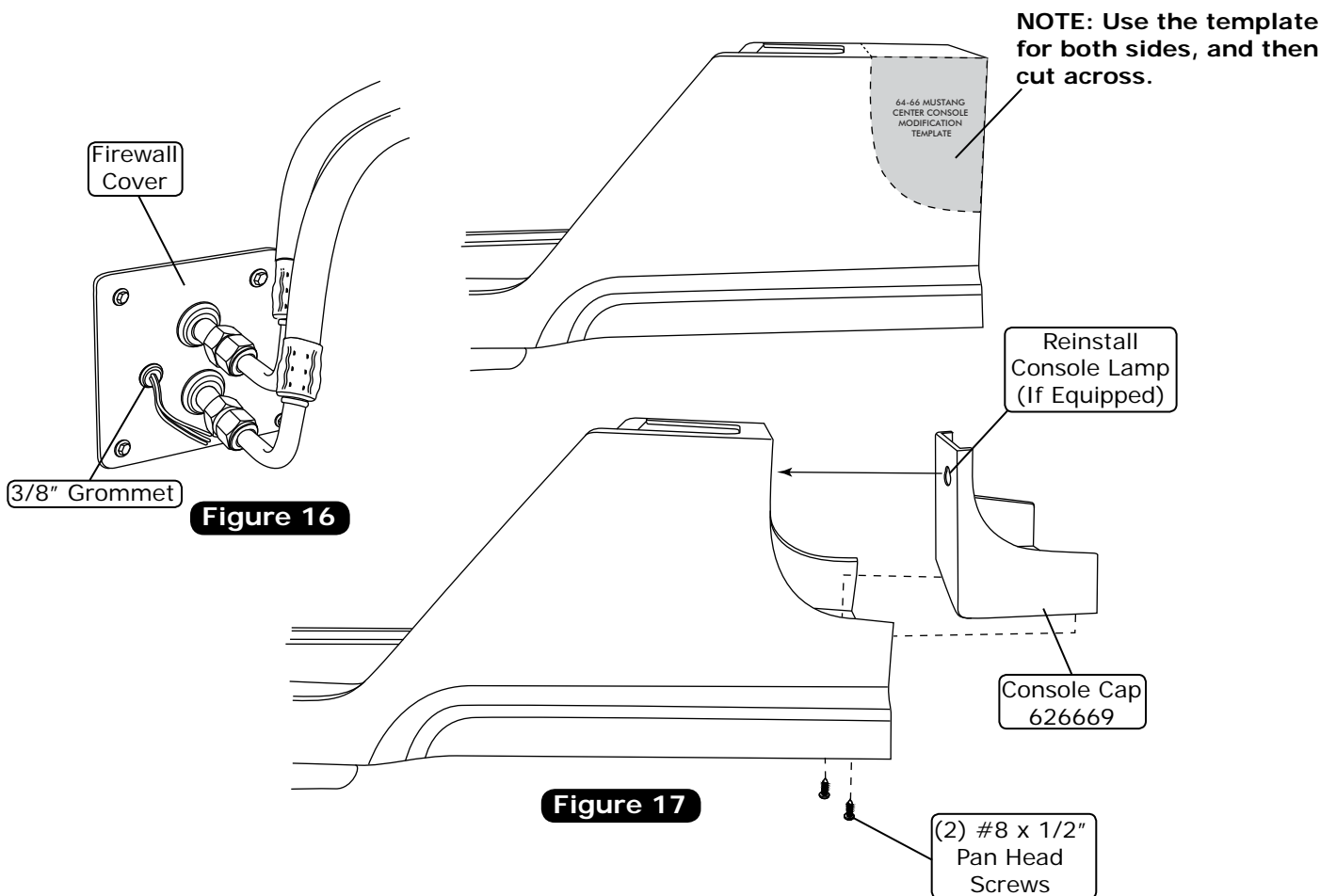



www.vintageair.com

Control Panel & Duct Hose Routing

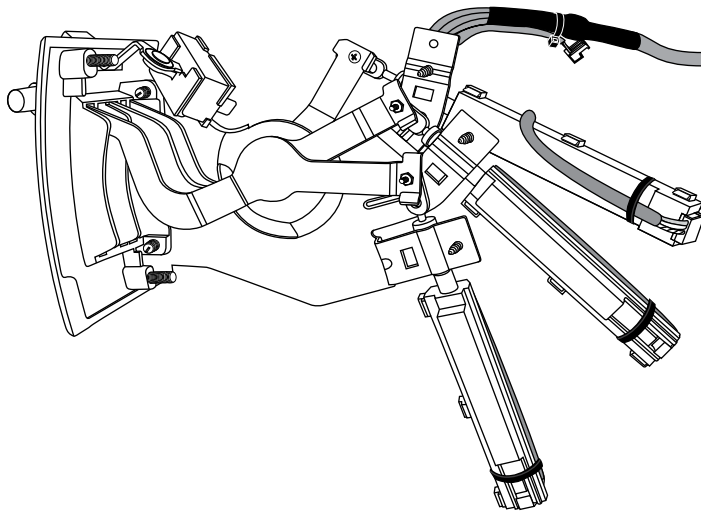

NOTE: While looking through the glove box and speaker holes, turn the wipers on and check for clearance through the full range of motion.

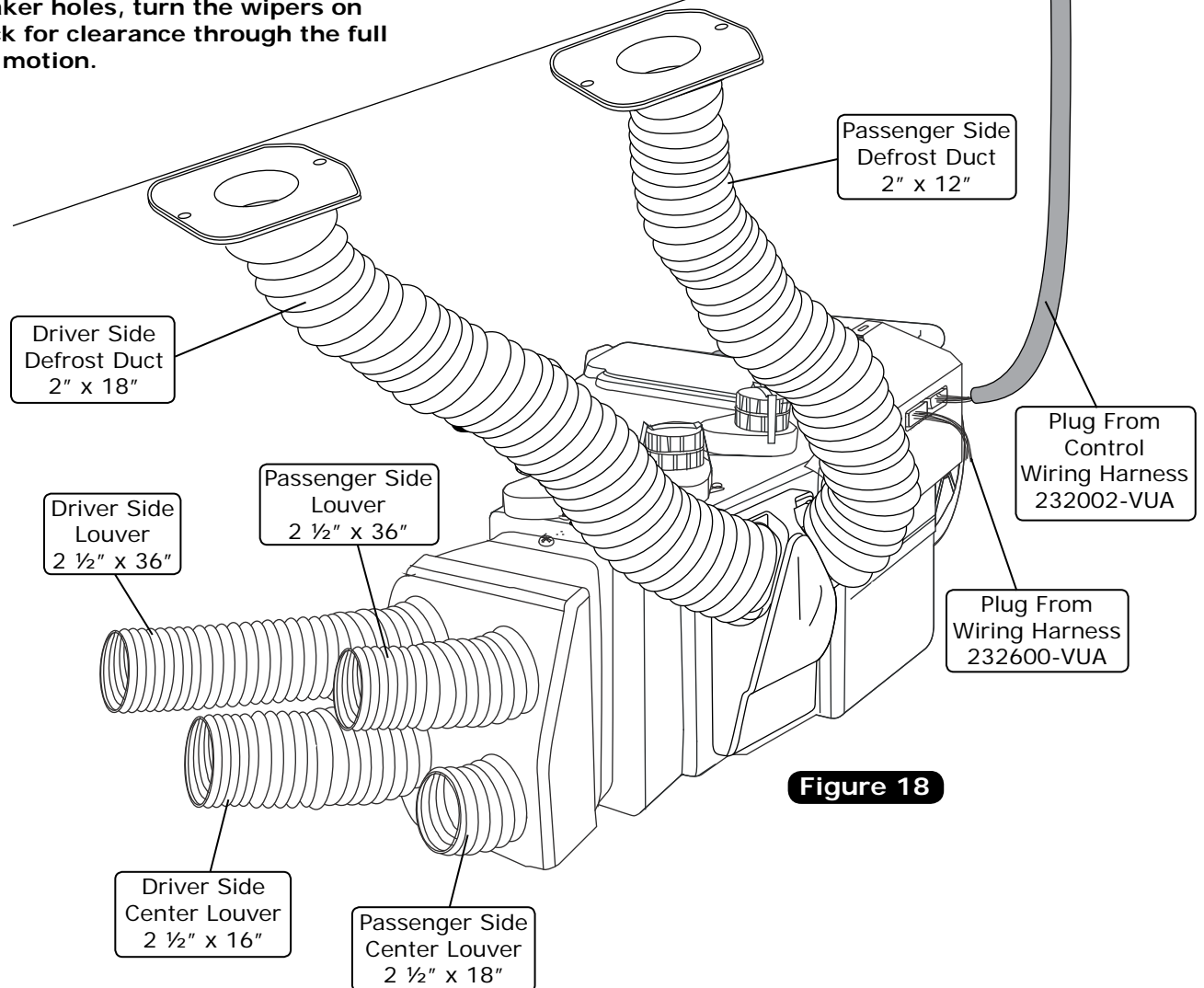

Figure 18



www.vintageair.com

Evaporator Hardline Installation

NOTE: After installing the #10 hardline, wrap all exposed metal (fittings & tubes) inside passenger compartment with the supplied press tape.

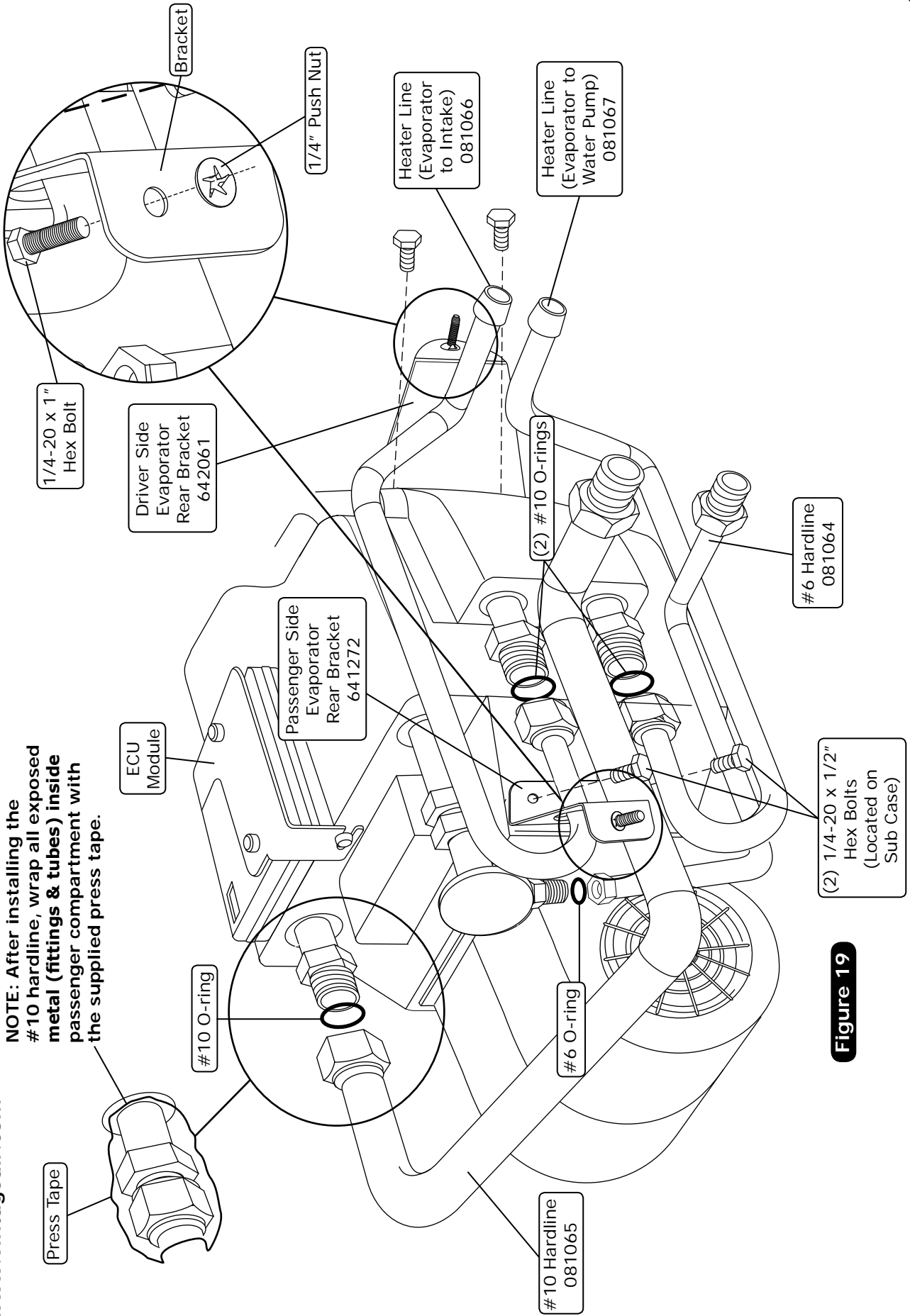

Figure 19



www.vintageair.com

Wiring Diagram

232007-VUR

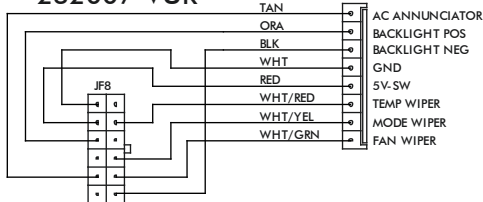

VIEWED FROM WIRE SIDE

232002-VUA

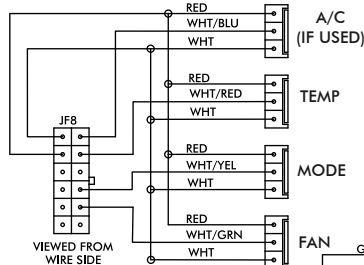

VIEWED FROM WIRE SIDE

PROGRAM

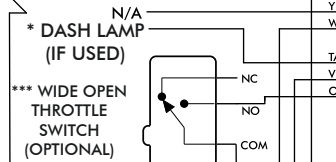

GEN IV ECU

GEN IV WIRING DIAGRAM
REV E, 10/6/2017

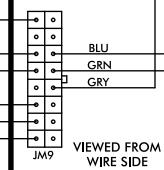

VIEWED FROM WIRE SIDE

PRE-WIRED

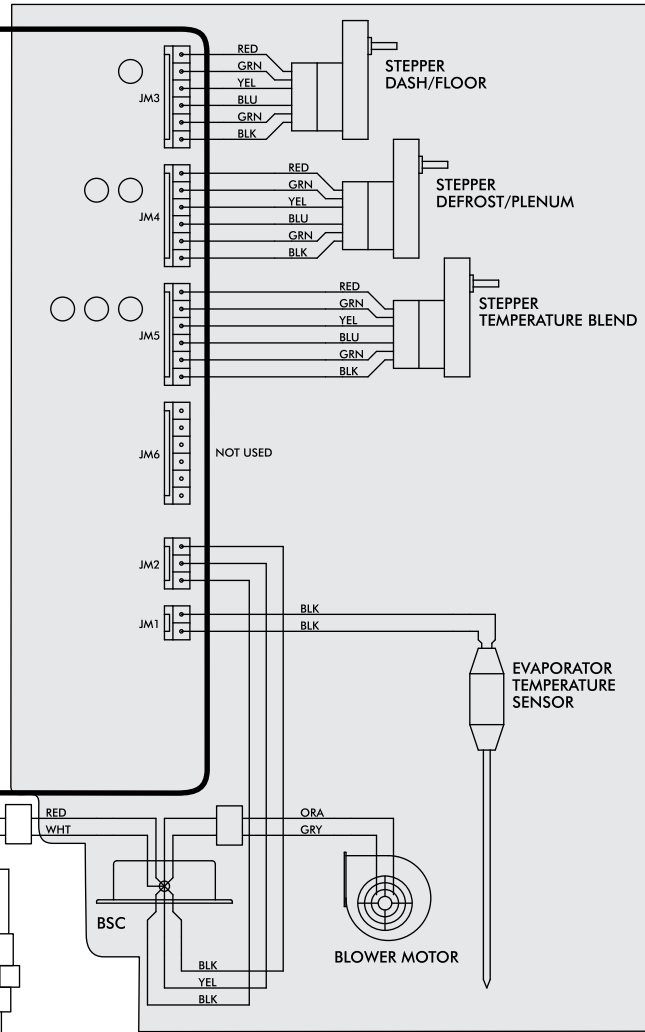

NOTE: = CHASSIS GROUND

* Dash lamp is used only with type 232007-VUR harness.

** Warning: Always mount circuit breaker as close to the battery as possible. (NOTE: Wire between battery and circuit breaker is unprotected and should be carefully routed to avoid a short circuit).

*** Wide open throttle switch contacts close only at full throttle, which disables A/C



www.vintageair.com

Gen IV Wiring Connection Instruction

WIRING HARNESS

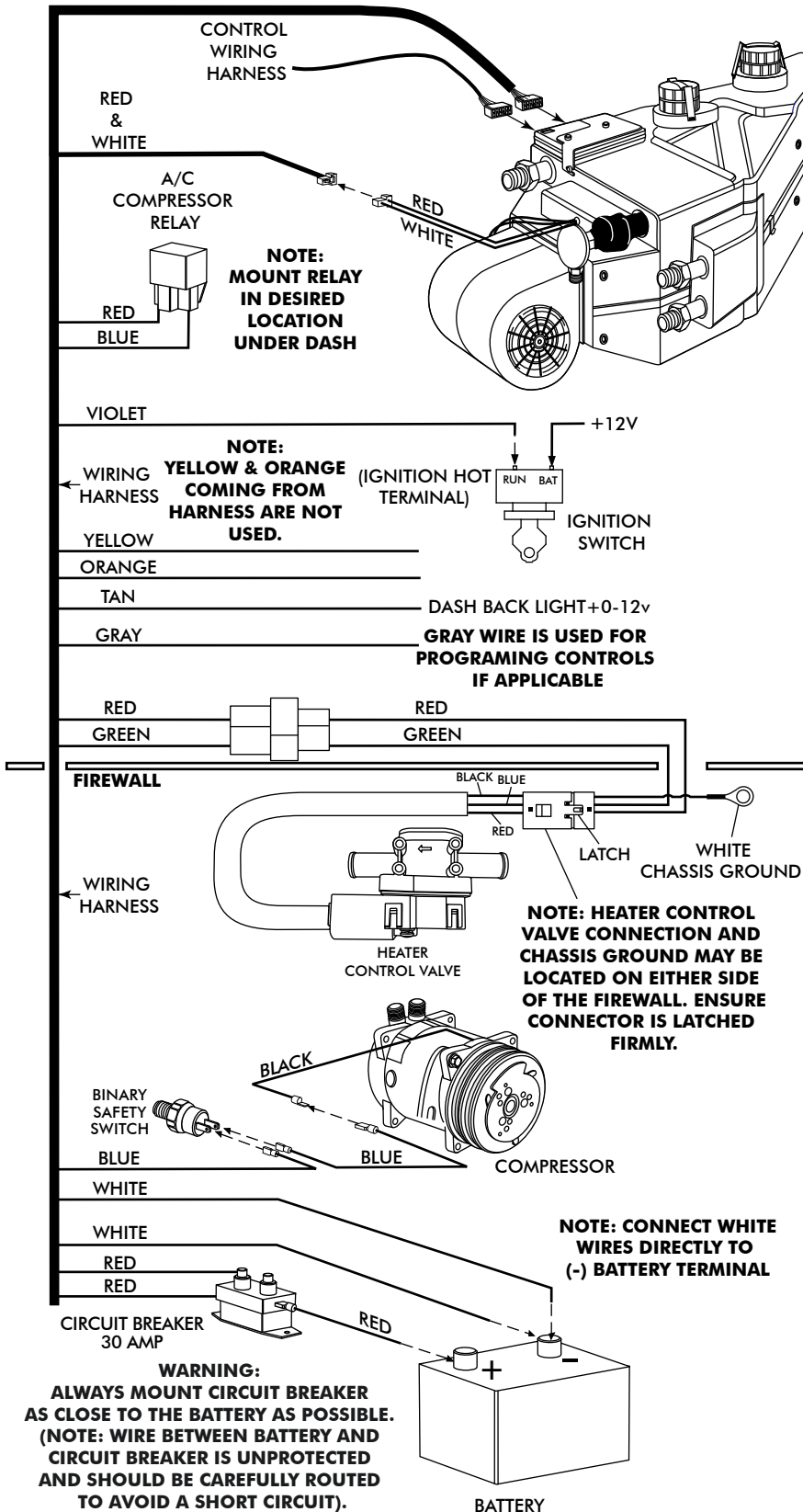

NOTE:
MOUNT RELAY
IN DESIRED
LOCATION
UNDER DASH

NOTE:
YELLOW & ORANGE
COMING FROM
HARNESS ARE NOT
USED.

**GRAY WIRE IS USED FOR
PROGRAMMING CONTROLS
IF APPLICABLE**

**NOTE: HEATER CONTROL
VALVE CONNECTION AND
CHASSIS GROUND MAY BE
LOCATED ON EITHER SIDE
OF THE FIREWALL. ENSURE
CONNECTOR IS LATCHED
FIRMLY.**

**NOTE: CONNECT WHITE
WIRES DIRECTLY TO
(-) BATTERY TERMINAL**

WARNING:
ALWAYS MOUNT CIRCUIT BREAKER
AS CLOSE TO THE BATTERY AS POSSIBLE.
(NOTE: WIRE BETWEEN BATTERY AND
CIRCUIT BREAKER IS UNPROTECTED
AND SHOULD BE CAREFULLY ROUTED
TO AVOID A SHORT CIRCUIT).

Ignition Switch:
Violet 12V ignition switch source (key on accessory) position must be switched.

Dash Light:
When using a Vintage Air-supplied control panel, connect the tan wire from the Gen IV evaporator wiring harness to the factory dash lights to enable panel backlighting.

Heater Control Valve:
Install with servo motor facing down, as shown. Note flow direction arrow molded into valve body and install accordingly.

Binary/Trinary & Compressor:
Binary: Connect as shown (typical compressor wiring). Be sure compressor body is grounded.
Trinary Switch: Connect according to trinary switch wiring diagram.

Circuit Breaker/Battery:
White **must** run to (-) battery. Red may run to (+) battery or starter. Mount circuit breaker as close to battery as possible.



www.vintageair.com

Operation of Controls

On Gen IV systems with three lever/knob controls, the temperature control toggles between heat and A/C operations. To activate A/C, move the temperature lever/knob all the way to cold and then back it off to the desired vent temperature. For heat operation, move the temperature lever/knob all the way to hot and then adjust to the desired vent temperature. The blower will momentarily change speed, each time you toggle between operations, to indicate the change. **NOTE: For proper control panel function, refer to control panel instructions for calibration procedure.**

Blower Speed

This lever/knob controls blower speed, from OFF to HI.

Mode Control

This lever/knob controls the mode positions, from DASH to FLOOR to DEFROST, with a blend in between.

Temperature Control

This lever/knob controls the temperature, from HOT to COLD.

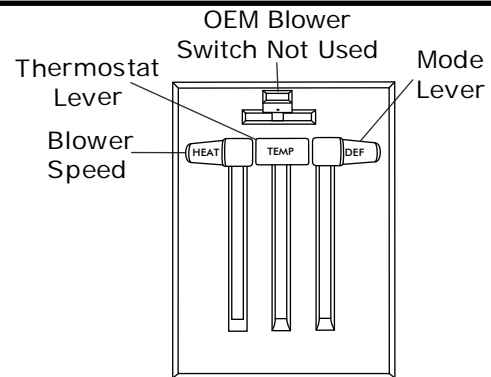

A/C Operation

Blower Speed

Adjust to desired speed.

Mode Control

Adjust to desired mode position (DASH position recommended).

Temperature Control

For A/C operation, adjust to coldest position to engage compressor (Adjust between HOT and COLD to reach desired temperature).

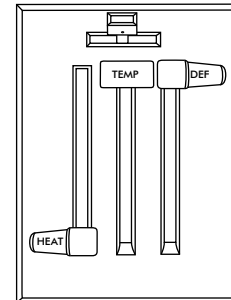

Heat Operation

Blower Speed

Adjust to desired speed.

Mode Control

Adjust to desired mode position (FLOOR position recommended).

Temperature Control

For maximum heating, adjust to hottest position (Adjust between HOT and COLD to reach desired temperature).

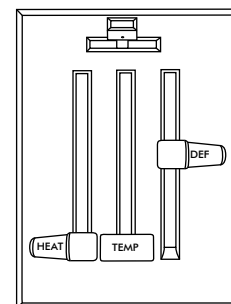

Defrost/De-fog Operation

Blower Speed

Adjust to desired speed.

Temperature Control

Adjust to desired temperature.

Mode Control

Adjust to DEFROST position for maximum defrost, or between FLOOR and DEFROST positions for a bi-level blend (Compressor is automatically engaged).

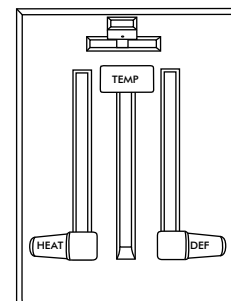



www.vintageair.com

Troubleshooting Guide

Symptom	Condition	Checks	Actions	Notes
1a. Blower stays on high speed when ignition is on.	No other functions work.	Check for damaged pins or wires in control head plug.	Verify that all pins are inserted into plug. Ensure that no pins are bent or damaged in ECU.	Loss of ground on this wire renders control head inoperable.
	All other functions work.	Check for damaged ground wire (white) in control head harness.	Verify continuity to chassis ground with white control head wire at various points.	
		Check for damaged blower switch or potentiometer and associated wiring.	See blower switch check procedure.	
1b. Blower stays on high speed when ignition is on or off.		Unplug 3-wire BSC control connector from ECU. If blower shuts off, ECU is either improperly wired or damaged.	Be sure the small, 20 GA white ground wire is connected to the battery ground post. If it is, replace the ECU.	No other part replacements should be necessary.
		Unplug 3-wire BSC control connector from ECU. If blower stays running, BSC is either improperly wired or damaged.	Check to ensure that no BSC wiring is damaged or shorted to vehicle ground. The BSC operates the blower by ground side pulse width modulation switching. The positive wire to the blower will always be hot. If the "ground" side of the blower is shorted to chassis ground, the blower will run on HI.	
		Replace BSC (This will require removal of evaporator from vehicle).		
2. Compressor will not turn on (All other functions work).	System is not charged.	System must be charged for compressor to engage.	Charge system or bypass pressure switch.	Danger: Never bypass safety switch with engine running. Serious injury can result.
		Check for faulty A/C potentiometer or associated wiring (not applicable to 3-pot controls).	Check continuity to ground on white control head wire. Check for 5V on red control head wire.	
	System is charged.	Check for disconnected or faulty thermistor.	Check 2-pin connector at ECU housing.	Disconnected or faulty thermistor will cause compressor to be disabled.
3. Compressor will not turn off (All other functions work).		Check for faulty A/C potentiometer or associated wiring.	Repair or replace pot/control wiring.	Red wire at A/C pot should have approximately 5V with ignition on. White wire will have continuity to chassis ground. White/Blue wire should vary between 0V and 5V when lever is moved up or down.
		Check for faulty A/C relay.	Replace relay.	



www.vintageair.com

Troubleshooting Guide (Cont.)

Symptom	Condition	Checks	Actions	Notes
4.	Works when engine is not running; shuts off when engine is started (typically early Gen IV, but possible on all versions).	Noise interference from either ignition or alternator.	Install capacitors on ignition coil and alternator. Ensure good ground at all points. Relocate coil and associated wiring away from ECU and ECU wiring. Check for burned or loose plug wires.	Ignition noise (radiated or conducted) will cause the system to shut down due to high voltage spikes. If this is suspected, check with a quality oscilloscope. Spikes greater than 16V will shut down the ECU. Install a radio capacitor at the positive post of the ignition coil (see radio capacitor installation bulletin). A faulty alternator or worn out battery can also result in this condition.
	System will not turn on, or runs intermittently.	Will not turn on under any conditions.	Check for positive power at heater valve green wire and blower red wire. Check for ground on control head white wire.	
		Verify battery voltage is greater than 10 volts and less than 16.	Verify proper meter function by checking the condition of a known good battery.	
5.	No mode change at all.	Check for damaged mode switch or potentiometer and associated wiring.		Typically caused by evaporator housing installed in a bind in the vehicle. Be sure all mounting locations line up and don't have to be forced into position.
	Partial function of mode doors.	Check for obstructed or binding mode doors.		
		Check for damaged stepper motor or wiring.		
6.	Battery voltage is at least 12V.	Check for at least 12V at circuit breaker.	Ensure all system grounds and power connections are clean and tight.	System shuts off blower at 10V. Poor connections or weak battery can cause shutdown at up to 11V.
	Blower turns on and off rapidly.	Battery voltage is less than 12V.	Charge battery.	
7.	Erratic functions of blower, mode, temp, etc.	Check for damaged switch or pot and associated wiring.	Repair or replace.	
8.	When ignition is turned on, blower momentarily comes on, then shuts off. This occurs with the blower switch in the OFF position.	This is an indicator that the system has been reset. Be sure the red power wire is on the battery post, and not on a switched source. Also, if the system is pulled below 7V for even a split second, the system will reset.	Run red power wire directly to battery.	



www.vintageair.com

Passenger Side Evaporator Rear Bracket Template

NOTE: Due to printing variances, measure the line below before using this template.
If template is scaled properly, the line should measure 6 inches.

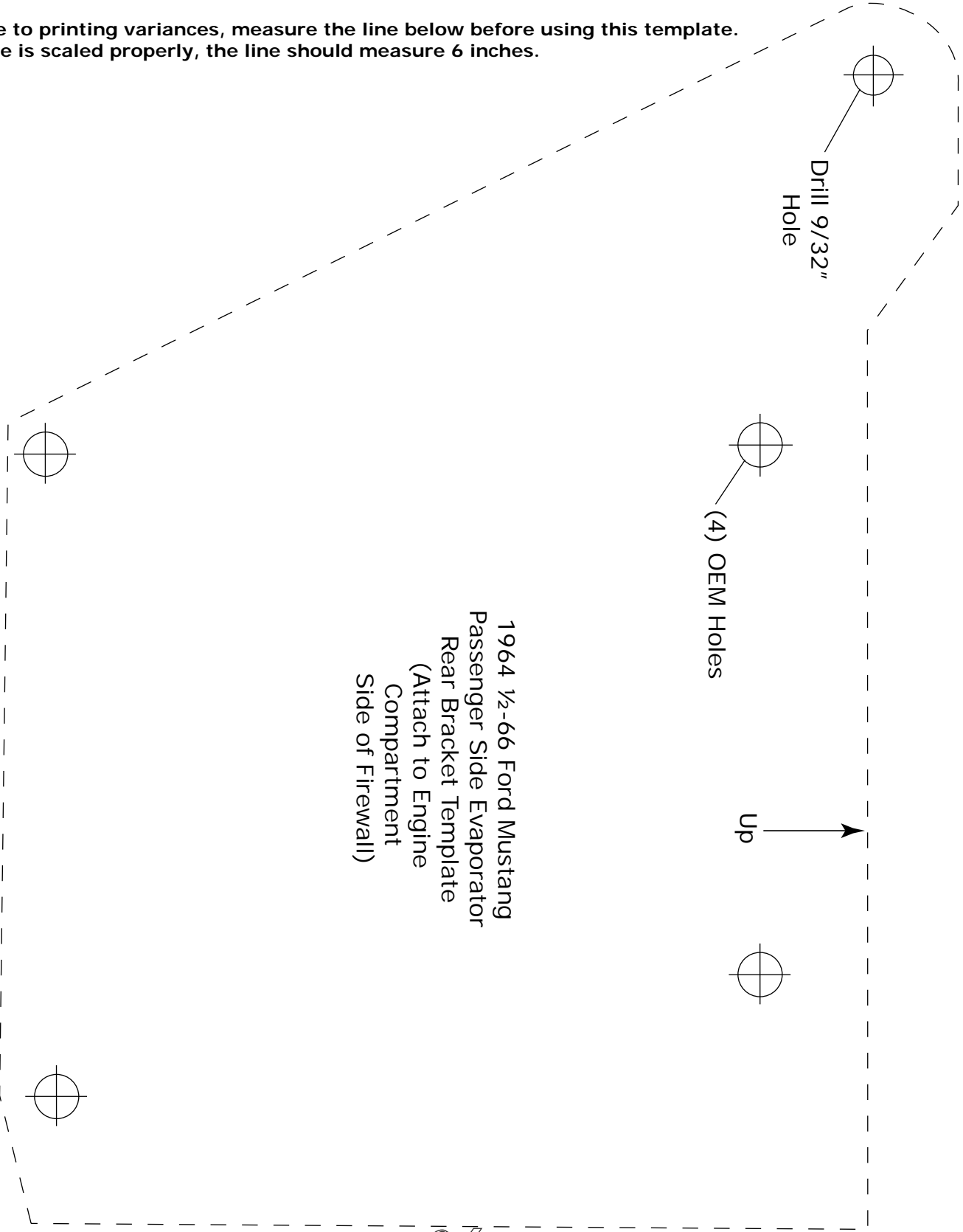

1964 1/2-66 Ford Mustang
Passenger Side Evaporator
Rear Bracket Template
(Attach to Engine
Compartment
Side of Firewall)

Cut Along
Dotted Line 



www.vintageair.com

Driver Side Evaporator Rear Bracket Template

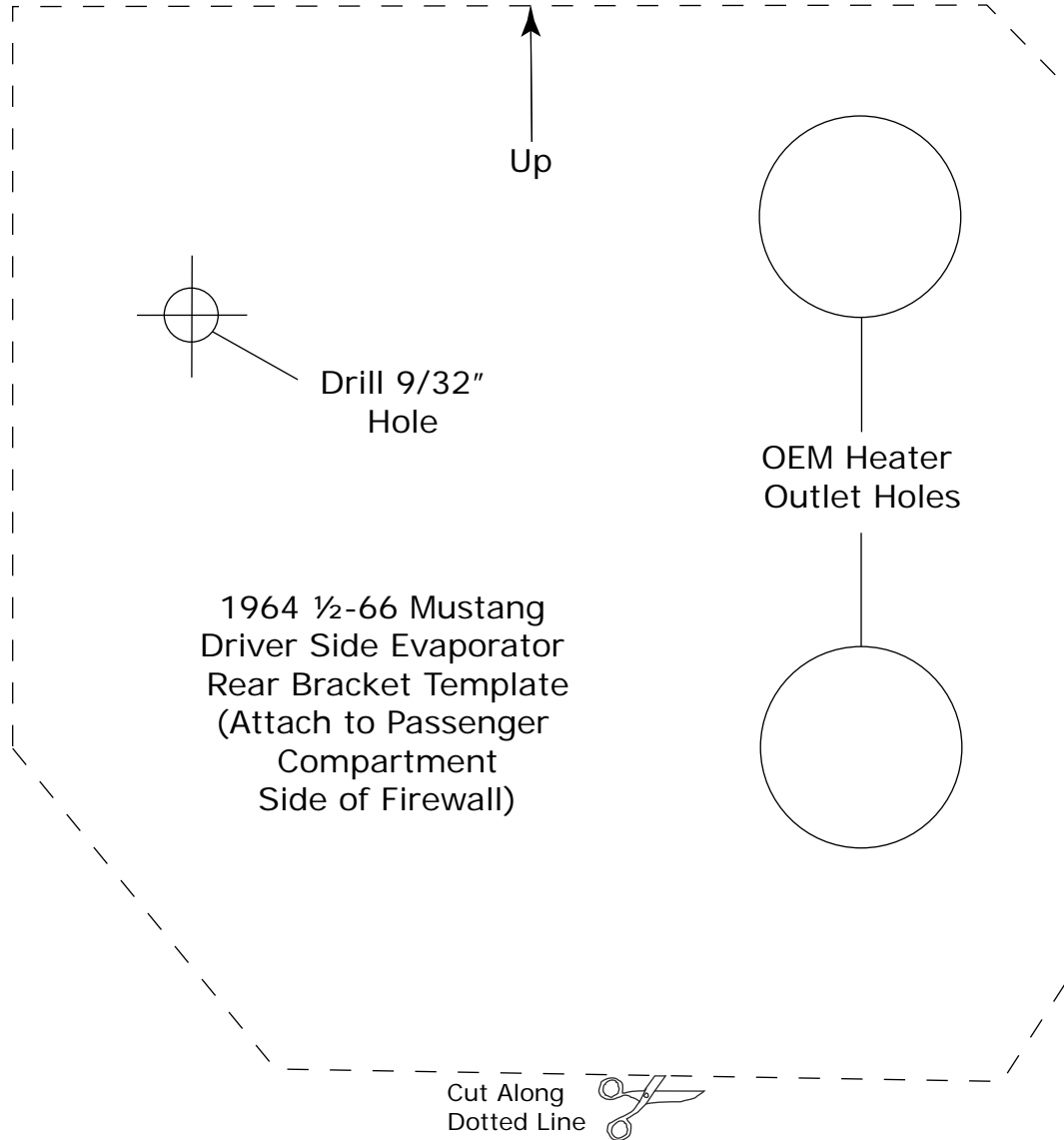

1964 1/2-66 Mustang
 Driver Side Evaporator
 Rear Bracket Template
 (Attach to Passenger
 Compartment
 Side of Firewall)

NOTE: Due to printing variances, measure the line below before using this template. If template is scaled properly, the line should measure 6 inches.

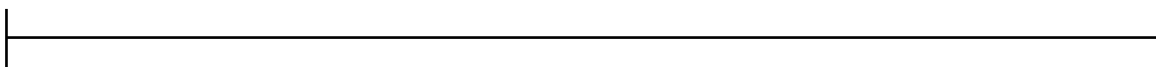



www.vintageair.com

Center Console Modification Template

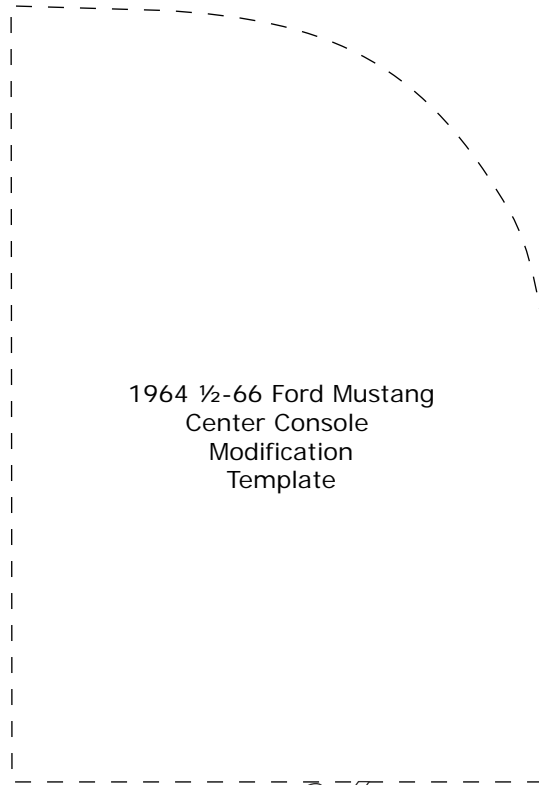

1964 1/2-66 Ford Mustang
Center Console
Modification
Template

Cut Along
Dotted Line 

NOTE: Due to printing variances, measure the line below before using this template. If template is scaled properly, the line should measure 6 inches.

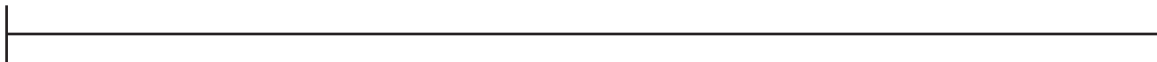



Packing List: Evaporator Kit (554164)

No.	Qty.	Part No.	Description
1.	1	744004-VUE	Gen IV 4-Vent Evaporator Sub Case
2.	1	781066	Accessory Kit

Checked By: _____
 Packed By: _____
 Date: _____

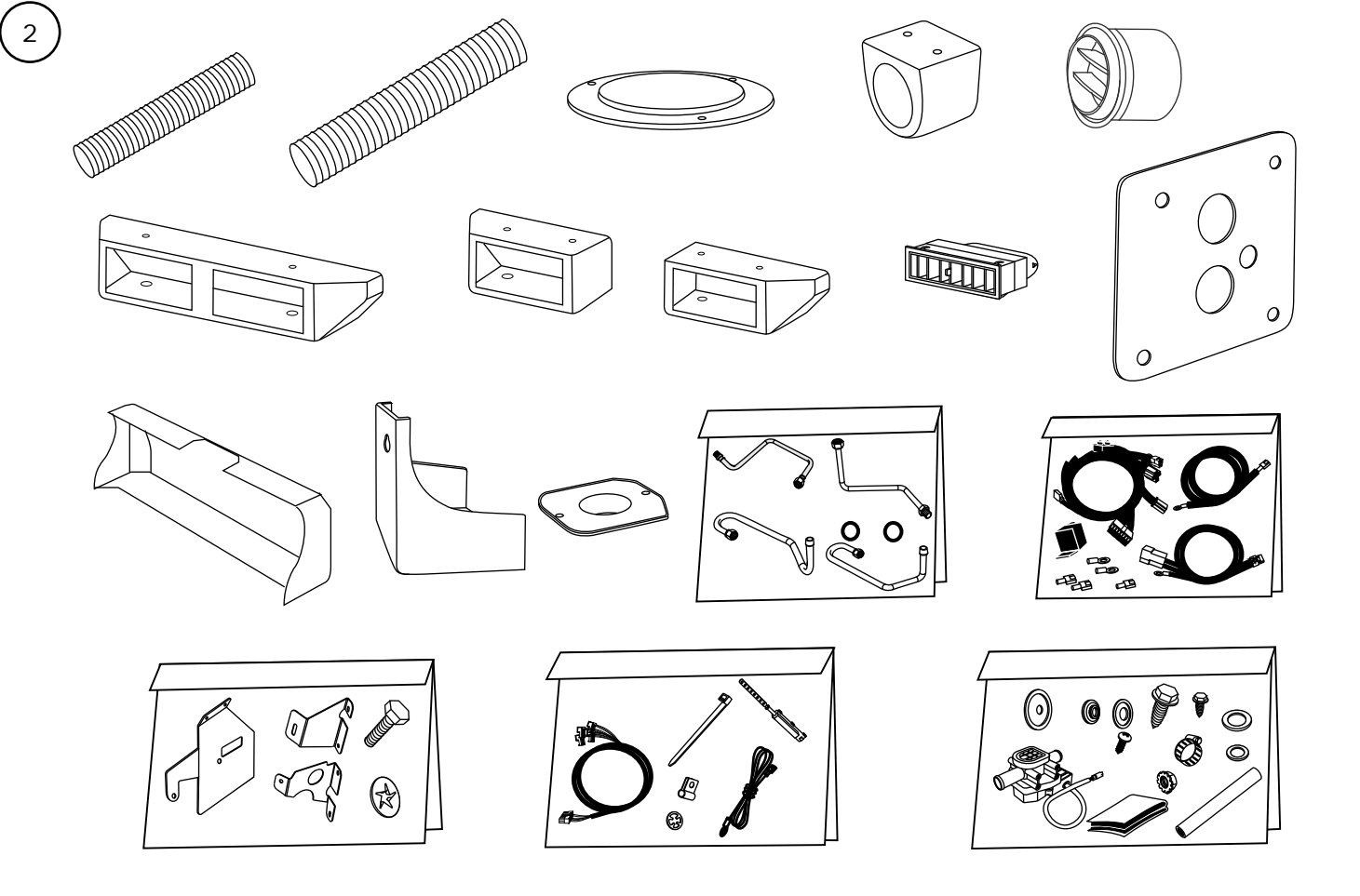
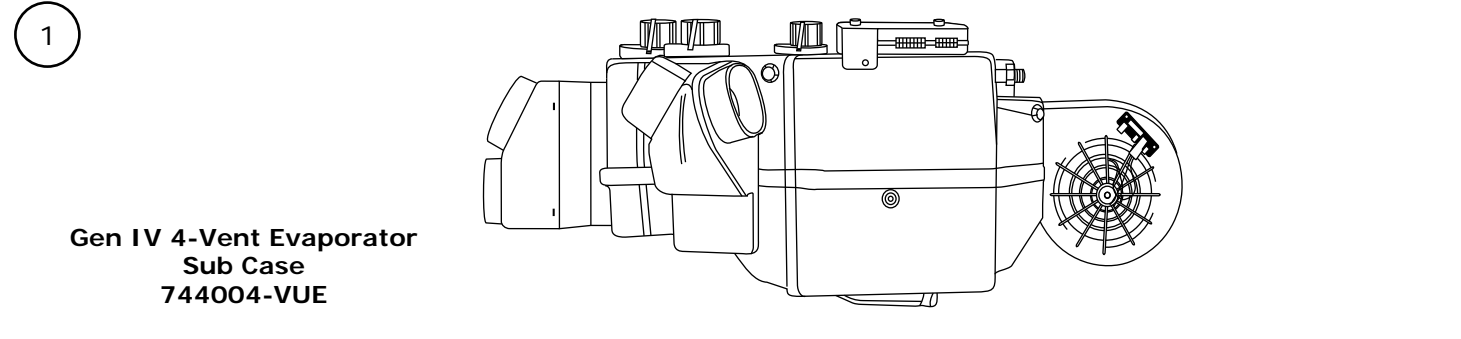

Accessory Kit
781066

**NOTE: Images may not depict actual parts and quantities.
Refer to packing list for actual parts and quantities.**