

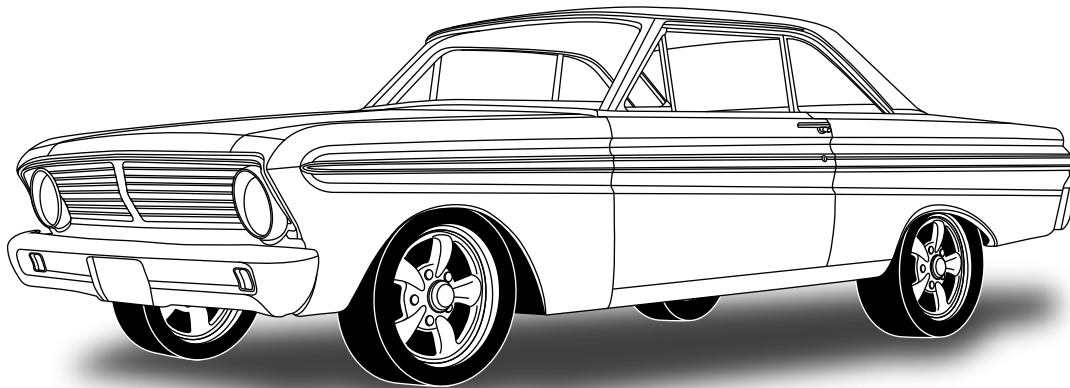

an ISO 9001:2008 Registered Company

1964-65 Ford Falcon, Ranchero

Evaporator Kit
(554150)



18865 Goll St. San Antonio, TX 78266
Phone: 210-654-7171
Fax: 210-654-3113
www.vintageair.com



www.vintageair.com

Table of Contents

Thank you for purchasing this evaporator kit from Vintage Air. When installing these components as part of a complete SureFit™ system, Vintage Air recommends working from front to back on the vehicle, installing the condenser kit, hose kit, and compressor first, followed by the wiring, evaporator, and finally the control panel.

Cover.....	1
Table of Contents.....	2
Packing List/Parts Disclaimer.....	3
Information Page.....	4
Wiring Notice.....	5
Engine Compartment Disassembly, Condenser Assembly and Installation, Compressor and Brackets, Pulleys.....	6
Passenger Compartment Disassembly.....	7
Defrost Duct Installation, Fresh Air Cap Installation.....	8
Evaporator Bracket, Evaporator Hardline & Heater Hose Fitting Installation.....	9
Passenger Side Firewall Modification, Driver Side Firewall Modification.....	10
Firewall Cover Installation.....	11
Evaporator Installation.....	12
Drain Hose Installation, Lubricating O-rings, A/C Hose Installation.....	13
Heater Hose & Heater Control Valve Installation.....	14
A/C and Heater Hose Routing.....	15
Center Louver Installation.....	16
Driver and Passenger Side Under Dash Louver Installation.....	17
Final Steps.....	18
Control Panel & Duct Hose Routing.....	19
Wiring Diagram.....	20
Gen IV Wiring Connection Instruction.....	21
Operation of Controls.....	22
Troubleshooting Guide.....	23
Troubleshooting Guide (Cont.).....	24
Passenger Side Evaporator Rear Bracket Template.....	25
Driver Side Evaporator Rear Bracket Template.....	26
Packing List.....	27



www.vintageair.com

Packing List: Evaporator Kit (554150)

No.	Qty.	Part No.	Description
1.	1	744014	Gen IV Evaporator Sub Case, 45° 4-vent with 204 ECU
2.	1	784150	Accessory Kit

**** Before beginning installation, open all packages and check contents of shipment. Please report any shortages directly to Vintage Air within 15 days. After 15 days, Vintage Air will not be responsible for missing or damaged items.**

1

Gen IV Evaporator
Sub Case
45° 4-vent with 204 ECU
744014

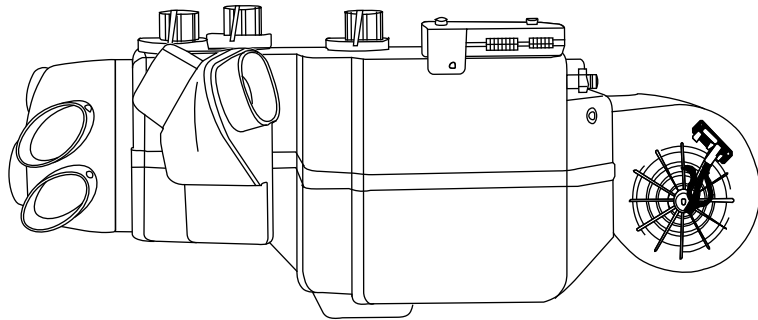

2

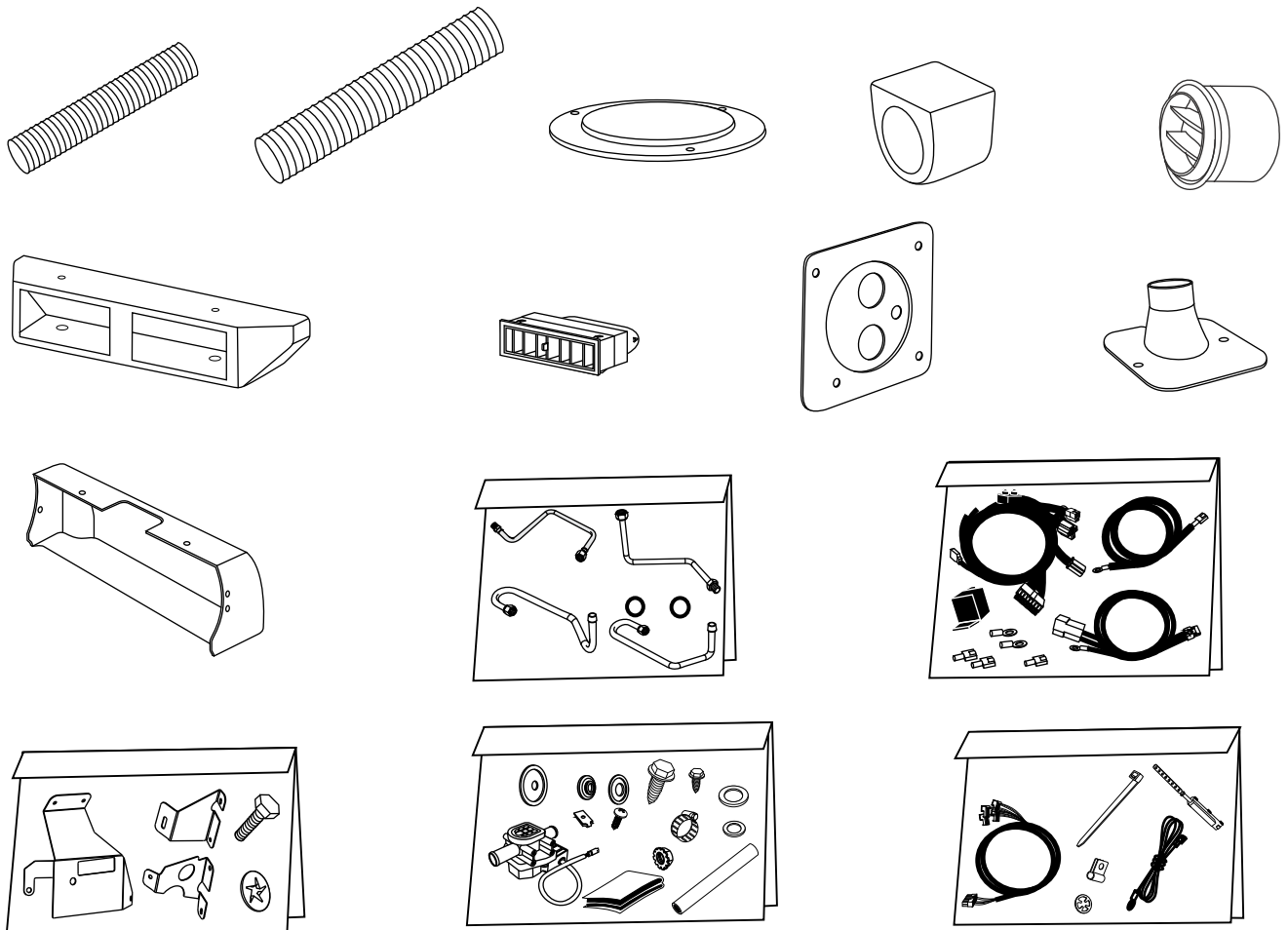

Accessory Kit
784150

NOTE: Images may not depict actual parts and quantities. Refer to packing list for actual parts and quantities.



www.vintageair.com

Important Notice—Please Read

For Maximum System Performance, Vintage Air Recommends the Following:

NOTE: Vintage Air systems are designed to operate with R134a refrigerant only. Use of any other refrigerant could damage your A/C system and/or vehicle, and possibly cause a fire, in addition to potentially voiding the warranties of the A/C system and its components.

Refrigerant Capacities:

Vintage Air System: 1.8 lbs. (28.8 oz.) or 816 grams of **R134a**, charged by weight with a quality charging station or scale. **NOTE: Use of the proper type and amount of refrigerant is critical to system operation and performance.**

Other Systems: Consult manufacturer's guidelines.

Lubricant Capacities:

New Vintage Air-Supplied Sanden Compressor: No additional oil needed (Compressor is shipped with proper oil charge).

All Other Compressors: Consult manufacturer (Some compressors are shipped dry and will need oil added).

Safety Switches

Your Vintage Air system is equipped with a binary pressure safety switch. A binary switch disengages the compressor clutch in cases of extreme low pressure conditions (refrigerant loss) or excessively high head pressure (406 PSI) to prevent compressor damage or hose rupture. A trinary switch combines Hi/Lo pressure protection with an electric fan operation signal at 254 PSI, and should be substituted for use with electric fans. Compressor safety switches are extremely important since an A/C system relies on refrigerant to circulate lubricant.

Service Info:

Protect Your Investment: Prior to assembly, it is critical that the compressor, evaporator, A/C hoses and fittings, hardlines, condenser and receiver/drier remain capped. Removing caps prior to assembly will allow moisture, insects and debris into the components, possibly leading to reduced performance and/or premature failure of your A/C system. This is especially important with the receiver/drier.

Additionally, when caps are removed for assembly, **BE CAREFUL!** Some components are shipped under pressure with dry nitrogen.

Evacuate the System for 35-45 Minutes: Ensure that system components (Drier, compressor, evaporator and condenser) are at a temperature of at least 85°F. On a cool day, the components can be heated with a heat gun **or** by running the engine with the heater on before evacuating. Leak check and charge to specifications.

Bolts Passing Through Cowl and/or Firewall:

To ensure a watertight seal between the passenger compartment and the vehicle exterior, for all bolts passing through the cowl and/or firewall, Vintage Air recommends coating the threads with silicone prior to installation.

Heater Hose (not included with this kit):

Heater hose may be purchased from Vintage Air (Part#31800-VUD) or your local parts retailer. Routing and required length will vary based on installer preference.



www.vintageair.com

Important Wiring Notice—Please Read

Some vehicles may have had some or all of their radio interference capacitors removed. There should be a capacitor found at each of the following locations:

- 1. On the positive terminal of the ignition coil.**
- 2. If there is a generator, on the armature terminal of the generator.**
- 3. If there is a generator, on the battery terminal of the voltage regulator.**

Most alternators have a capacitor installed internally to eliminate what is called “whining” as the engine is revved. If whining is heard in the radio, or just to be extra cautious, a radio interference capacitor can be added to the battery terminal of the alternator.

It is also important that the battery lead is in good shape and that the ground leads are not compromised. There should be a heavy ground from the battery to the engine block, and additional grounds to the body and chassis.

If these precautions are not observed, it is possible for voltage spikes to be present on the battery leads. These spikes come from ignition systems and charging systems, and from switching some of the vehicle’s other systems on and off. Modern computer-operated equipment can be sensitive to voltage spikes on the power leads, which can cause unexpected resets, strange behavior and/or permanent damage.

Vintage Air strives to harden our products against these types of electrical noise, but there is a point where a vehicle’s electrical system can be degraded so much that nothing can help.

Radio interference capacitors should be available at most auto and truck parts suppliers. They typically are cylindrical in shape, a little over an inch long and a little over a half-inch in diameter, and they have a single lead coming from one end of the cylinder with a terminal on the end of the wire, as well as a mounting clip which is screwed into a good ground on the vehicle. The specific value of the capacitance is not too significant in comparison to ignition capacitors that are matched with the coil to reduce pitting of the points.

- Care must be taken, when installing the compressor lead, not to short it to ground. The compressor lead must not be connected to a condenser fan or to any other auxiliary device. Shorting to ground or connecting to a condenser fan or any other auxiliary device may damage wiring or the compressor relay, and/or cause a malfunction.
- When installing ground leads on Gen IV systems, the blower control ground and ECU ground must be connected directly to the negative battery post.
- For proper system operation, the heater control valve must be connected to the ECU.



www.vintageair.com

Engine Compartment Disassembly

NOTE: Before starting the installation, check the function of the vehicle (horn, lights, etc.) for proper operation, and study the instructions, illustrations, & diagrams.

Perform the Following:

1. Disconnect battery.
2. Remove battery (retain) (See Photo 1, below).
3. Drain radiator.
4. Remove radiator, OEM fan and fan shroud (retain) (See Photo 1, below). **NOTE: If the V-belt pulley system is being used, then 2-groove pulleys will need to be installed on the water pump and crankshaft. Therefore the radiator, fan shroud, and fan will need to be removed but retained.**
5. Remove OEM heater hoses (discard) (See Photo 1, below).
6. Remove OEM blower assembly (discard) (See Photos 1 and 2, below).
7. Remove OEM heater wiring (discard).

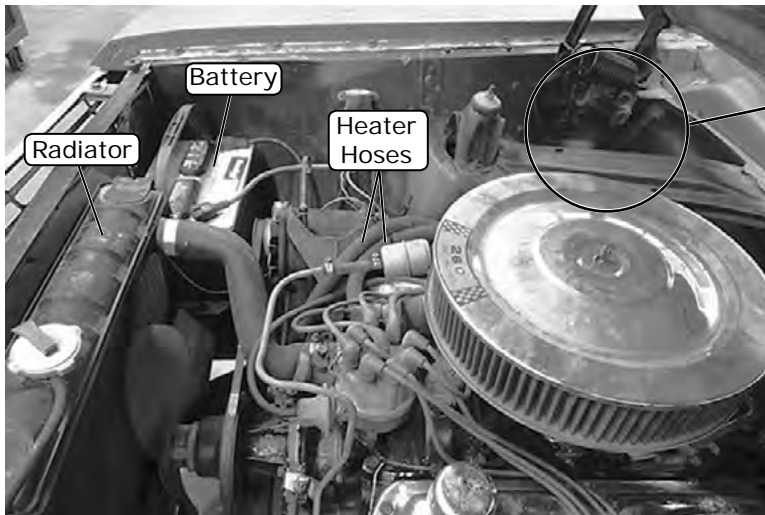

Photo 1

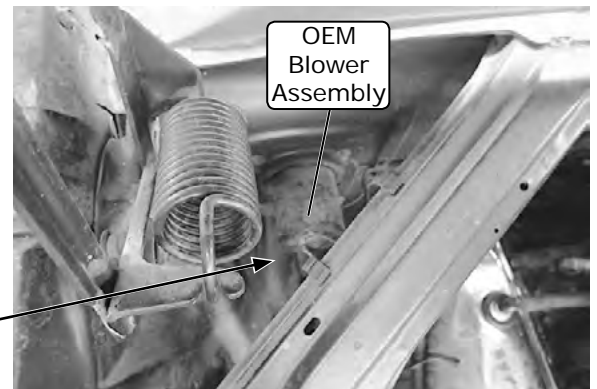

Photo 2

Condenser Assembly and Installation

1. Refer to separate instructions included with the condenser kit to install the condenser.
2. Binary switch installation (Refer to condenser instructions).

Compressor and Brackets

1. Refer to separate instructions included with the bracket kit to install the compressor bracket.

Pulleys

1. Install 2-groove pulleys (if required) on the water pump and crankshaft. **NOTE: The 2-groove V-belt pulleys are not part of the kit, but are available from Vintage Air (Part numbers 730002 and 730003). Refer to compressor bracket kit 131107 for the Small Block Ford.**



www.vintageair.com

Passenger Compartment Disassembly

Perform the Following:

1. Remove glove box door (retain) (See Figure 1, below).
2. Remove glove box (discard) (See Figure 1, below).
3. Remove under-dash A/C evaporator (if equipped) (discard) (See Figure 1, below).
4. Remove OEM heater assembly (discard) (See Figure 2, below).
5. Remove driver-side fresh air assembly with cable (discard) (See Figure 2, below).
6. Remove OEM control panel assembly & radio (retain) (See Figure 2, below).
7. Remove speaker grille (retain) (See Figure 2, below).
8. Remove OEM duct hoses from defrost ducts (discard) (See Figure 2, below).
9. Remove OEM defrost ducts (discard) (See Figure 2, below).

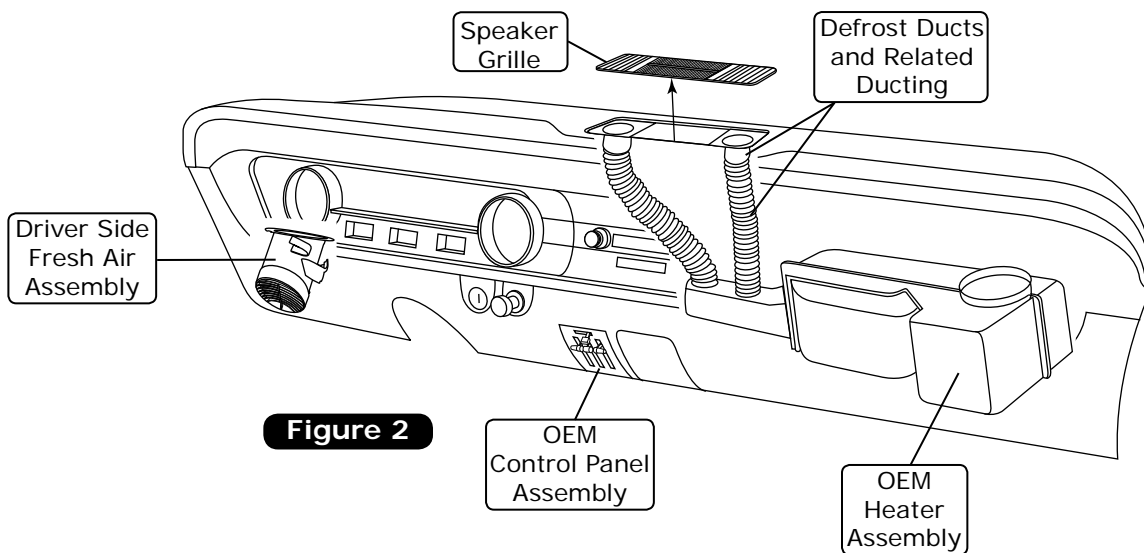
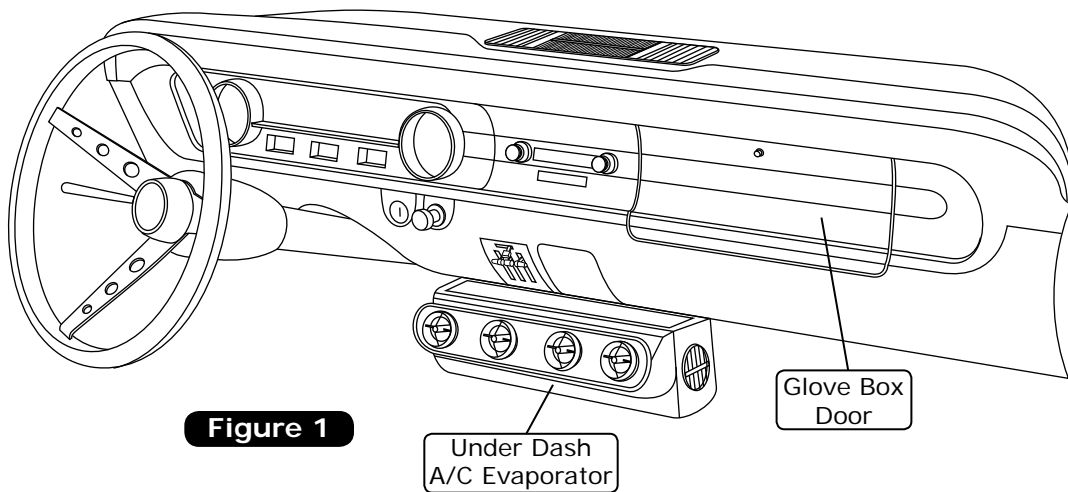



www.vintageair.com

Defrost Duct Installation

1. Install driver and passenger side defrost ducts using (4) U-nuts and (4) #8 x 1/2" pan head screws (See Figure 3, below). **NOTE: Before installing the driver side duct, attach approximately 24" of the 2" duct hose to the defrost duct. Feed the duct hose into the driver side opening on top of dash and finally attach the defrost duct.**
2. Reinstall speaker grille (See Figure 3, below).

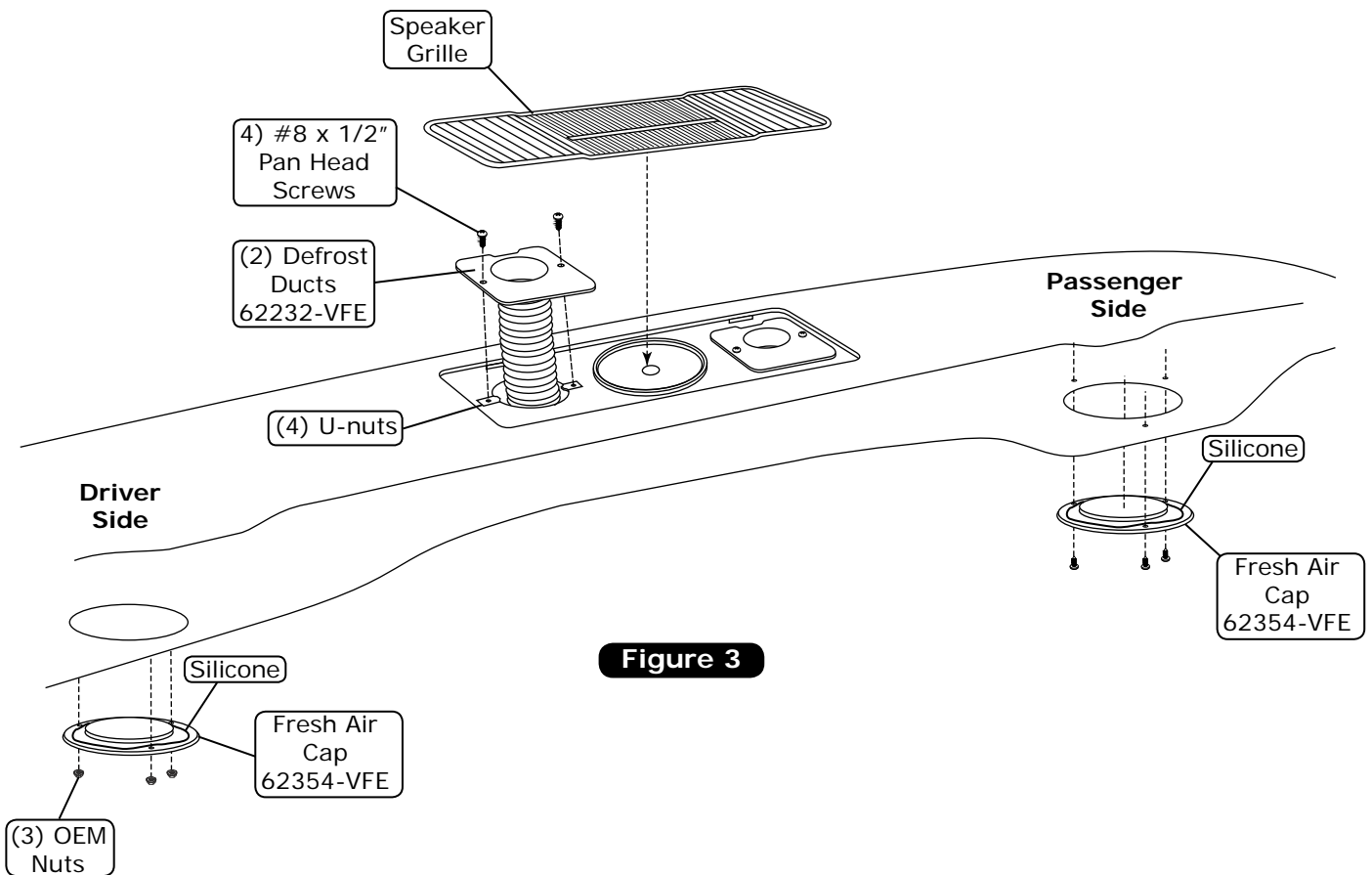

Figure 3

Fresh Air Cap Installation

Passenger Side:

1. Hold the fresh air cap under the dash and mark the (3) mounting holes as shown in Figure 3, above.
2. Drill (3) 1/8" mounting holes under the dash as shown in Figure 3, above.
3. Apply a 1/4" bead of silicone around the back side of the fresh air cap as shown in Figure 3, above.
4. Secure the fresh air cap to the fresh air hole using (3) #10 x 1/2" sheet metal screws as shown in Figure 3, above.

Driver Side:

1. Apply a 1/4" bead of silicone around the back side of the fresh air cap as shown in Figure 3, above.
2. Install the fresh air cap using OEM nuts as shown in Figure 3, above.



www.vintageair.com

Evaporator Bracket, Evaporator Hardline & Heater Hose Fitting Installation

1. On a workbench, install the evaporator rear bracket and hardlines with properly lubricated O-rings (See Figure 11, Page 13, and Figure 4, below).
2. Install the front mounting bracket onto the evaporator using (2) 1/4-20 x 1/2" hex bolts, and tighten (See Figure 5, below).

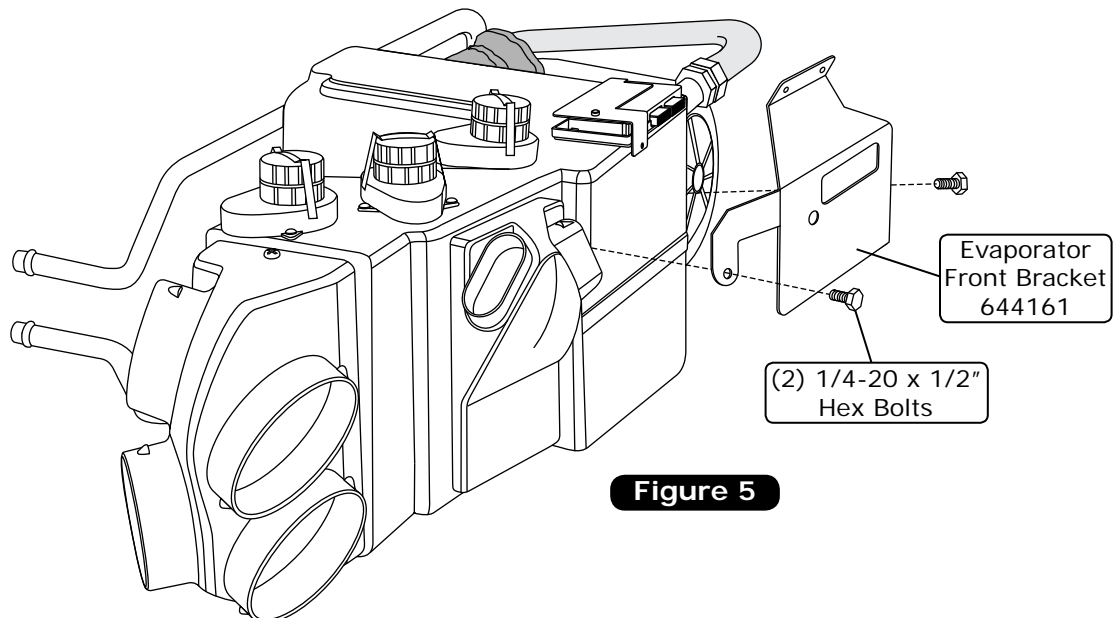
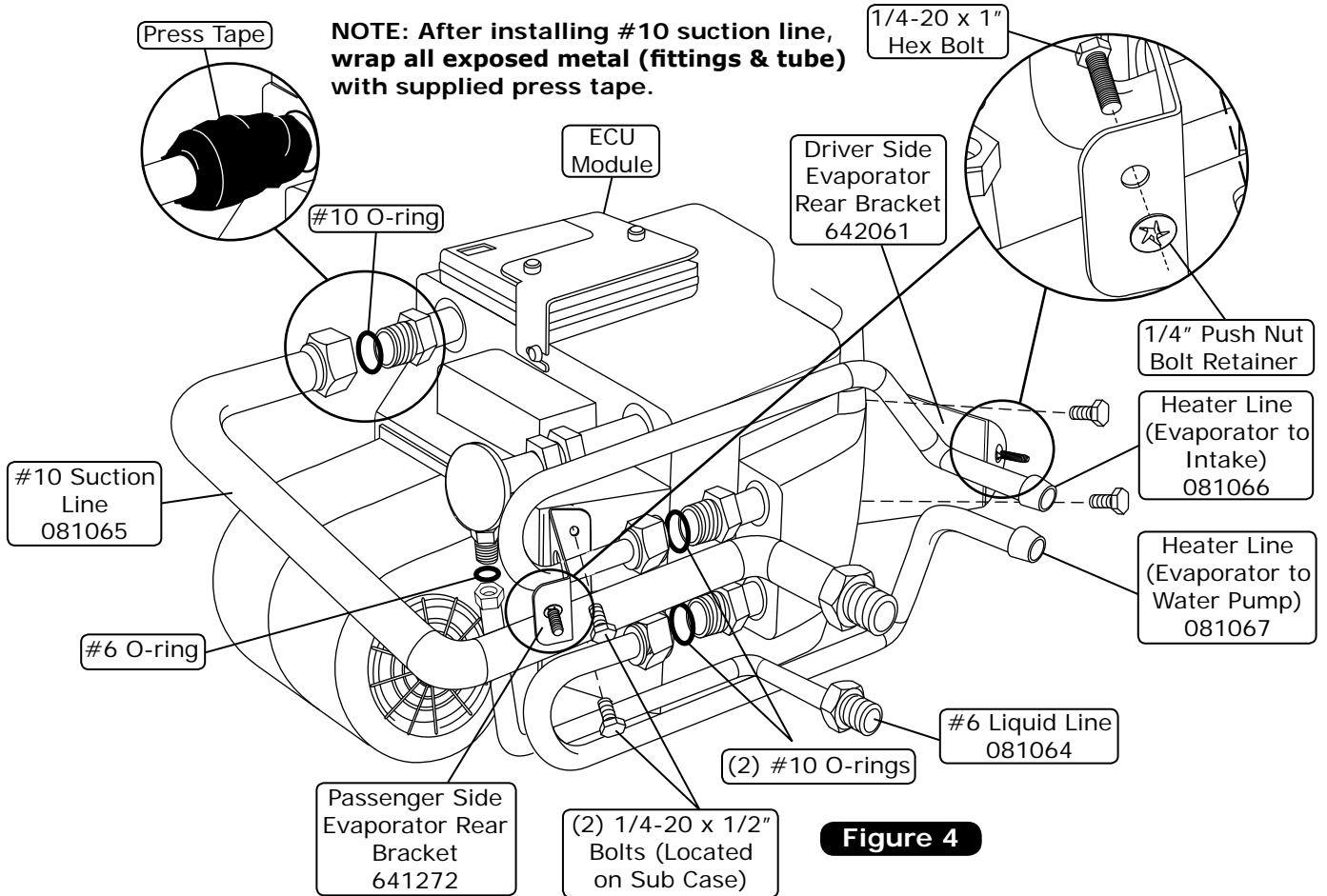



www.vintageair.com

Passenger Side Firewall Modification

1. Cut out the passenger side evaporator rear bracket template on Page 25.
2. From the engine compartment, align the template with the (4) OEM holes on the firewall, and drill a 5/16" hole as shown in Figure 6, below.

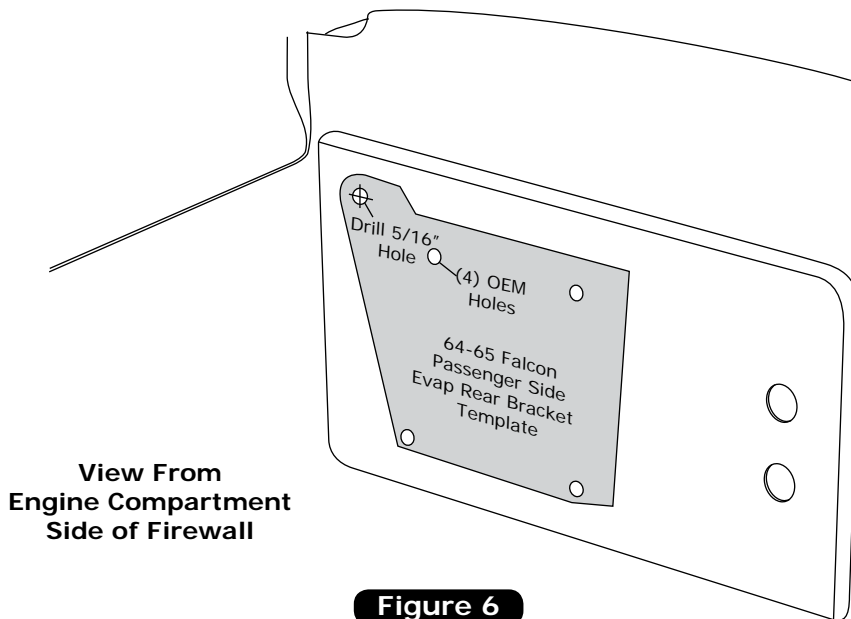

Driver Side Firewall Modification

1. From the passenger compartment, remove enough OEM insulation from the firewall to allow the evaporator and firewall cover to sit flat on the firewall.
2. Cut out the driver side evaporator rear bracket template on Page 26.
3. From the passenger compartment, align the template with the OEM heater holes on the firewall, and drill a 5/16" hole as shown in Figure 7, below.

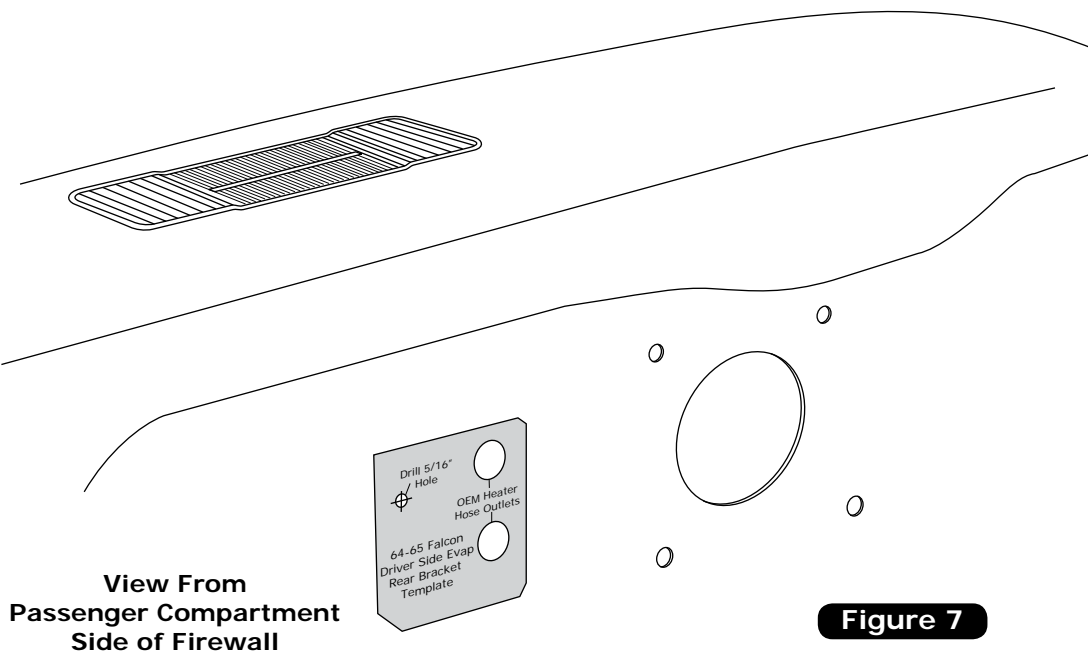



www.vintageair.com

Firewall Cover Installation

1. Apply a 1/4" bead of silicone around the back side of the firewall cover as shown in Figure 8a, below.
2. From inside the car, install the firewall cover onto the firewall. From the engine compartment, secure the firewall cover to the firewall using (4) 1/4"-20 x 3/4" hex bolts with flat washers. After installing the firewall cover, use silicone or seam sealer on the engine compartment side to seal around the blower hole (See Figure 8, below).
3. Install (2) rubber grommets into the firewall cover as shown in Figure 8, below.
4. Reinsulate around the firewall cover using 1/4" stick-on foam or thin roll-on matting.

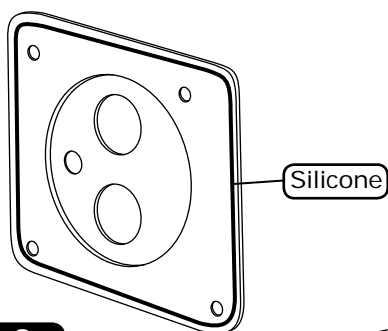

Figure 8a

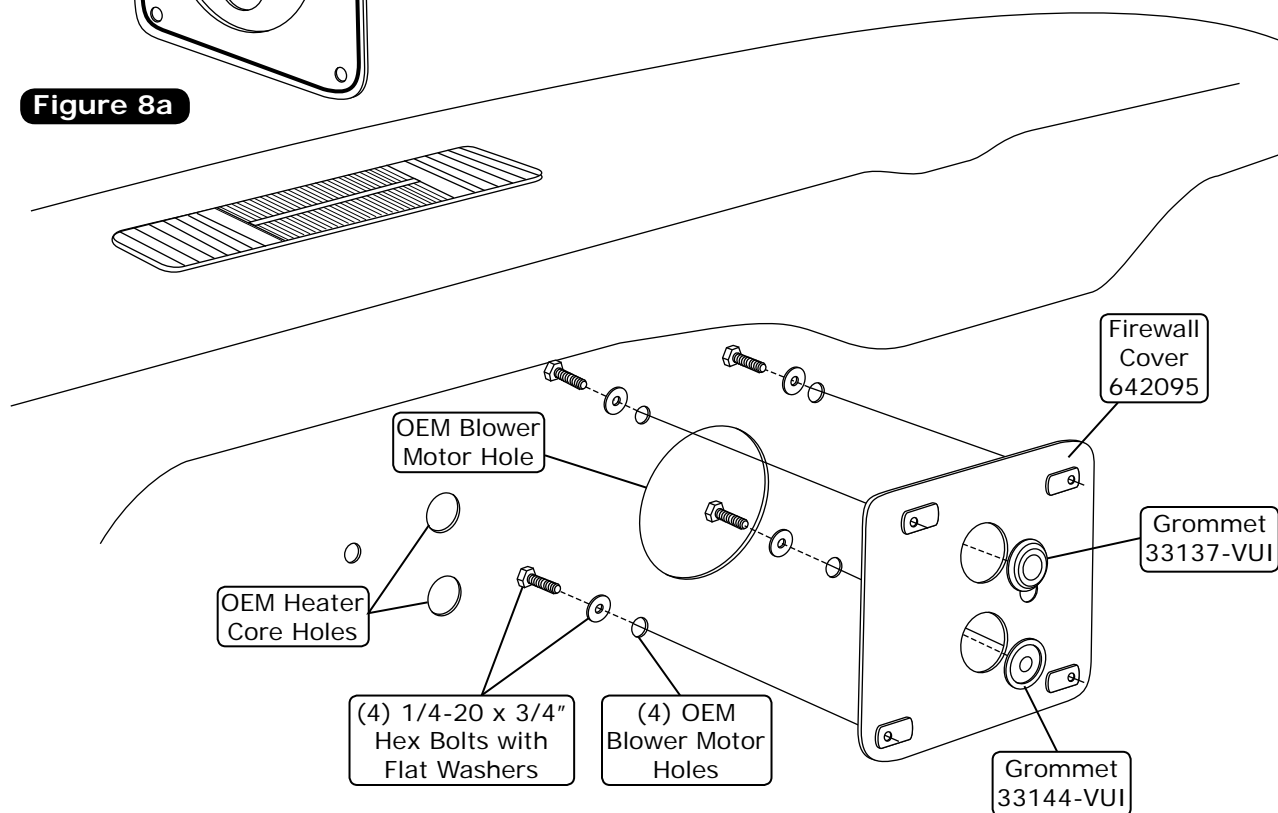

Figure 8



www.vintageair.com

Evaporator Installation

NOTE: To ensure a watertight seal between the passenger compartment and the vehicle exterior, for all bolts passing through the firewall, Vintage Air recommends coating the threads with silicone prior to installation. It is also helpful to coat the firewall grommets with silicone or light oil, before installing the evaporator, to allow the A/C hardlines to slip through more easily.

1. Lift the evaporator unit up under the dashboard. Secure loosely to the firewall using (2) 1/4-20 nuts with washers (See Figure 9, below). **NOTE:** To ensure proper drainage, it is very important that the evaporator is level, both left-right and fore-aft. Check for level on the flat portions of the case around the drain.
2. Using the front evaporator bracket as a guide, mark and drill (2) 3/16" holes in the cowl (See Figure 9a, below).
3. Using (2) #14 x 3/4" sheet metal screws, secure the front evaporator mounting bracket to the inner cowl (See Figure 9a, below).
4. Verify that the evaporator unit is level and square to the dash; then tighten all mounting bolts. **NOTE:** Tighten the bolt on the firewall first. Then tighten the front mounting bracket.

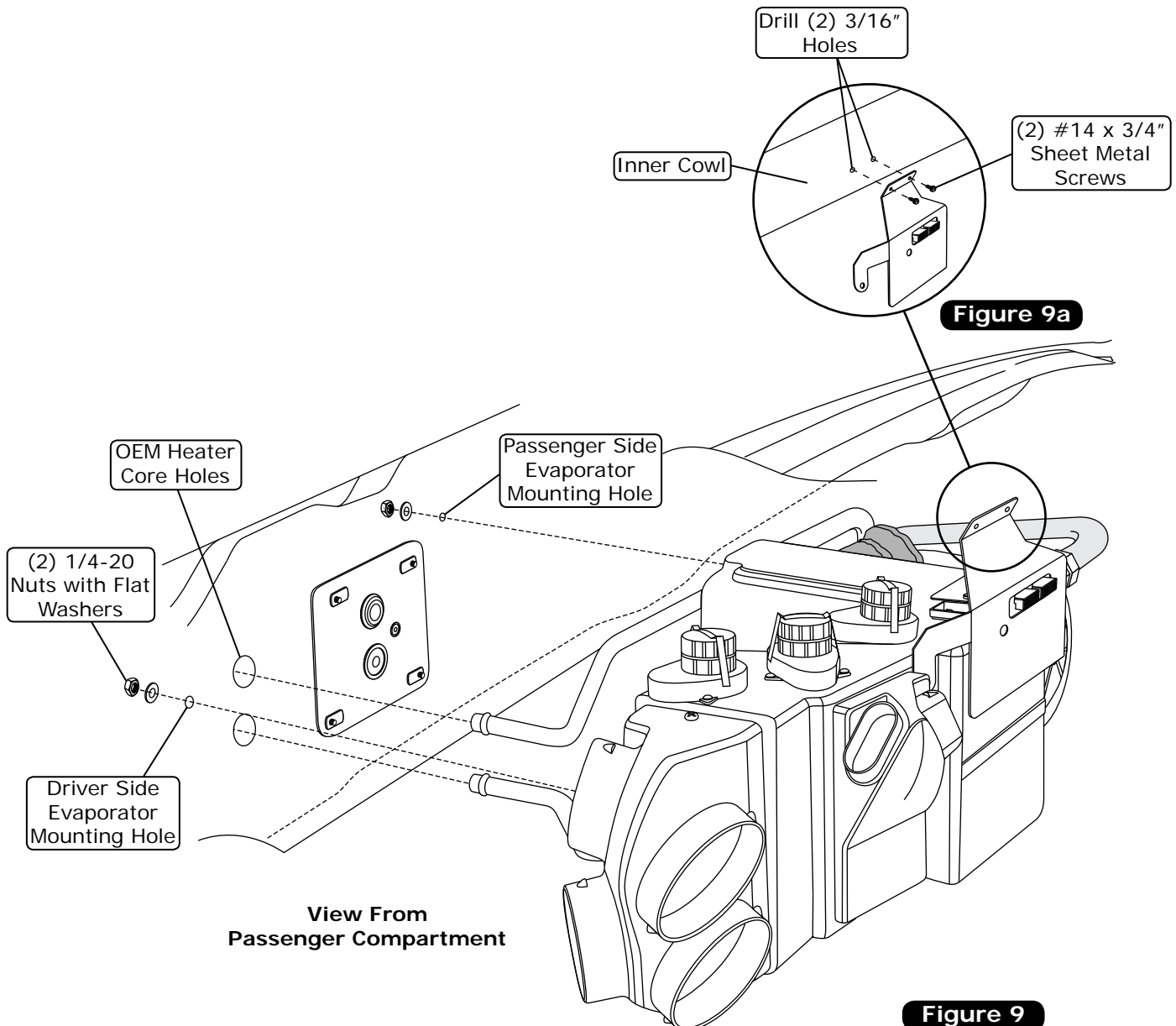



www.vintageair.com

Drain Hose Installation

1. Locate the evaporator drain on the bottom of the evaporator case. In line with the drain, lightly make a mark on the firewall. Measure 1" down and drill a 5/8" hole through the firewall (See Figure 10, below).
2. Attach the drain hose to the outlet on the bottom of the evaporator unit, and route through the firewall.
3. Install a 1/2" drain elbow onto the drain hose (See Figure 10, below).

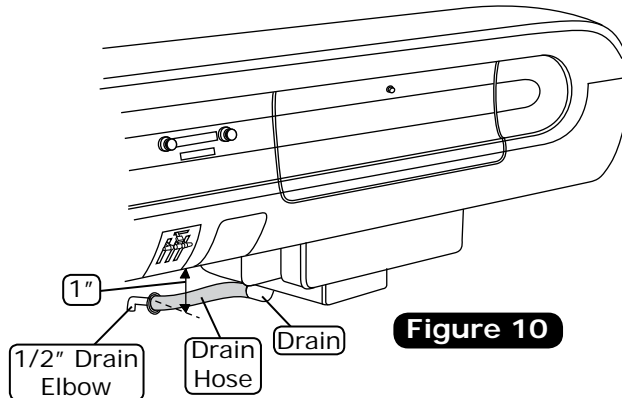
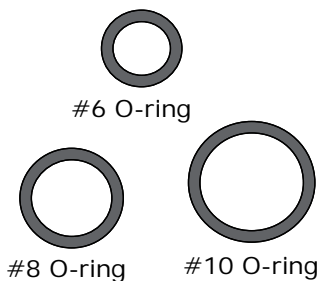
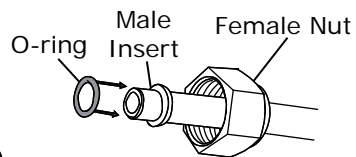

Figure 10

Lubricating O-rings



NOTE: Standard torque specifications:
 #6: 11 to 13 ft-lb.
 #8: 15 to 20 ft-lb.
 #10: 21 to 27 ft-lb.



For a proper seal of fittings: Install supplied O-rings as shown and lubricate with supplied oil.

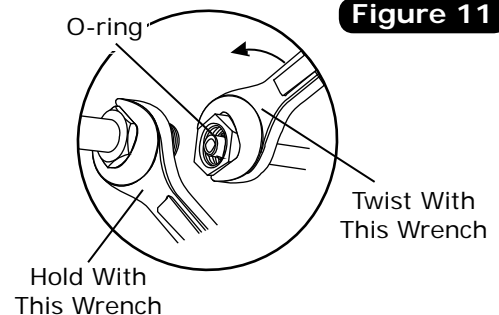
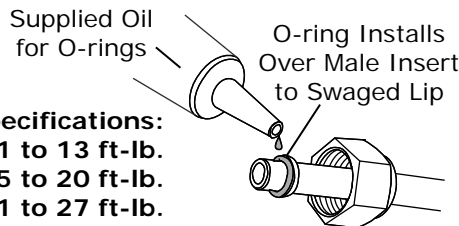

Figure 11

A/C Hose Installation

Standard Hose Kit:

1. Locate the #6 evaporator/drier A/C hose. Lubricate (2) #6 O-rings and connect the 45° female fitting to the drier mounted on the inner fender. The angle is toward the engine (See Photo 3, Page 15). Then route the 90° female fitting to the #6 evaporator hardline coming through the firewall (See Figure 12, Page 14). Route the hose under the fender braces and upper firewall (See Photo 4, Page 15). Tighten each fitting connection as shown in Figure 11, above.
2. Locate the #10 compressor A/C hose. Lubricate (2) #10 O-rings and connect the 90° female fitting with 134a service port to the #10 suction port on the compressor (See Photo 3, Page 15). Then route the 90° female fitting to the #10 evaporator hardline coming through the firewall (See Figure 12, Page 14). Tighten each fitting connection as shown in Figure 11, above. Use (6) tie wraps to secure the #6 and #10 A/C hoses to the fender braces as shown in Photo 4, Page 15.
3. Locate the #8 compressor A/C hose. Lubricate (2) #8 O-rings and connect the 135° female fitting with 134a service port to the #8 discharge port on the compressor. Then route the straight female fitting to the #8 condenser hardline coming through the radiator core support (See Photo 3, Page 15). Tighten each fitting connection as shown in Figure 11, above.

Modified Hose Kit:

1. Refer to separate instructions included with modified hose kit.



www.vintageair.com

Heater Hose & Heater Control Valve Installation

1. Route a piece of heater hose from the water pump to the lower heater hardline on the firewall as shown in Figure 12, below. Push the end of the hose through the hole in the firewall. Secure both ends with hose clamps, and apply a bead of silicone around the heater hose where it passes through the firewall.
2. Route a piece of heater hose from the intake manifold to the upper heater hardline on the firewall as shown in Figure 12, below. Push the end of the hose through the hole in the firewall. Secure both ends with hose clamps.
3. Install the heater control valve into the upper heater hose (pressure side, from intake manifold) as shown in Figure 12, below. Secure using hose clamps. Apply a bead of silicone around the heater hose where it passes through the firewall. **NOTE: Ensure proper flow direction through the valve (the flow direction follows the molded arrow on the valve).**
4. Squeeze the 3/8" wiring grommet into an oval, and feed the heater control valve wiring connector through it. Install the grommet into the firewall as shown in Figure 12, below.

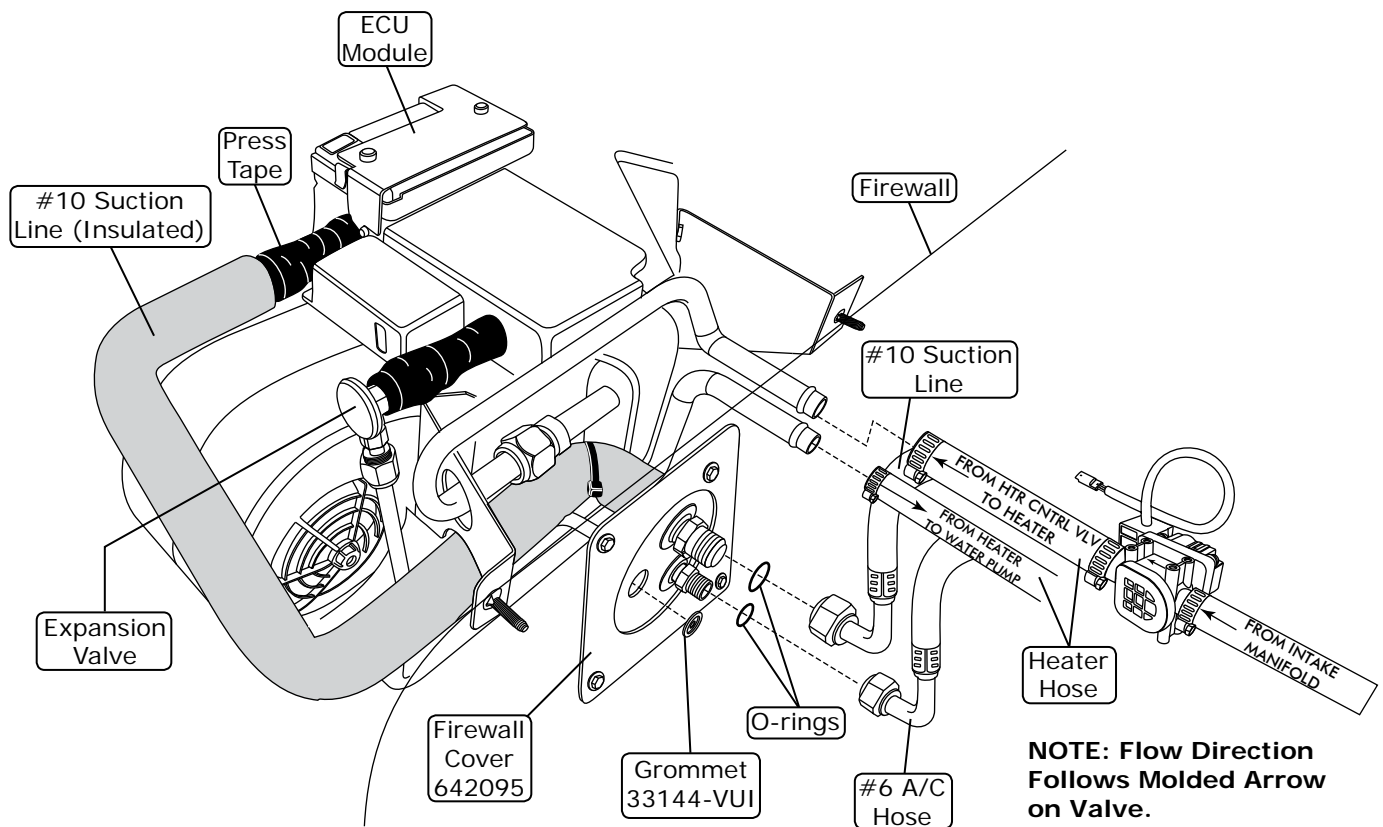

Figure 12



www.vintageair.com

A/C and Heater Hose Routing

NOTE: Vintage Air Systems Require (2) 5/8" Hose Nipples (Not Supplied).

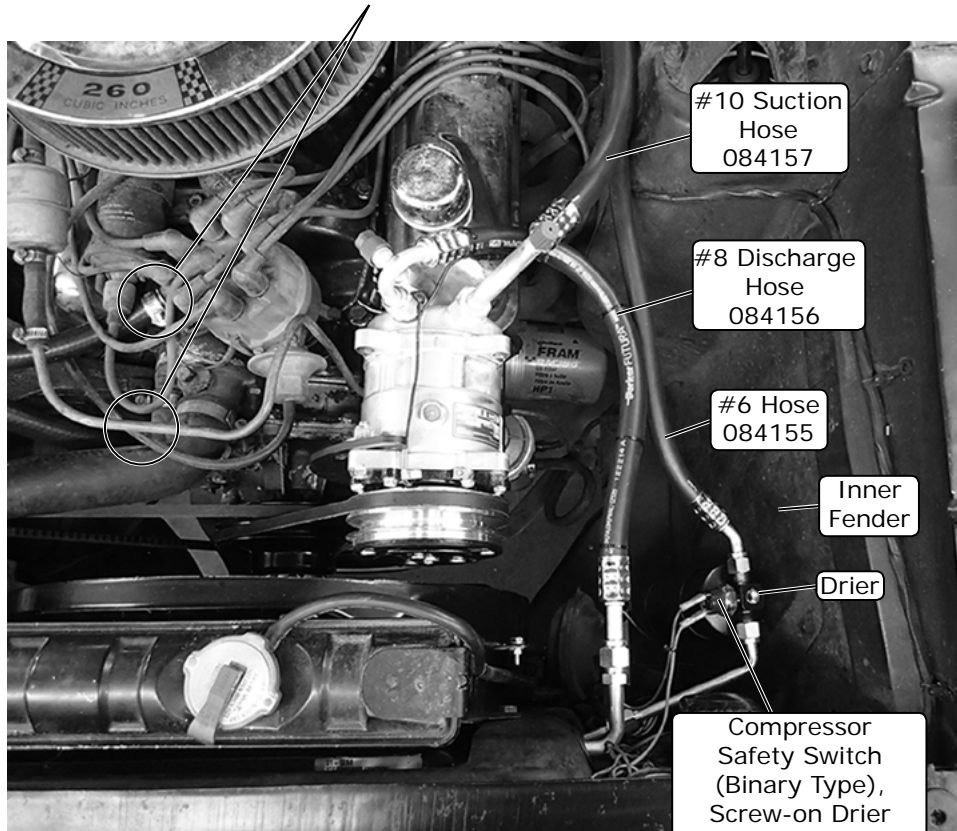

Photo 3

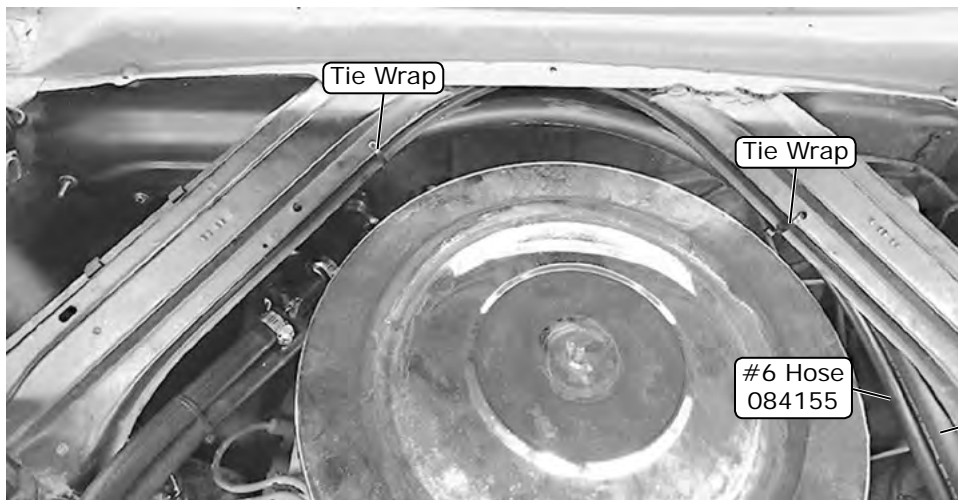

Photo 4



www.vintageair.com

Center Louver Installation

1. Drill (2) 1/8" holes, and install the center louver bezel under the dash using (2) #8 x 1/2" pan head screws as shown in Figure 13, below.
2. Insert the louvers into the center louver bezel as shown in Figure 13, below. **NOTE: It may be helpful to attach the duct hoses to the louvers (See Pages 18 and 19) before inserting the louvers into the bezel.**

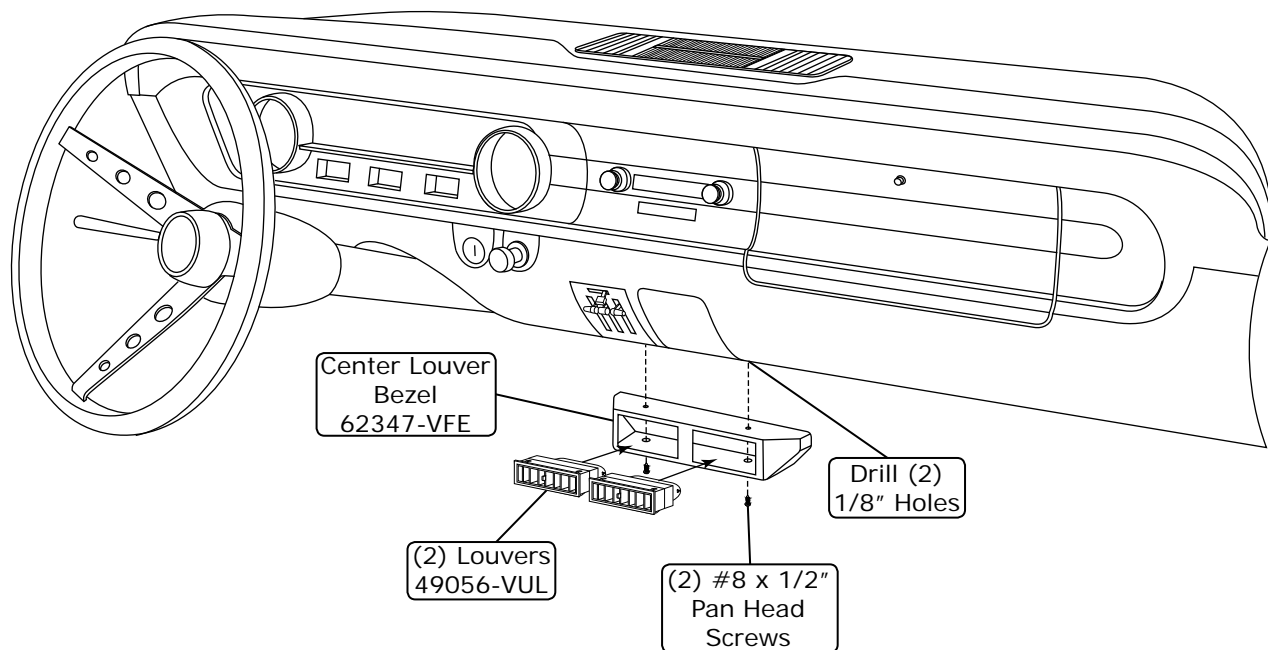

Figure 13



www.vintageair.com

Driver and Passenger Side Under Dash Louver Installation

1. Drill (2) 1/8" holes, and install the driver side louver housing under the dash using (2) #8 x 1/2" pan head screws as shown in Figure 14, below.
2. Drill (2) 1/8" holes, and install the passenger side louver housing under the dash using (2) #8 x 1/2" pan head screws as shown in Figure 14, below.
3. Install the louvers into the driver and passenger side louver housings as shown in Figure 14, below. **NOTE: It may be helpful to attach the duct hoses to the hose adapters (See Pages 18 and 19) before installing the louvers into the housings.**

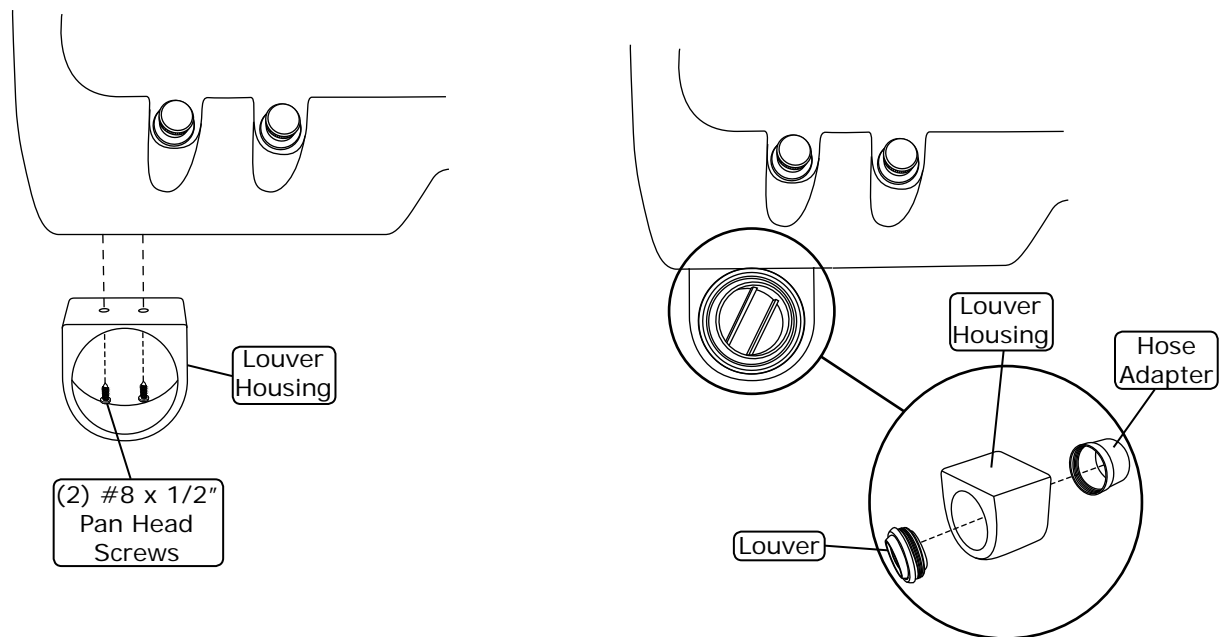
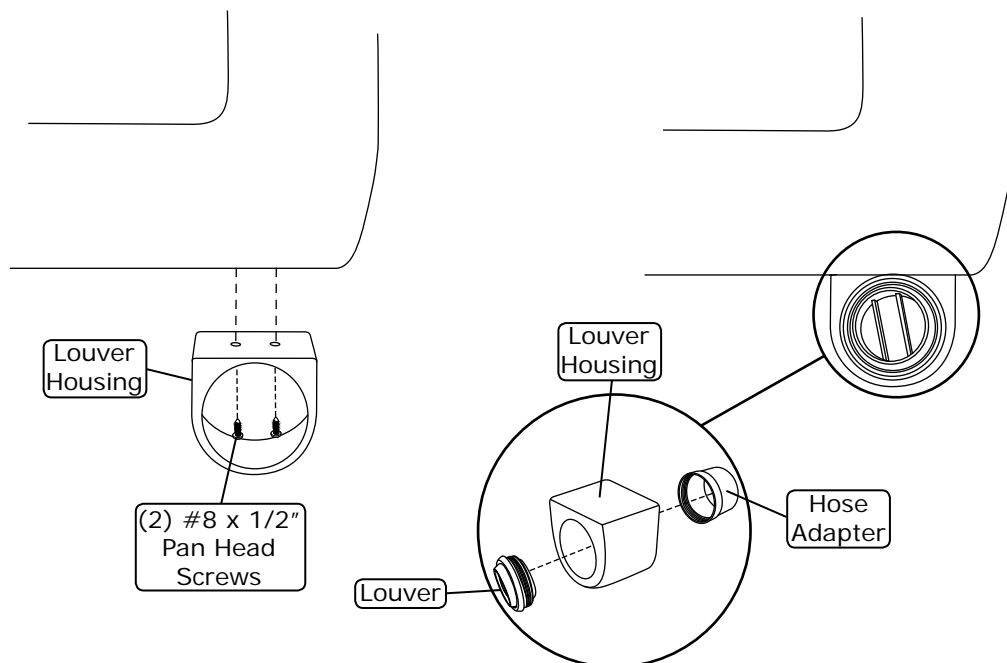

Figure 14





www.vintageair.com

Final Steps

1. Install duct hoses as shown in Figure 17, Page 19. **NOTE: After installing duct hoses, while looking through the glove box opening, turn on the wipers, and check for clearance through the full range of motion.**
2. Route A/C wires (12 volt/grounds/binary switch/heater valve) through 3/8" grommet as shown in Figure 15, below.
3. Install control panel assembly. Refer to control panel instructions.
4. Plug the wiring harnesses into the ECU module on the sub case. Wire according to wiring diagrams on Pages 20 & 21.
5. Install (4) #8 U-nuts onto new glove box (See Figure 16, below).
6. Lay the glove box with the opening face down, and insert it to the right. After it's in, roll the open end to face outward, and pull the glove box into position. Secure using (4) #8 x 1/2" pan head screws (See Figure 16a, below).
7. Reinstall glove box door and glove box door strap (See Figure 16a, below).
8. Reinstall all previously removed items.
9. Fill radiator with at least a 50/50 mixture of approved antifreeze and distilled water. It is the owner's responsibility to keep the freeze protection at the proper level for the climate in which the vehicle is operated. Failure to follow antifreeze recommendations will cause heater core to corrode prematurely and possibly burst in A/C mode and/or freezing weather, voiding your warranty.
10. Double check all fittings, brackets and belts for tightness.
11. Vintage Air recommends that all A/C systems be serviced by a licensed automotive A/C technician.
12. Evacuate the system for a minimum of 45 minutes prior to charging, and perform a leak check prior to servicing.
13. Charge the system to the capacities stated on Page 4 of this instruction manual.
14. See Operation of Controls procedures on Page 22.

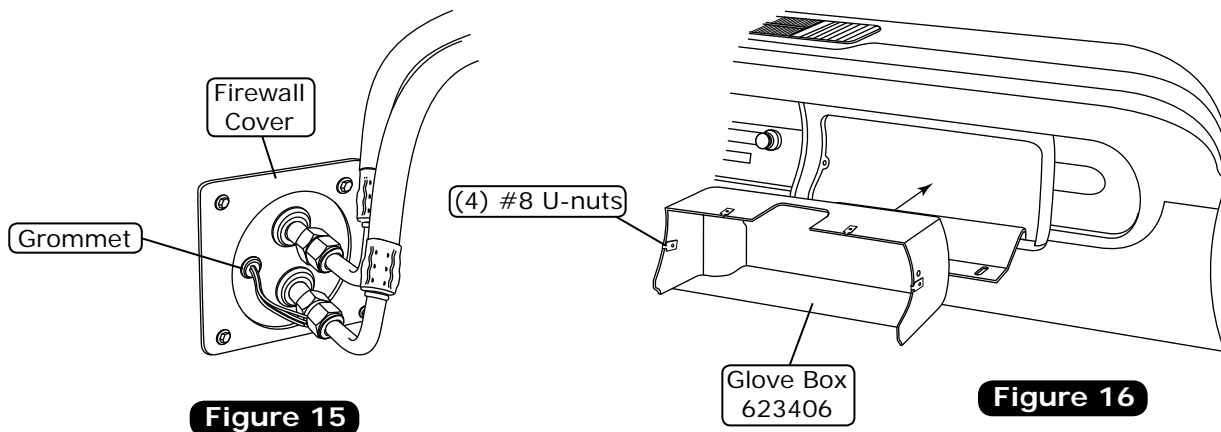

Figure 15

Figure 16

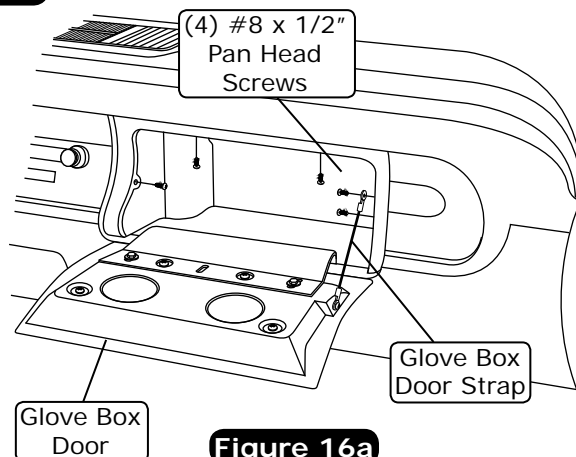
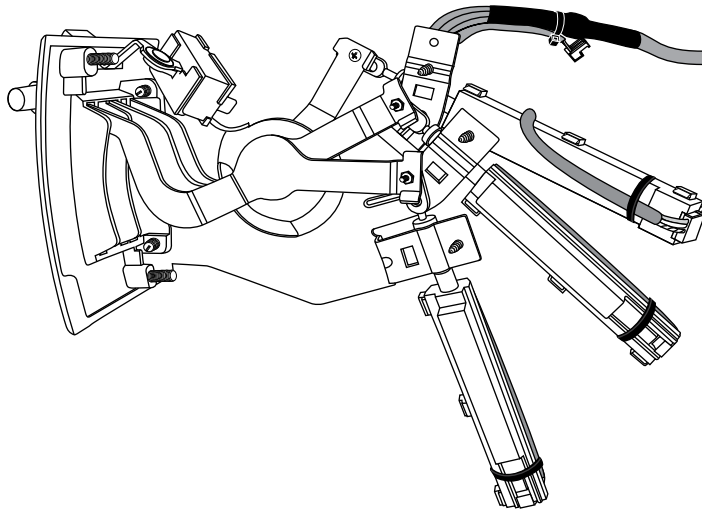

Figure 16a



www.vintageair.com

Control Panel & Duct Hose Routing



NOTE: While looking through the glove box opening, turn on the wipers, and check for clearance through the full range of motion.

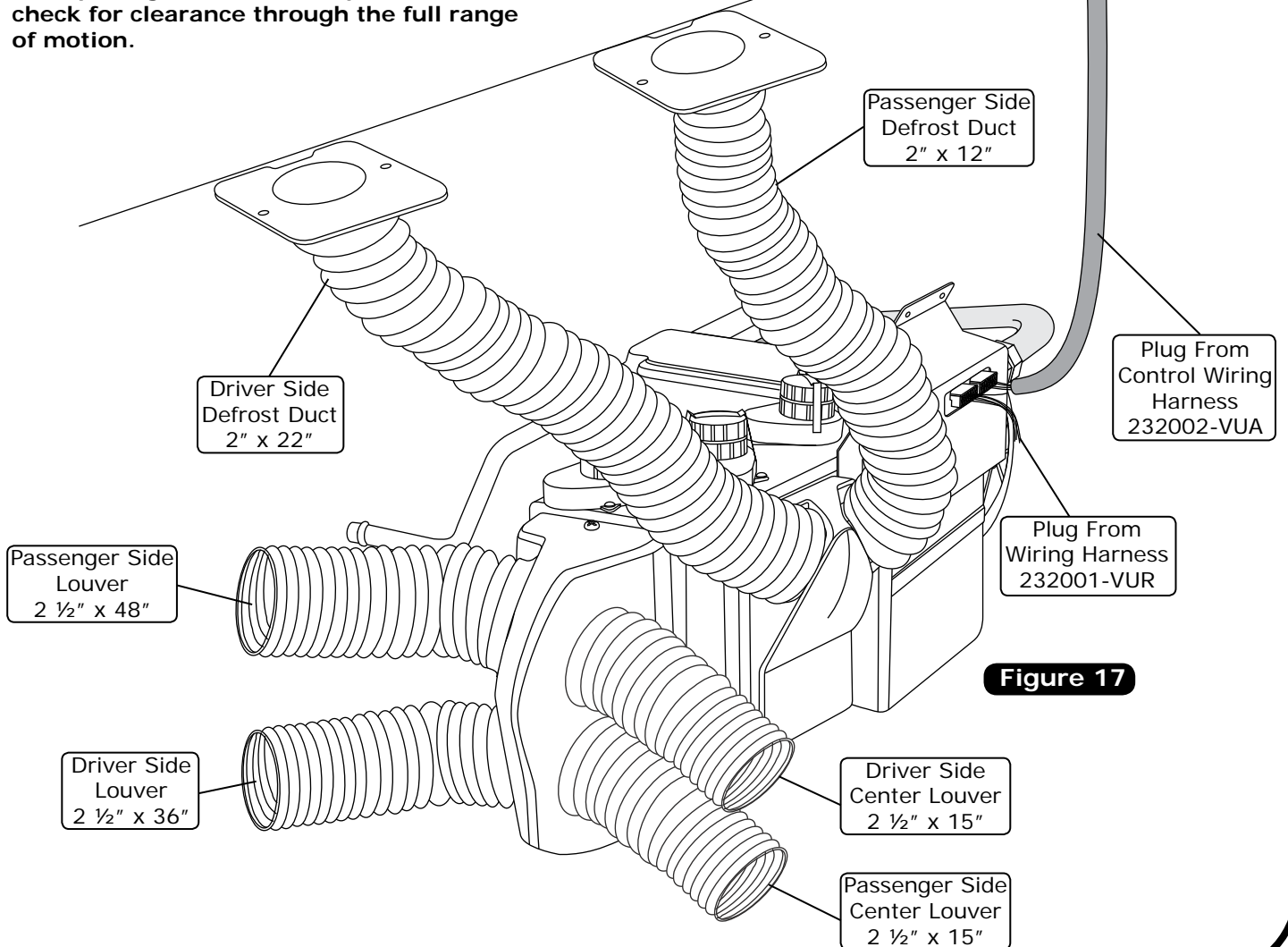

Figure 17



www.vintageair.com

Wiring Diagram

232007-VUR

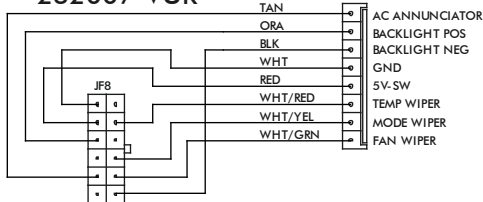

VIEWED FROM WIRE SIDE

232002-VUA

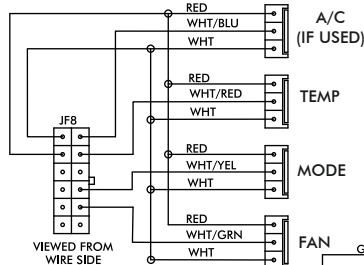

VIEWED FROM WIRE SIDE

PROGRAM

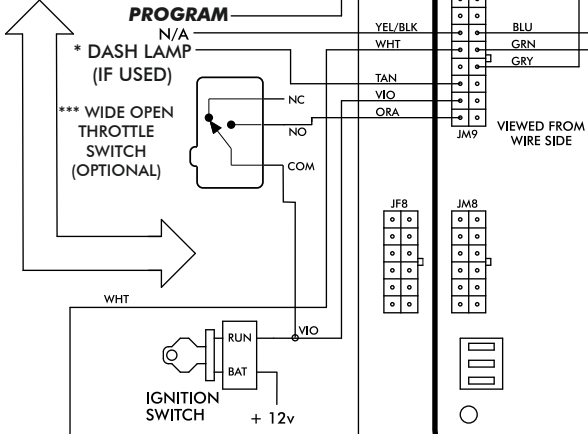

GEN IV ECU

GEN IV WIRING DIAGRAM
REV E, 10/6/2017

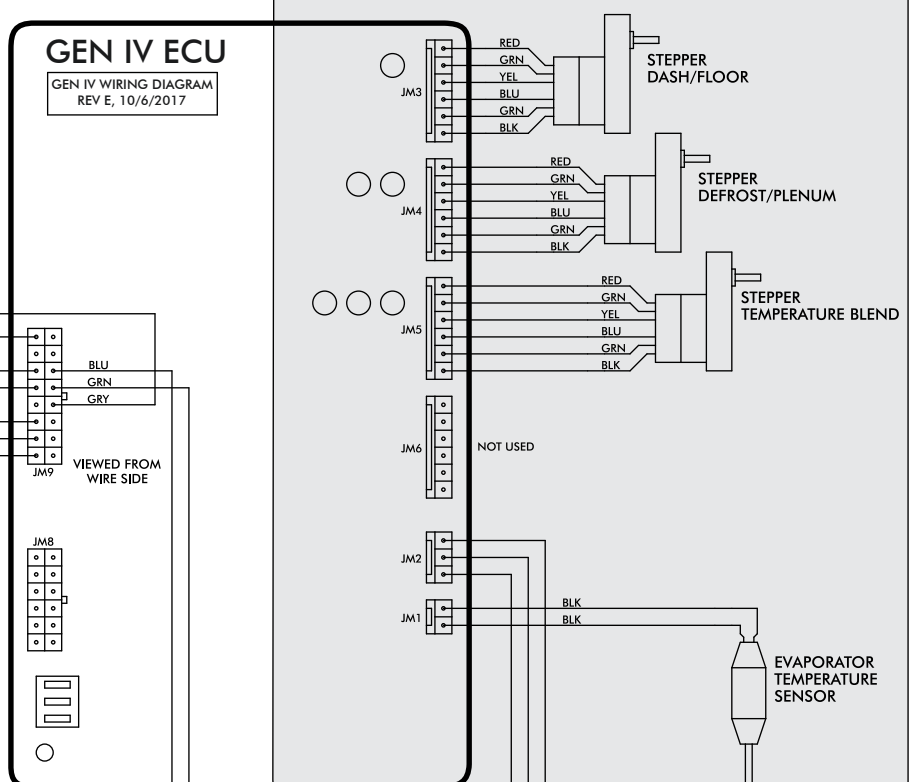

PRE-WIRED

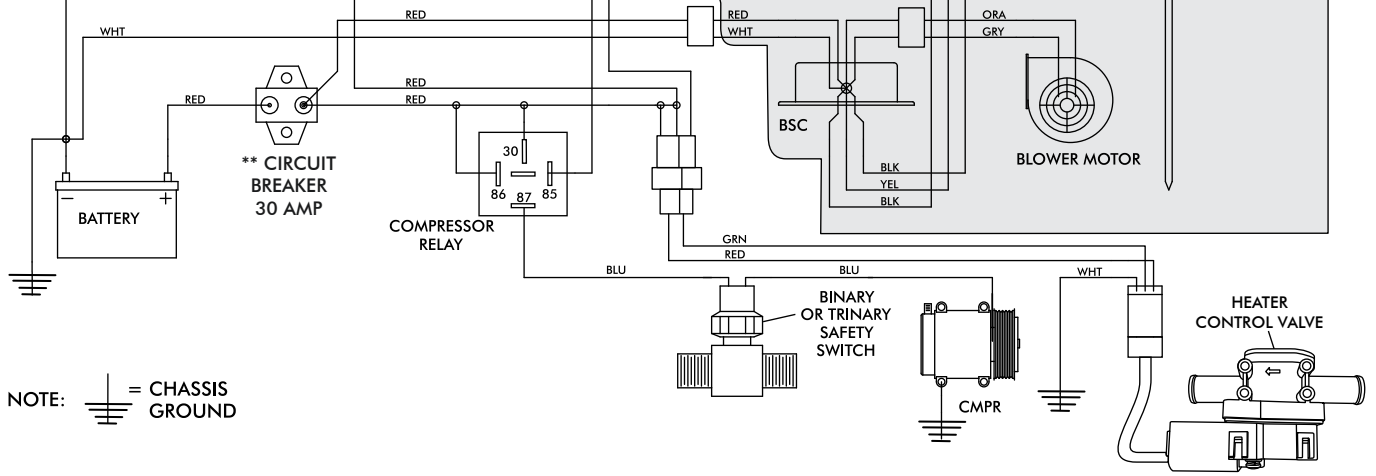

NOTE: = CHASSIS GROUND

- * Dash lamp is used only with type 232007-VUR harness.
- ** Warning: Always mount circuit breaker as close to the battery as possible. (NOTE: Wire between battery and circuit breaker is unprotected and should be carefully routed to avoid a short circuit).
- *** Wide open throttle switch contacts close only at full throttle, which disables A/C



www.vintageair.com

Gen IV Wiring Connection Instruction

WIRING HARNESS

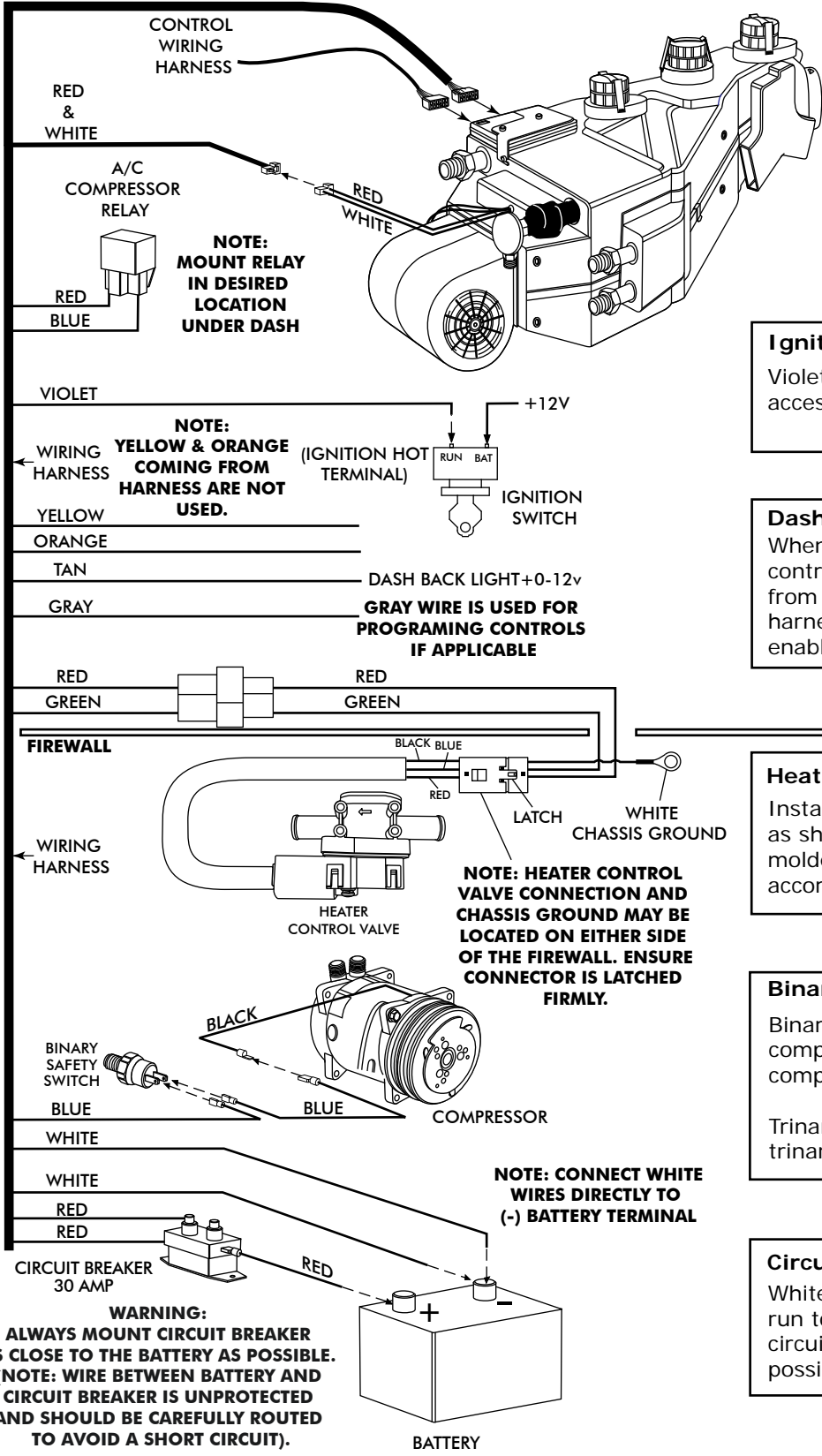

RED & WHITE

A/C COMPRESSOR RELAY

RED BLUE

NOTE: MOUNT RELAY IN DESIRED LOCATION UNDER DASH

VIOLET

WIRING HARNESS

NOTE: YELLOW & ORANGE COMING FROM HARNESS ARE NOT USED.

(IGNITION HOT TERMINAL)

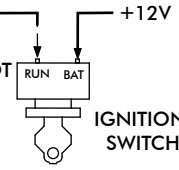

+12V

IGNITION SWITCH

YELLOW ORANGE TAN GRAY

DASH BACK LIGHT +0-12v

GRAY WIRE IS USED FOR PROGRAMMING CONTROLS IF APPLICABLE

RED GREEN

RED GREEN

FIREWALL

WIRING HARNESS

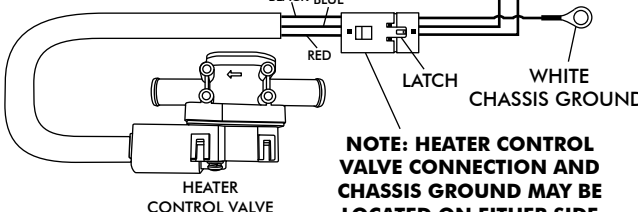

BLACK BLUE

RED

LATCH

WHITE CHASSIS GROUND

HEATER CONTROL VALVE

NOTE: HEATER CONTROL VALVE CONNECTION AND CHASSIS GROUND MAY BE LOCATED ON EITHER SIDE OF THE FIREWALL. ENSURE CONNECTOR IS LATCHED FIRMLY.

BINARY SAFETY SWITCH

BLUE WHITE

BLACK

BLUE

COMPRESSOR

WHITE RED RED

NOTE: CONNECT WHITE WIRES DIRECTLY TO (-) BATTERY TERMINAL

CIRCUIT BREAKER 30 AMP

RED

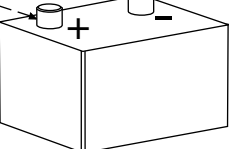

BATTERY

WARNING: ALWAYS MOUNT CIRCUIT BREAKER AS CLOSE TO THE BATTERY AS POSSIBLE. (NOTE: WIRE BETWEEN BATTERY AND CIRCUIT BREAKER IS UNPROTECTED AND SHOULD BE CAREFULLY ROUTED TO AVOID A SHORT CIRCUIT).

Ignition Switch:
Violet 12V ignition switch source (key on accessory) position must be switched.

Dash Light:
When using a Vintage Air-supplied control panel, connect the tan wire from the Gen IV evaporator wiring harness to the factory dash lights to enable panel backlighting.

Heater Control Valve:
Install with servo motor facing down, as shown. Note flow direction arrow molded into valve body and install accordingly.

Binary/Trinary & Compressor:
Binary: Connect as shown (typical compressor wiring). Be sure compressor body is grounded.
Trinary Switch: Connect according to trinary switch wiring diagram.

Circuit Breaker/Battery:
White **must** run to (-) battery. Red may run to (+) battery or starter. Mount circuit breaker as close to battery as possible.



www.vintageair.com

Operation of Controls

On Gen IV systems with three lever/knob controls, the temperature control toggles between heat and A/C operations. To activate A/C, move the temperature lever/knob all the way to cold and then back it off to the desired vent temperature. For heat operation, move the temperature lever/knob all the way to hot and then adjust to the desired vent temperature. The blower will momentarily change speed, each time you toggle between operations, to indicate the change. **NOTE: For proper control panel function, refer to control panel instructions for calibration procedure.**

Blower Speed

This lever/knob controls blower speed, from OFF to HI.

Mode Control

This lever/knob controls the mode positions, from DASH to FLOOR to DEFROST, with a blend in between.

Temperature Control

This lever/knob controls the temperature, from HOT to COLD.

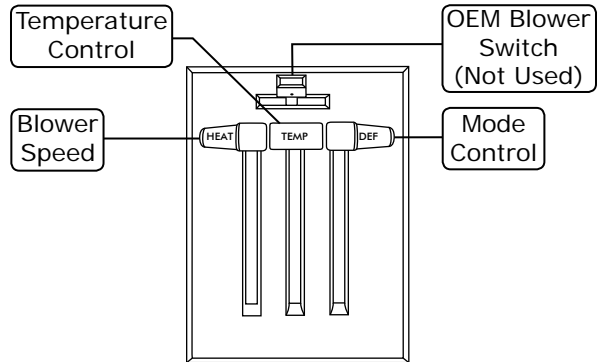

A/C Operation

Blower Speed

Adjust to desired speed.

Mode Control

Adjust to desired mode position (DASH position recommended).

Temperature Control

For A/C operation, adjust to coldest position to engage compressor (Adjust between HOT and COLD to reach desired temperature).

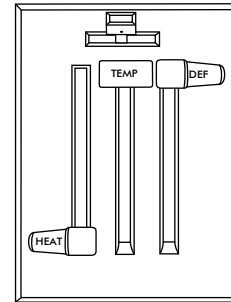

Heat Operation

Blower Speed

Adjust to desired speed.

Mode Control

Adjust to desired mode position (FLOOR position recommended).

Temperature Control

For maximum heating, adjust to hottest position (Adjust between HOT and COLD to reach desired temperature).

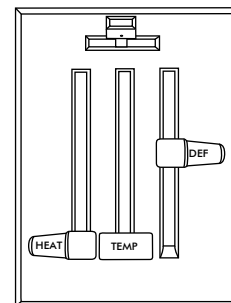

Defrost/De-fog Operation

Blower Speed

Adjust to desired speed.

Temperature Control

Adjust to desired temperature.

Mode Control

Adjust to DEFROST position for maximum defrost, or between FLOOR and DEFROST positions for a bi-level blend (Compressor is automatically engaged).

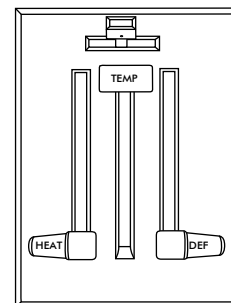



www.vintageair.com

Troubleshooting Guide

Symptom	Condition	Checks	Actions	Notes
1a. Blower stays on high speed when ignition is on.	No other functions work.	Check for damaged pins or wires in control head plug.	Verify that all pins are inserted into plug. Ensure that no pins are bent or damaged in ECU.	Loss of ground on this wire renders control head inoperable.
	All other functions work.	Check for damaged ground wire (white) in control head harness. Check for damaged blower switch or potentiometer and associated wiring.	Verify continuity to chassis ground with white control head wire at various points.	
1b. Blower stays on high speed when ignition is on or off.		Unplug 3-wire BSC control connector from ECU. If blower shuts off, ECU is either improperly wired or damaged.	Be sure the small, 20 GA white ground wire is connected to the battery ground post. If it is, replace the ECU.	See blower switch check procedure.
		Unplug 3-wire BSC control connector from ECU. If blower stays running, BSC is either improperly wired or damaged.	Check to ensure that no BSC wiring is damaged or shorted to vehicle ground. The BSC operates the blower by ground side pulse width modulation switching. The positive wire to the blower will always be hot. If the "ground" side of the blower is shorted to chassis ground, the blower will run on HI.	
2. Compressor will not turn on (All other functions work).	System is not charged.	System must be charged for compressor to engage.	Replace BSC (This will require removal of evaporator from vehicle).	No other part replacements should be necessary.
	System is charged.	Check for faulty A/C potentiometer or associated wiring (not applicable to 3-pot controls). Check for disconnected or faulty thermistor.	Charge system or bypass pressure switch. Check continuity to ground on white control head wire. Check for 5V on red control head wire. Check 2-pin connector at ECU housing.	Danger: Never bypass safety switch with engine running. Serious injury can result. To check for proper pot function, check voltage at white/blue wire. Voltage should be between 0V and 5V, and will vary with pot lever position. Disconnected or faulty thermistor will cause compressor to be disabled.
3. Compressor will not turn off (All other functions work).		Check for faulty A/C potentiometer or associated wiring.	Repair or replace pot/control wiring.	Red wire at A/C pot should have approximately 5V with ignition on. White wire will have continuity to chassis ground. White/Blue wire should vary between 0V and 5V when lever is moved up or down.
		Check for faulty A/C relay.	Replace relay.	



www.vintageair.com

Troubleshooting Guide (Cont.)

Symptom	Condition	Checks	Actions	Notes
4.	Works when engine is not running; shuts off when engine is started (typically early Gen IV, but possible on all versions).	Noise interference from either ignition or alternator.	Install capacitors on ignition coil and alternator. Ensure good ground at all points. Relocate coil and associated wiring away from ECU and ECU wiring. Check for burned or loose plug wires.	Ignition noise (radiated or conducted) will cause the system to shut down due to high voltage spikes. If this is suspected, check with a quality oscilloscope. Spikes greater than 16V will shut down the ECU. Install a radio capacitor at the positive post of the ignition coil (see radio capacitor installation bulletin). A faulty alternator or worn out battery can also result in this condition.
	System will not turn on, or runs intermittently.	Will not turn on under any conditions.	Check for positive power at heater valve green wire and blower red wire. Check for ground on control head white wire.	
		Verify battery voltage is greater than 10 volts and less than 16.	Verify proper meter function by checking the condition of a known good battery.	
5.	No mode change at all.	Check for damaged mode switch or potentiometer and associated wiring.		Typically caused by evaporator housing installed in a bind in the vehicle. Be sure all mounting locations line up and don't have to be forced into position.
	Partial function of mode doors.	Check for obstructed or binding mode doors.		
		Check for damaged stepper motor or wiring.		
6.	Battery voltage is at least 12V.	Check for at least 12V at circuit breaker.	Ensure all system grounds and power connections are clean and tight.	System shuts off blower at 10V. Poor connections or weak battery can cause shutdown at up to 11V.
	Blower turns on and off rapidly.	Battery voltage is less than 12V.	Charge battery.	
7.	Erratic functions of blower, mode, temp, etc.	Check for damaged switch or pot and associated wiring.	Repair or replace.	
8.	When ignition is turned on, blower momentarily comes on, then shuts off. This occurs with the blower switch in the OFF position.	This is an indicator that the system has been reset. Be sure the red power wire is on the battery post, and not on a switched source. Also, if the system is pulled below 7V for even a split second, the system will reset.	Run red power wire directly to battery.	



www.vintageair.com

Passenger Side Evaporator Rear Bracket Template

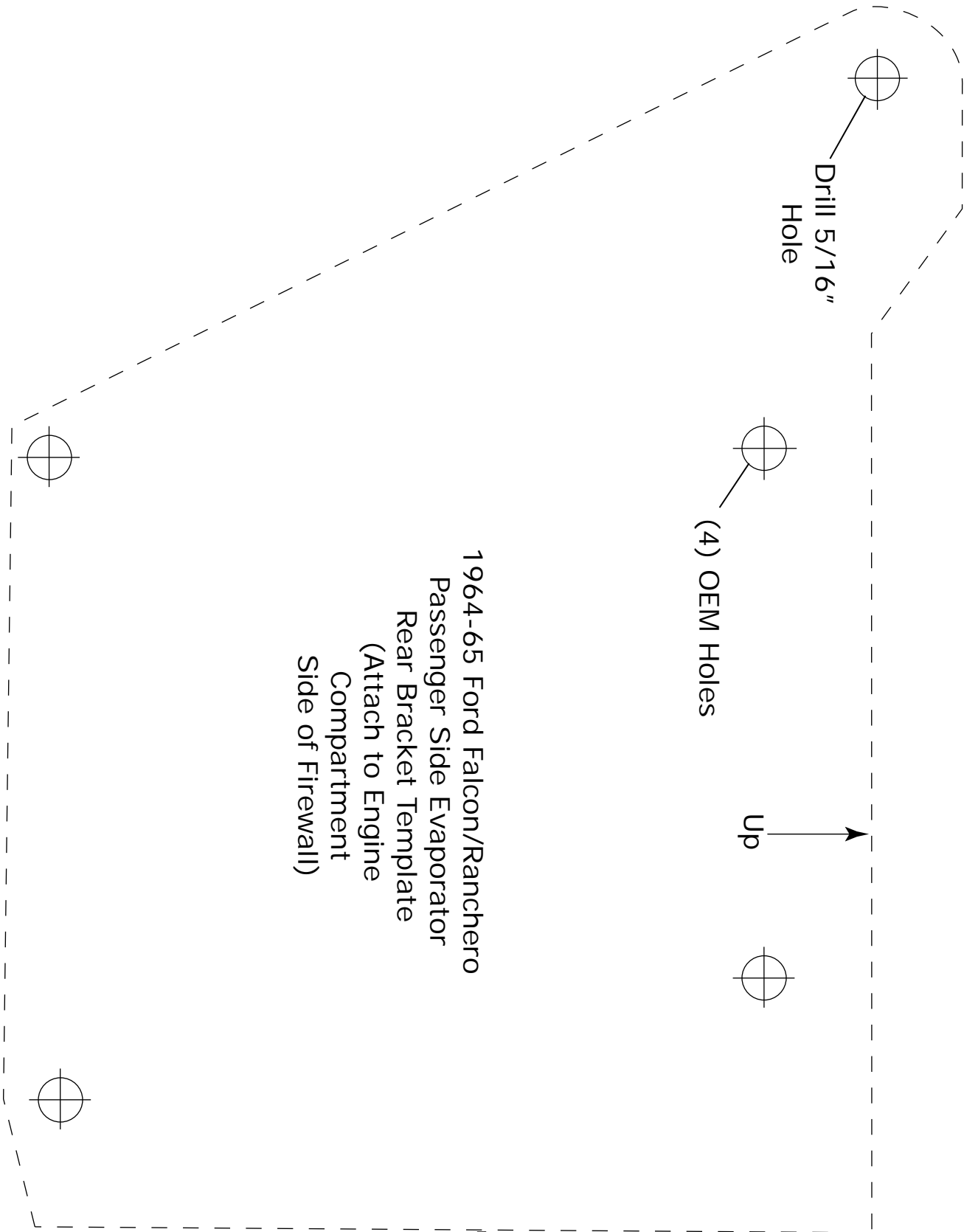

1964-65 Ford Falcon/Ranchero
Passenger Side Evaporator
Rear Bracket Template
(Attach to Engine
Compartment
Side of Firewall)

Cut Along
Dotted Line 



www.vintageair.com

Driver Side Evaporator Rear Bracket Template

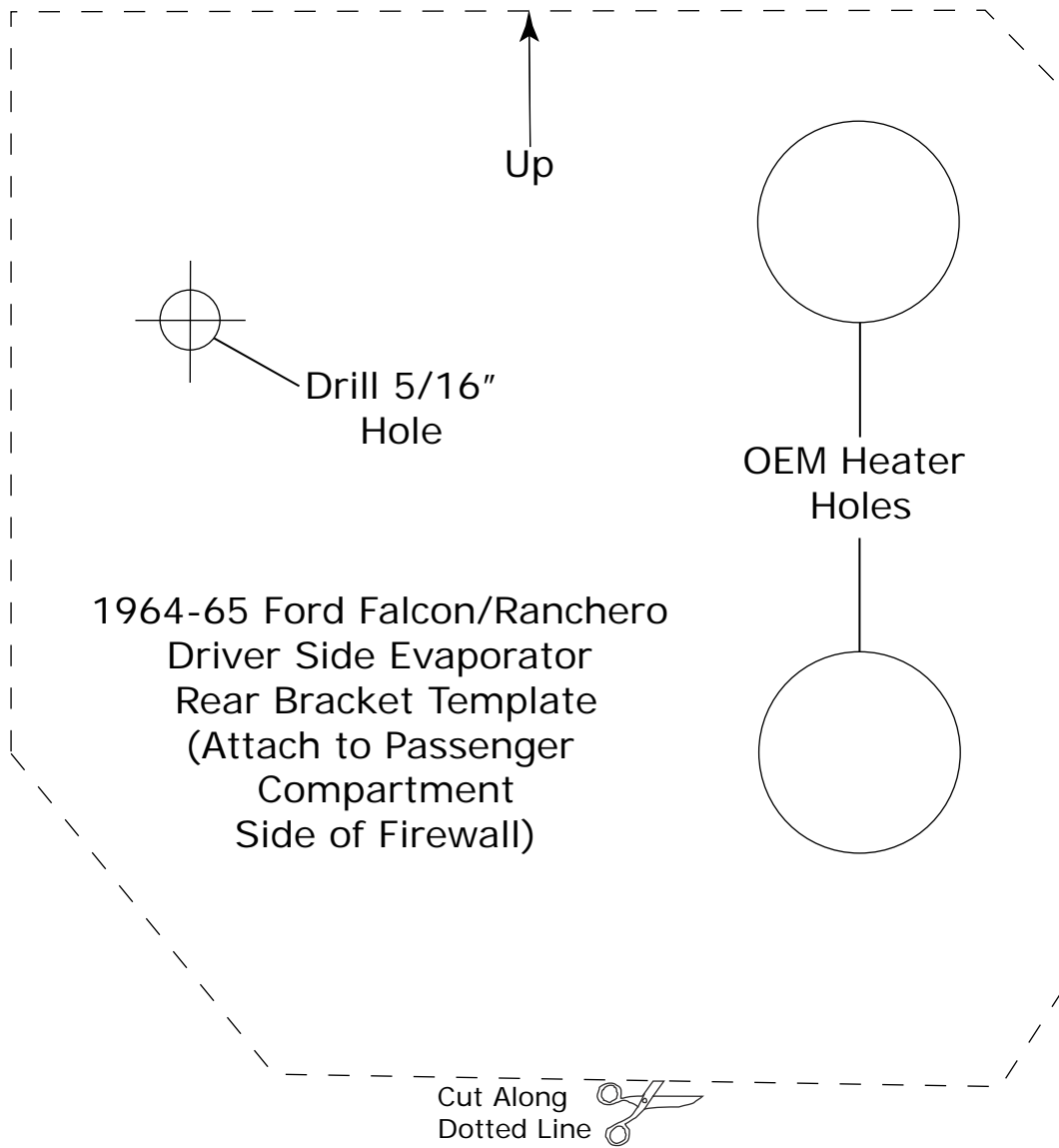



Packing List: Evaporator Kit (554150)

No.	Qty.	Part No.	Description
1.	1	744014	Gen IV Evaporator Sub Case, 45° 4-vent with 204 ECU
2.	1	784150	Accessory Kit

Checked By: _____
 Packed By: _____
 Date: _____

1

Gen IV Evaporator
Sub Case
45° 4-vent with 204 ECU
744014

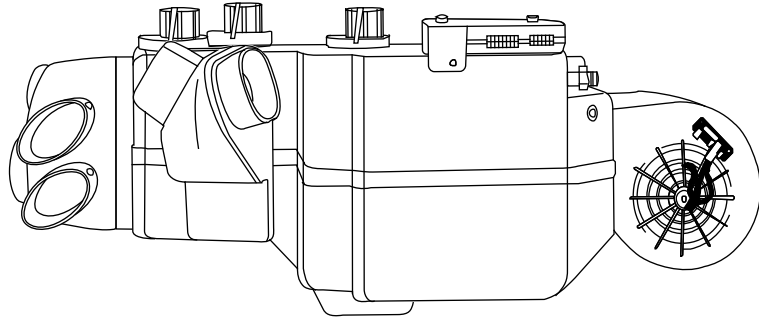

2

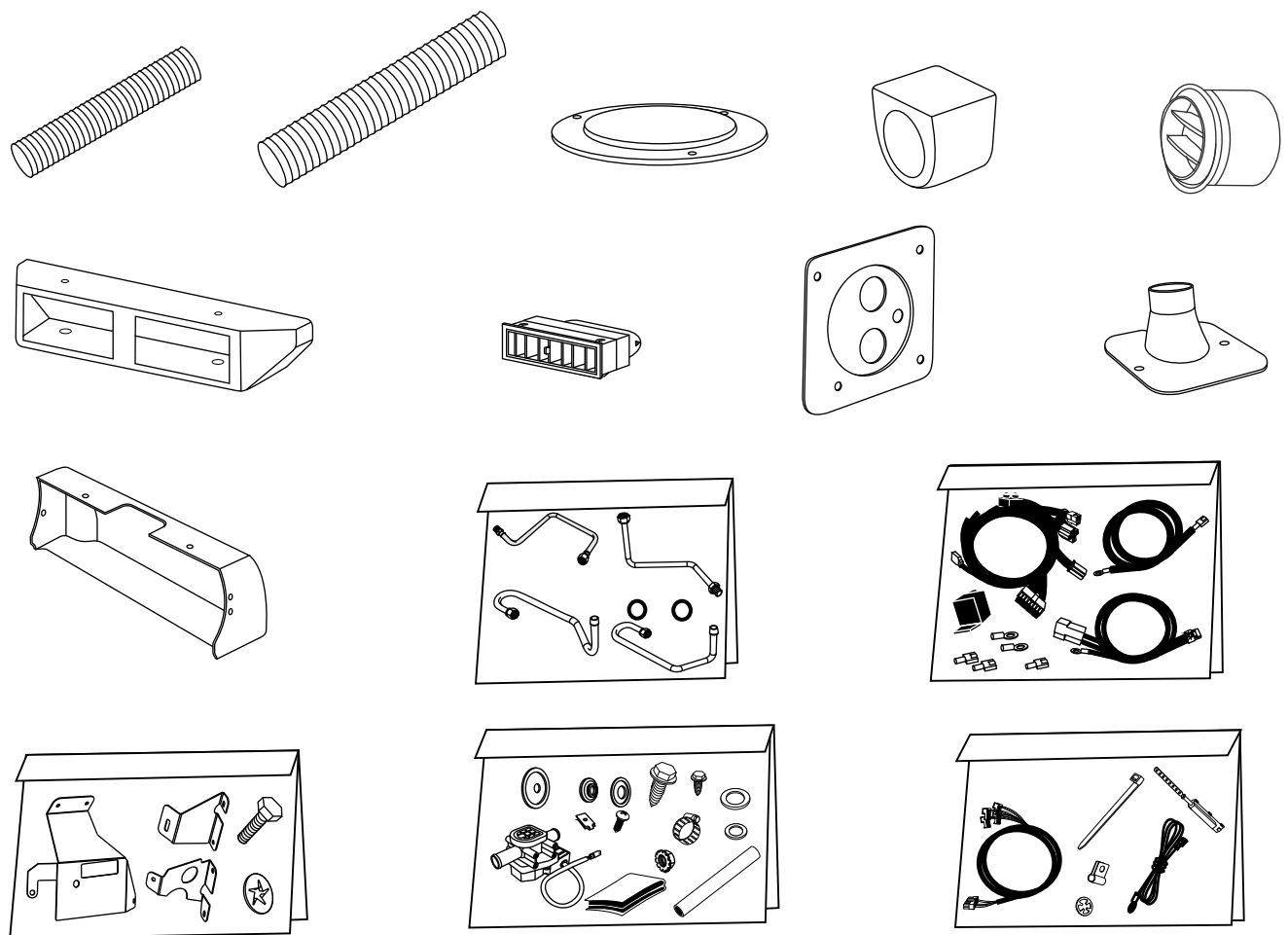

Accessory Kit
784150

**NOTE: Images may not depict actual parts and quantities.
Refer to packing list for actual parts and quantities.**